

TYPES SN5410, SN54H10, SN54L10, SN54LS10, SN54S10, SN7410, SN74H10, SN74LS10, SN74S10 TRIPLE 3-INPUT POSITIVE-NAND GATES

REVISED DECEMBER 1983

- Package Options Include Both Plastic and Ceramic Chip Carriers in Addition to Plastic and Ceramic DIPs
- Dependable Texas Instruments Quality and Reliability

description

These devices contain three independent 3-input NAND gates.

The SN5410, SN54H10, SN54L10, SN54LS10 and SN54S10 are characterized for operation over the full military temperature range of -55°C to 125°C . The SN7410, SN74H10, SN74LS10 and SN74S10 are characterized for operation from 0°C to 70°C .

FUNCTION TABLE (each gate)

INPUTS			OUTPUT
A	B	C	Y
H	H	H	L
L	X	X	H
X	L	X	H
X	X	L	H

logic diagram (each gate)



positive logic

$$Y = \overline{A \cdot B \cdot C} \text{ or } Y = \overline{\overline{A} + \overline{B} + \overline{C}}$$

SN5410, SN54H10, SN54L10 ... J PACKAGE
SN54LS10, SN54S10 ... J OR W PACKAGE
SN7410, SN74H10 ... J OR N PACKAGE
SN74LS10, SN74S10 ... D, J OR N PACKAGE

(TOP VIEW)

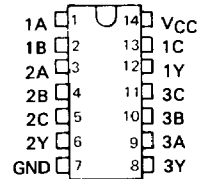

SN5410, SN54H10 ... W PACKAGE

(TOP VIEW)

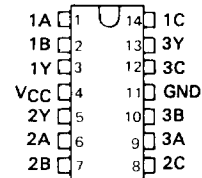

SN54LS10, SN54S10 ... FK PACKAGE
SN74LS10, SN74S10 ... FN PACKAGE

(TOP VIEW)

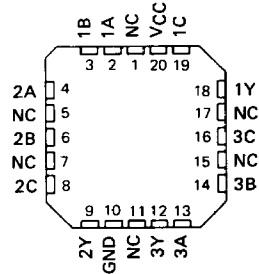

NC - No internal connection

3

TTL DEVICES

PRODUCTION DATA

This document contains information current as of publication date. Products conform to specifications per the terms of Texas Instruments standard warranty. Production processing does not necessarily include testing of all parameters.

TEXAS
INSTRUMENTS

TYPES SN5410, SN54H10, SN54L10, SN54LS10, SN54S10, SN7410, SN74H10, SN74LS10, SN74S10 TRIPLE 3-INPUT POSITIVE-NAND GATES

schematics (each gate)

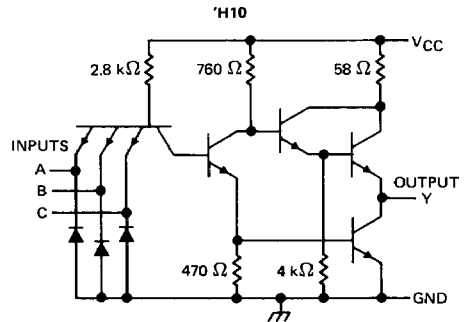
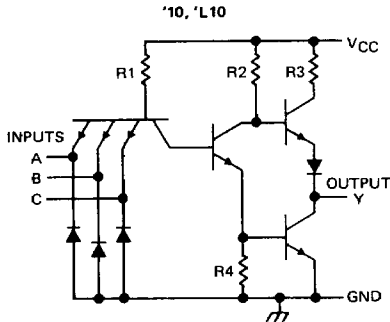

CIRCUIT	R1	R2	R3	R4
'10	4 kΩ	1.6 kΩ	130 Ω	1 kΩ
'L10	40 kΩ	20 kΩ	500 Ω	12 kΩ

Input clamp diodes not on SN54L10 circuit.

3

TTL DEVICES

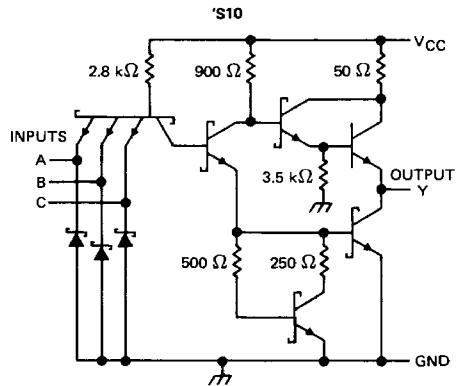
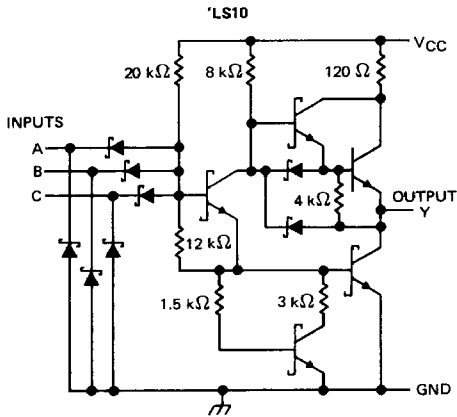

Resistor values shown are nominal.

absolute maximum ratings over operating free-air temperature range (unless otherwise noted)

Supply voltage, V_{CC} (see Note 1) '10, 'H10, 'LS10, 'S10	7 V
'L10	8 V
Input voltage: '10, 'H10, 'L10, 'S10	5.5 V
'LS10	7 V
Operating free-air temperature range: SN54'	-55°C to 125°C
SN74'	0°C to 70°C
Storage temperature range	-65°C to 150°C

NOTE 1: Voltage values are with respect to network ground terminal.

TYPES SN5410, SN7410
TRIPLE 3-INPUT POSITIVE-NAND GATES

recommended operating conditions

	SN5410			SN7410			UNIT
	MIN	NOM	MAX	MIN	NOM	MAX	
V _{CC} Supply voltage	4.5	5	5.5	4.75	5	5.25	V
V _{IH} High-level input voltage	2			2			V
V _{IL} Low-level input voltage	0.8			0.8			V
I _{OH} High-level output current	-0.4			-0.4			mA
I _{OL} Low-level output current	16			16			mA
T _A Operating free-air temperature	-55	125		0	70		°C

electrical characteristics over recommended operating free-air temperature range (unless otherwise noted)

PARAMETER	TEST CONDITIONS †	SN5410			SN7410			UNIT
		MIN	TYP ‡	MAX	MIN	TYP ‡	MAX	
V _{IK}	V _{CC} = MIN, I _I = -12 mA	-1.5			-1.5			V
V _{OH}	V _{CC} = MIN, V _{IL} = 0.8 V, I _{OH} = -0.4 mA	2.4	3.4		2.4	3.4	V	
V _{OL}	V _{CC} = MIN, V _{IH} = 2 V, I _{OL} = 16 mA	0.2 0.4		0.2 0.4			V	
I _I	V _{CC} = MAX, V _I = 5.5 V	1			1			mA
I _{IH}	V _{CC} = MAX, V _I = 2.4 V	40			40			μA
I _{IL}	V _{CC} = MAX, V _I = 0.4 V	-1.6			-1.6			mA
I _{OS} §	V _{CC} = MAX	-20	-55		-18	-55		mA
I _{CCH}	V _{CC} = MAX, V _I = 0 V	3 6		3 6			mA	
I _{CCL}	V _{CC} = MAX, V _I = 4.5 V	9 16.5		9 16.5			mA	

† For conditions shown as MIN or MAX, use the appropriate value specified under recommended operating conditions.

‡ All typical values are at V_{CC} = 5 V, T_A = 25°C.

§ Not more than one output should be shorted at a time.

switching characteristics, V_{CC} = 5 V, T_A = 25°C (see note 2)

PARAMETER	FROM (INPUT)	TO (OUTPUT)	TEST CONDITIONS		MIN	TYP	MAX	UNIT
t _{PLH}	A, B or C	Y	R _L = 400 Ω,	C _L = 15 pF		11	22	ns
t _{PHL}						7	15	ns

NOTE 2: See General Information Section for load circuits and voltage waveforms.

3
TTL DEVICES

TYPES SN54H10, SN74H10 TRIPLE 3-INPUT POSITIVE-NAND GATES

recommended operating conditions

	SN54H10			SN74H10			UNIT
	MIN	NOM	MAX	MIN	NOM	MAX	
V _{CC} Supply voltage	4.5	5	5.5	4.75	5	5.25	V
V _{IH} High-level input voltage	2			2			V
V _{IL} Low-level input voltage			0.8			0.8	V
I _{OH} High-level output current			-0.5			-0.5	mA
I _{OL} Low-level output current			20			20	mA
T _A Operating free-air temperature	-55		125	0		70	°C

electrical characteristics over recommended operating free-air temperature range (unless otherwise noted)

PARAMETER	TEST CONDITIONS †	MIN	TYP ‡	MAX	UNIT
V _{IK}	V _{CC} = MIN, I _I = -8 mA			-1.5	V
V _{OH}	V _{CC} = MIN, V _{IL} = 0.8 V, I _{OH} = -0.5 mA	2.4	3.5		V
V _{OL}	V _{CC} = MIN, V _{IH} = 2 V, I _{OL} = 20 mA		0.2	0.4	V
I _I	V _{CC} = MAX, V _I = 5.5 V			1	mA
I _{IH}	V _{CC} = MAX, V _I = 2.4 V			50	μA
I _{IL}	V _{CC} = MAX, V _I = 0.4 V			-2	mA
I _{OS} §	V _{CC} = MAX	-40		-100	mA
I _{CCH}	V _{CC} = MAX, V _I = 0 V		7.5	12.6	mA
I _{CCL}	V _{CC} = MAX, V _I = 4.5 V		19.5	30	mA

† For conditions shown as MIN or MAX, use the appropriate value specified under recommended operating conditions.

‡ All typical values are at V_{CC} = 5 V, T_A = 25°C.

§ Not more than one output should be shorted at a time, and the duration of the short circuit should not exceed one second.

switching characteristics, V_{CC} = 5 V, T_A = 25°C (see note 2)

PARAMETER	FROM (INPUT)	TO (OUTPUT)	TEST CONDITIONS	MIN	TYP	MAX	UNIT
t _{PLH}	A, B or C	Y	R _L = 280 Ω, C _L = 25 pF		5.9	10	ns
t _{PHL}					6.3	10	ns

NOTE 2: See General Information Section for load circuits and voltage waveforms.

3

TTL DEVICES

TYPE SN54L10 TRIPLE 3-INPUT POSITIVE-NAND GATES

recommended operating conditions

	SN54L10			UNIT
	MIN	NOM	MAX	
V _{CC} Supply voltage	4.5	5	5.5	V
V _{IH} High-level input voltage	2			V
V _{IL} Low-level input voltage			0.7	V
I _{OH} High-level output current			-0.1	mA
I _{OL} Low-level output current			2	mA
T _A Operating free-air temperature	-55		125	°C

electrical characteristics over recommended operating free-air temperature range (unless otherwise noted)

PARAMETER	TEST CONDITIONS †	SN54L10		UNIT	
		MIN	TYP ‡		MAX
V _{OH}	V _{CC} = MIN, V _{IL} = 0.7 V, I _{OH} = -0.1 mA	2.4	3.3	V	
V _{OL}	V _{CC} = MIN, V _{IH} = 2 V, I _{OL} = 2 mA		0.15	0.3	V
I _I	V _{CC} = MAX, V _I = 5.5 V			0.1	mA
I _{IH}	V _{CC} = MAX, V _I = 2.4 V			10	μA
I _{IL}	V _{CC} = MAX, V _I = 0.3 V			-0.18	mA
I _{OS} §	V _{CC} = MAX	-3		-15	mA
I _{CCH}	V _{CC} = MAX, V _I = 0 V		0.33	0.6	mA
I _{CCL}	V _{CC} = MAX, V _I = 4.5 V		0.87	1.53	mA

† For conditions shown as MIN or MAX, use the appropriate value specified under recommended operating conditions.

‡ All typical values are at V_{CC} = 5 V, T_A = 25°C.

§ Not more than one output should be shorted at a time.

switching characteristics, V_{CC} = 5 V, T_A = 25°C (see note 2)

PARAMETER	FROM (INPUT)	TO (OUTPUT)	TEST CONDITIONS	MIN	TYP	MAX	UNIT
t _{PLH}	A, B or C	Y	R _L = 4 kΩ, C _L = 50 pF		35	60	ns
t _{PHL}					31	60	ns

NOTE 2: See General Information Section for load circuits and voltage waveforms.

3
TTL DEVICES

TYPE SN54LS10, SN74LS10 TRIPLE 3-INPUT POSITIVE-NAND GATES

recommended operating conditions

	SN54LS10			SN74LS10			UNIT
	MIN	NOM	MAX	MIN	NOM	MAX	
V _{CC} Supply voltage	4.5	5	5.5	4.75	5	5.25	V
V _{IH} High-level input voltage	2			2			V
V _{IL} Low-level input voltage			0.7			0.8	V
I _{OH} High-level output current			-0.4			-0.4	mA
I _{OL} Low-level output current			4			8	mA
T _A Operating free-air temperature	-55		125	0		70	°C

electrical characteristics over recommended operating free-air temperature range (unless otherwise noted)

PARAMETER	TEST CONDITIONS †	SN54LS10			SN74LS10			UNIT
		MIN	TYP‡	MAX	MIN	TYP‡	MAX	
V _{IK}	V _{CC} = MIN, I _I = -18 mA			-1.5			-1.5	V
V _{OH}	V _{CC} = MIN, V _{IL} = MAX, I _{OH} = -0.4 mA	2.5	3.4		2.7	3.4		V
V _{OL}	V _{CC} = MIN, V _{IH} = 2 V, I _{OL} = 4 mA		0.25	0.4			0.4	V
	V _{CC} = MIN, V _{IH} = 2 V, I _{OL} = 8 mA				0.25	0.5		
I _I	V _{CC} = MAX, V _I = 7 V			0.1			0.1	μA
I _{IH}	V _{CC} = MAX, V _I = 2.7 V			20			20	μA
I _{IL}	V _{CC} = MAX, V _I = 0.4 V			-0.4			-0.4	mA
I _{OS} §	V _{CC} = MAX	-20		-100	-20		-100	mA
I _{CCH}	V _{CC} = MAX, V _I = 0 V		0.6	1.2		0.6	1.2	mA
I _{CCL}	V _{CC} = MAX, V _I = 4.5 V		1.8	3.3		1.8	3.3	mA

† For conditions shown as MIN or MAX, use the appropriate value specified under recommended operating conditions.

‡ All typical values are at V_{CC} = 5 V, T_A = 25°C.

§ Not more than one output should be shorted at a time, and the duration of the short-circuit should not exceed one second.

switching characteristics, V_{CC} = 5 V, T_A = 25°C (see note 2)

PARAMETER	FROM (INPUT)	TO (OUTPUT)	TEST CONDITIONS		MIN	TYP	MAX	UNIT
t _{PLH}	A, B or C	Y	R _L = 2 kΩ,	C _L = 15 pF		9	15	ns
t _{PHL}						10	15	ns

NOTE 2: See General Information Section for load circuits and voltage waveforms.

3 TTL DEVICES

TYPES SN54S10, SN74S10 TRIPLE 3-INPUT POSITIVE-NAND GATES

recommended operating conditions

	SN54S10			SN74S10			UNIT
	MIN	NOM	MAX	MIN	NOM	MAX	
V _{CC} Supply voltage	4.5	5	5.5	4.75	5	5.25	V
V _{IH} High-level input voltage	2			2			V
V _{IL} Low-level input voltage	0.8			0.8			V
I _{OH} High-level output current	-1			-1			mA
I _{OL} Low-level output current	20			20			mA
T _A Operating free-air temperature	-55			0			70 °C

electrical characteristics over recommended operating free-air temperature range (unless otherwise noted)

PARAMETER	TEST CONDITIONS †	SN54S10		SN74S10		UNIT
		MIN	TYP ‡	MAX	MIN	
V _{IJK}	V _{CC} = MIN, I _I = -18 mA	-1.2		-1.2		V
V _{OH}	V _{CC} = MIN, V _{IL} = 0.8 V, I _{OH} = -1 mA	2.5	3.4	2.7	3.4	V
V _{OL}	V _{CC} = MIN, V _{IH} = 2 V, I _{OL} = 20 mA	0.5		0.5		V
I _I	V _{CC} = MAX, V _I = 5.5 V	1		1		mA
I _{IH}	V _{CC} = MAX, V _I = 2.7 V	50		50		µA
I _{IL}	V _{CC} = MAX, V _I = 0.5 V	-2		-2		mA
I _{OS} §	V _{CC} = MAX	-40	-100	-40	-100	mA
I _{CCH}	V _{CC} = MAX, V _I = 0 V	7.5	12	7.5	12	mA
I _{CCL}	V _{CC} = MAX, V _I = 4.5 V	15	27	15	27	mA

† For conditions shown as MIN or MAX, use the appropriate value specified under recommended operating conditions.

‡ All typical values are at V_{CC} = 5 V, T_A = 25°C.

§ Not more than one output should be shorted at a time, and the duration of the short-circuit should not exceed one second.

switching characteristics, V_{CC} = 5 V, T_A = 25°C (see note 2)

PARAMETER	FROM (INPUT)	TO (OUTPUT)	TEST CONDITIONS		MIN	TYP	MAX	UNIT
t _{PLH}	A, B or C	Y	R _L = 280 Ω,	C _L = 15 pF	3	4.5	ns	
t _{PHL}								3
t _{PLH}			R _L = 280 Ω,	C _L = 50 pF	4.5	ns		
t _{PHL}							5	ns

NOTE 2: See General Information Section for load circuits and voltage waveforms.

3

TTL DEVICES