

743 SERIES

Rectangular Type LED Lamps (2.0x5.0mm)

MAIN FEATURES:

- RECTANGULAR LIGHT EMITTING SURFACE.
- FLAT HIGH STERANCE EMITTING SURFACE.
- MOST SUITABLE FOR BACK-LIGHTING LEGENDS.
- IDEAL AS FLUSH MOUNTED PANEL INDICATORS.
- LONG LIFE-SOLID STATE RELIABILITY.

Package Dimensions:

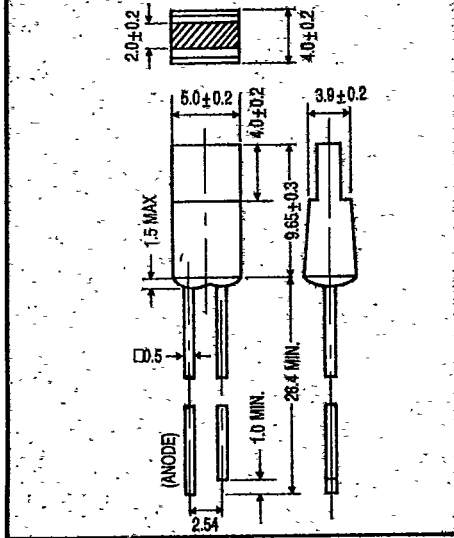

DESCRIPTION:

The 743RD is made with a GaAsP diode emitting red light. The 743HD, 743GD/SGD and 743PYD lamps are made with GaP diodes emitting bright red, green and yellow light respectively. The 743ID, 743YD, 743ED lamps are made with GaAsP on GaP diodes which emit hi-efficiency red, yellow and orange light respectively. All lenses are color-diffused.

ABSOLUTE MAXIMUM RATINGS: (Ta = 25°C)

Reverse Voltage	: 5 Volt
Reverse Current (Vr = 5V)	: 10µA
Operating Temperature Range	: -40°C To 85°C
Storage Temperature Range	: -40°C To 100°C
Lead Soldering Temperature [1.6 mm (1/16 inch) From Body]	: 260°C For 5 Seconds

- NOTE: 1. All dimensions are in millimeters.
2. Lead spacing is measured where the leads emerge from the package.
3. Protruded resin under flange 1.5 mm (0.059") Max.

PART SELECTION AND APPLICATION INFORMATION (RATINGS AT 25°C AMBIENT)

Type No.	Chip		Lens Color	Peak Wave Length λp(nm)	Absolute Maximum Ratings					Electro-Optical Characteristic					Viewing Angle 2θ½ (deg)	Remark
	Material	Emitted Color			Δλ (nm)	Pd (mw)	If(mA)	Peak If(mA)	Vf(V)			Rec If(mA)	Iv(mcd)			
									Min.	Typ.	Max.		Min.	Typ.		
EL743RD	GaAsP	Red	Red Diffused	655	40	110	40	200	1.5	1.7	2.0	10~20	0.2	0.4	150	
EL743HD	GaP	Bright Red	Red Diffused	697	90	45	15	50	1.7	2.1	2.8	5~10	0.3	0.5	150	
EL743ID	GaAsP/GaP	Hi-Eff Red	Red Diffused	635	45	100	30	160	1.7	2.0	2.8	10~20	0.3	1.0	150	
EL743SGD	GaP	Green	Green Diffused	560	30	100	30	160	1.7	2.1	2.8	10~20	0.3	1.0	150	
EL743GD	GaP	Green	Green Diffused	565	30	100	30	160	1.7	2.1	2.8	10~20	0.3	1.0	150	
EL743PYD	GaP	Yellow	Yellow Diffused	570	30	100	30	160	1.7	2.0	2.8	10~20	0.3	1.0	150	
EL743YD	GaAsP/GaP	Yellow	Yellow Diffused	585	35	85	20	160	1.7	2.0	2.8	10~20	0.3	1.0	150	
EL743ED	GaAsP/GaP	Orange	Orange Diffused	635	45	100	30	160	1.7	2.0	2.8	10~20	0.3	1.0	150	

TEST CONDITION FOR EACH PARAMETER:

PARAMETER:	SYMBOL	UNIT	TEST CONDITION
REVERSE VOLTAGE	Vr	VOLT	Vr = 5.0 Volt
REVERSE CURRENT	Ir	µA	If = 20mA
FORWARD VOLTAGE	Vf	VOLT	If = 10mA
LUMINOUS INTENSITY	Iv	MCD	If = 20mA
VIEWING ANGLE	2θ½	DEGREE	
SPECTRAL LINE HALF-WIDTH	Δλ	nm	
POWER DISSIPATION	Pd	mW	
PEAK FORWARD CURRENT (Duty 1/10 @ 1KHz)	If (Peak)	mA	
RECOMMENDED OPERATING CURRENT	If (Rec)	mA	

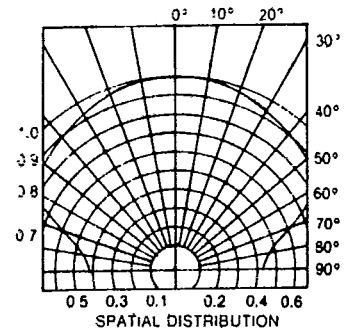

Remark: **The most popular types *Common types The rest are special types
Hi-Eff Red -- High Efficiency Red
Trans -- Transparent