



CRYSTAL OSCILLATOR PROGRAMMABLE

SG-8002 series

- Frequency range : 1 MHz to 125 MHz
- Supply voltage : 3.0 V / 3.3 V / 5.0 V
- Function : Output enable(OE) or Standby(\overline{ST})
- Short mass production lead time by PLL technology.
- SG-Writer available to purchase, please contact Epson Toyocom or local sales representative.



CE, LB, CA

Product Number (please contact us)

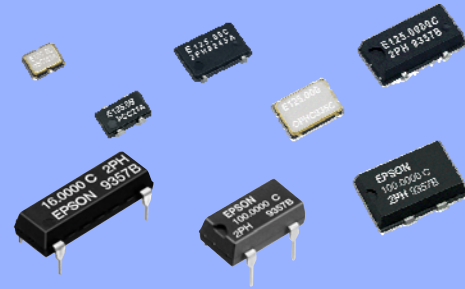

Specifications (characteristics)

Item	Symbol	Specifications *2			Conditions / Remarks
		PT / ST	PH / SH	PC / SC	
Output frequency range	f _o	1 MHz to 125 MHz		—	V _{CC} = 4.5 V to 5.5 V (except SG-8002LB)
		—	1 MHz to 80 MHz	—	V _{CC} = 4.5 V to 5.5 V (SG-8002LB only)
		—	—	1 MHz to 125 MHz	V _{CC} = 3.0 V to 3.6 V
		—	—	1 MHz to 66.7 MHz	V _{CC} = 2.7 V to 3.6 V
Supply voltage	V _{CC}	4.5 V to 5.5 V		2.7 V to 3.6 V	
Storage temperature	T _{stg}	-55 °C to +125 °C (SG-8002CA / JF / JA / DC / DB)			Store as bare product.
		-55 °C to +100 °C (SG-8002JC)			
Operating temperature	T _{use}	-40 °C to +125 °C (SG-8002CE / LB)			*1
		-20 °C to +70 °C / -40 °C to +85 °C			
Frequency tolerance	f _{tol}	B: ±50 × 10 ⁻⁶ , C: ±100 × 10 ⁻⁶			-20 °C to +70 °C
		—	M: ±100 × 10 ⁻⁶	M: ±100 × 10 ⁻⁶	-40 °C to +85 °C (except SG-8002JC) *3
		—	L: ±50 × 10 ⁻⁶	L: ±50 × 10 ⁻⁶	-40 °C to +85 °C (SG-8002LB only) *3
Current consumption	I _{CC}	40 mA Max. (SG-8002CE)		28 mA Max.	No load condition, Max. frequency
		30 mA Max. (SG-8002LB)			
		45 mA Max. (SG-8002CA / JF / JC / JA / DC / DB)			
Output disable current	I _{dis}	30 mA Max.		16 mA Max.	OE=GND (PT,PH,PC) (except SG-8002LB)
		—	25 mA Max.	16 mA Max.	OE=GND (PH,PC) (SG-8002LB only)
Stand-by current	I _{std}	50 µA Max.			\overline{ST} =GND (ST,SH,SC)
Symmetry *1	SYM	40 % to 60 %	—		TTL load: 1.4 V, Max. load condition (except SG-8002LB)
		—	40 % to 60 %		CMOS load: 50 % V _{CC} level, Max. load condition (except SG-8002LB)
		—	40 % to 60 %	—	50 % V _{CC} , L _{CMOS} =15 pF, ≤80 MHz (SG-8002LB)
		—	—	40 % to 60 %	50 % V _{CC} , L _{CMOS} =15 pF, V _{CC} =3.0 V to 3.6 V, ≤125 MHz (SG-8002LB)
		—	—	40 % to 60 %	50 % V _{CC} , L _{CMOS} =15 pF, V _{CC} =2.7 V to 3.6 V, ≤66.7 MHz (SG-8002LB)
High output voltage	V _{OH}	45 % to 55 %			*1
Low output voltage	V _{OL}	V _{CC} -0.4 V Min.			I _{OH} =-16 mA (PT,ST,PH,SH) , -8 mA (PC,SC)
Output load condition (TTL) *1	L _{TTL}	5 TTL Max.	—		I _{OL} =16 mA (PT,ST,PH,SH) , 8 mA (PC,SC)
		5 TTL Max.	—		Max. frequency and Max. Supply voltage (SG-8002CE / CA / JA / DC / DB)
Output load condition (CMOS) *1	L _{CMOS}	15 pF Max.			Max. frequency and Max. Supply voltage (SG-8002JF / JC)
		—	15 pF Max.		Max. frequency and Max. Supply voltage (SG-8002LB)
		15 pF Max.	25 pF Max.	15 pF Max.	Max. frequency and Max. Supply voltage (SG-8002CA / JA / DC / DB)
Output enable / disable input voltage	V _{IH}	2.0 V Min.		70 % V _{CC} Min.	OE terminal or \overline{ST} terminal
	V _{IL}	0.8 V Max.		20 % V _{CC} Max.	
Rise / Fall time *1	tr/ tf	4 ns Max.	—		TTL load: 0.4 V to 2.4 V level (except SG-8002LB)
		—	3 ns Max.		CMOS load: 20 % V _{CC} to 80 % V _{CC} level
Start-up time	t _{str}	10 ms Max.			Time at minimum supply voltage to be 0 s
Frequency aging	f _{aging}	±5 × 10 ⁻⁶ / year Max.			+25 °C, V _{CC} =5.0 V / 3.3 V (PC,SC) First year

*1 Operating temperature, the available frequency, symmetry, output load conditions and rise/fall time, please refer to "Outline specifications" page.

*2 PLL-PLL connection & Jitter specification, please refer to "Jitter specifications and characteristics chart" page.

*3 Refer to "Outline specifications" (Frequency range) for "M" and "L" tolerance availability. Checking possible by the Frequency checking program.

External dimensions and Recommended footprint

(Unit:mm)

SG-8002CE Ceramic SON 4pin 3.2x2.5x1.05 mm

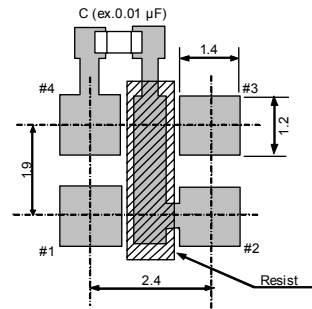
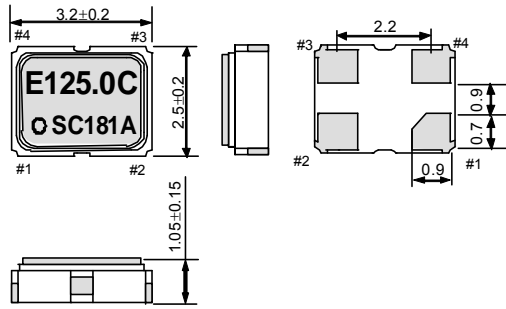

SG-8002LB SOJ 4pin 5.0x3.2x1.2 mm

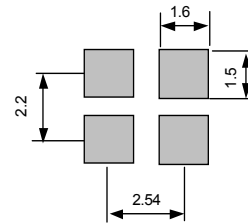
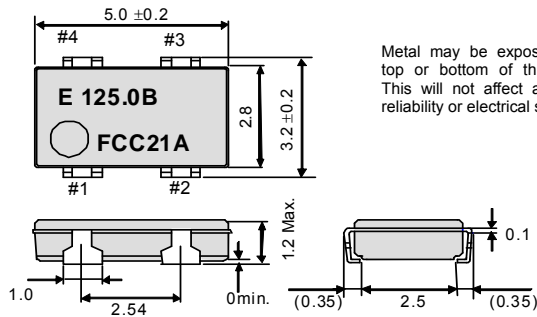

SG-8002CA Ceramic SON 4pin 7.0x5.0x1.4 mm

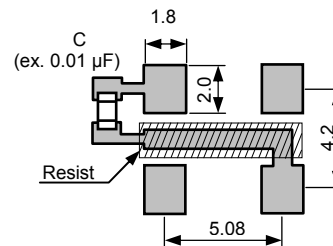
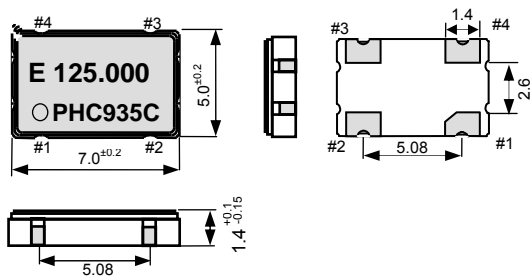

SG-8002JF SOJ 4pin 7.1x5.1x1.5 mm

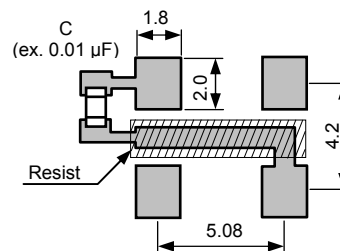
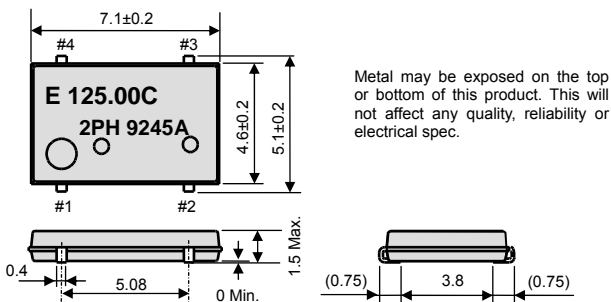

Note.

- OE Pin (PT, PH, PC)
- OE Pin = "H" or "open": Specified frequency output.
- OE Pin = "L": Output is high impedance.

- ST Pin (ST, SH, SC)
- ST Pin = "H" or "open": Specified frequency output.
- ST Pin = "L": Output is low level (weak pull - down), oscillation stops.

Pin map

Pin	Connection
1	OE or \overline{ST}
2	GND
3	OUT
4	VCC

To maintain stable operation, provide a 0.01µF to 0.1µF by-pass capacitor at a location as near as possible to the power source terminal of the crystal product (between Vcc - GND).



External dimensions and Recommended footprint (Continued)

(Unit:mm)

SG-8002JC SOJ 4pin 10.5x5.8x2.7 mm Package and pin compatible with SG-636. 

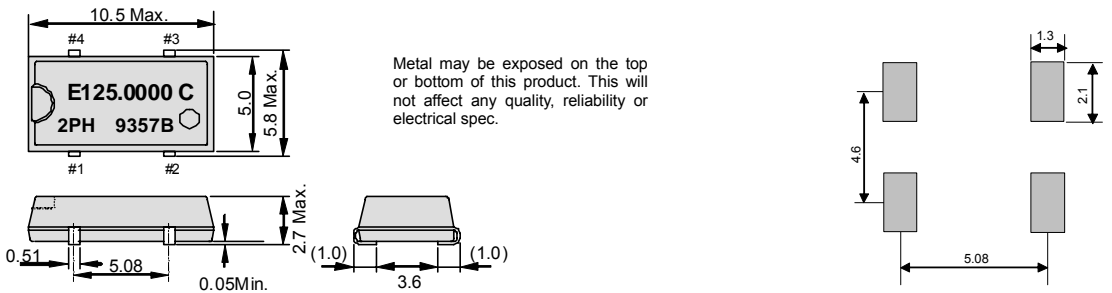

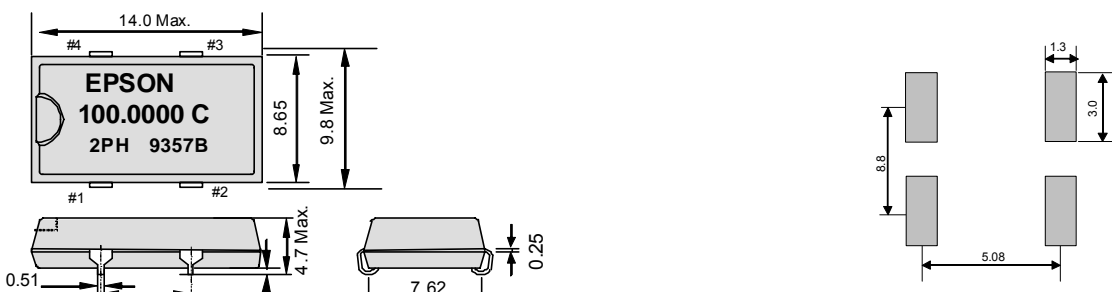

Metal may be exposed on the top or bottom of this product. This will not affect any quality, reliability or electrical spec.

SG-8002JA SOJ 4pin 14.0x9.8x4.7 mm Package and pin compatible with SG-615. 

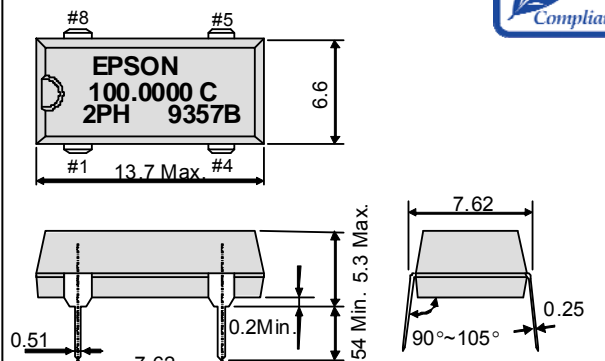

SG-8002DC DIP half size 



SG-8002DB DIP full size 

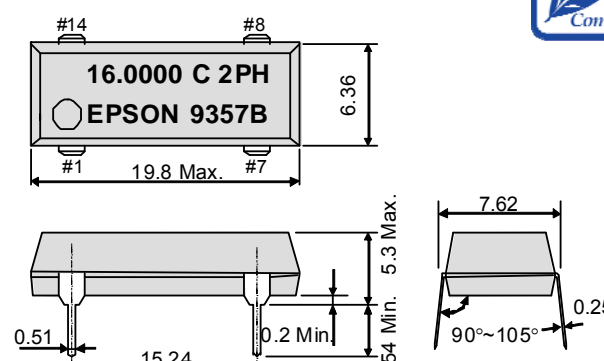

Note.

- OE Pin (PT, PH, PC)
- OE Pin = "H" or "open": Specified frequency output.
- OE Pin = "L": Output is high impedance.

- \overline{ST} Pin (ST, SH, SC)
- ST Pin = "H" or "open": Specified frequency output.
- ST Pin = "L": Output is low level (weak pull - down), oscillation stops.

Pin map

Pin	Connection
1	OE or \overline{ST}
2	GND
3	OUT
4	VCC

Pin map: SG-8002DC

Pin	Connection
1	OE or \overline{ST}
4	GND
5	OUT
8	VCC

Pin map: SG-8002DB

Pin	Connection
1	OE or \overline{ST}
7	GND
8	OUT
14	VCC

To maintain stable operation, provide a 0.01uF to 0.1uF by-pass capacitor at a location as near as possible to the power source terminal of the crystal product (between Vcc - GND).

Products number

(Please contact us for each product.)

- SG-8002CE: Q3321CExxxxx00
- SG-8002LB: Q3323LBxxxxx00
- SG-8002CA: Q3309CAx0xxxx00
- SG-8002JF: Q3308JFx2xxxx00

- SG-8002JC: Q3307JCx2xxxx00
- SG-8002JA: Q3306JAx2xxxx00
- SG-8002DC: Q3204DCx2xxxx00
- SG-8002DB: Q3203DBx2xxxx00

SG-8002 Series Outline of specifications

Model		Supply voltage	Operating temperature	Output load condition	Symmetry		Output rise time / Output fall time	
SG-8002CE	PT/ST	4.5 V to 5.5 V	-20 °C to +70 °C	5TTL+15pF	40 % to 60 % (1.4 V, L_TTL=5 TTL+15 pF, f0≤125 MHz)	2.0 ns Max. (0.8 V to 2.0 V, L_TTL=Max.)	4.0 ns Max. (0.4 V to 2.4 V, L_TTL=Max.)	
			-40 °C to +85 °C		45 % to 55 % (1.4 V, L_TTL=5 TTL+15 pF, f0≤66.7 MHz)			
	PH/SH	-20 °C to +70 °C	15 pF (f0≤125 MHz)	40 % to 60 % (50 % VCC, L_CMOS=15 pF, f0≤125 MHz)	3.0 ns Max. (20 % VCC to 80 % VCC, L_CMOS=Max.)			
-40 °C to +85 °C	25 pF (f0≤100 MHz)	45 % to 55 % (50 % VCC, L_CMOS=25 pF, f0≤66.7 MHz)						
PC/SC	3.0 V to 3.6 V 2.7 V to 3.6 V	-40 °C to +85 °C	15 pF	40 % to 60 % (50 % VCC, L_CMOS=15 pF, f0≤125 MHz)	3.0 ns Max. (20 % VCC to 80 % VCC, L_CMOS=Max.)			
				45 % to 55 % (50 % VCC, L_CMOS=15 pF, f0≤40 MHz)				
SG-8002LB	PH/SH	4.5 V to 5.5 V	-40 °C to +85 °C	15 pF 25pF (f0≤50 MHz)	40 % to 60 % (50 % VCC, L_CMOS=15 pF, f0≤80 MHz)	3.0 ns Max. (20 % VCC to 80 % VCC, L_CMOS=Max.)		
					45 % to 55 % (50 % VCC, L_CMOS=25 pF, f0≤50 MHz)			
PC/SC	3.0 V to 3.6 V 2.7 V to 3.6 V	-40 °C to +85 °C	15 pF	40 % to 60 % (50 % VCC, L_CMOS=15 pF, f0≤125 MHz)	3.0 ns Max. (20 % VCC to 80 % VCC, L_CMOS=Max.)			
				45 % to 55 % (50 % VCC, L_CMOS=15 pF, f0≤40 MHz)				
SG-8002JF	PT/ST	4.5 V to 5.5 V	-20 °C to +70 °C	5TTL+15 pF (f0≤90 MHz)	40 % to 60 % (1.4 V, L_TTL=5 TTL+15 pF, f0≤90 MHz)	2.0 ns Max. (0.8 V to 2.0 V, L_CMOS≤25pF)	4.0 ns Max. (0.4 V to 2.4 V, L_CMOS or L_TTL=Max.)	
			-40 °C to +85 °C	15 pF (f0≤125 MHz)	45 % to 55 % (1.4 V, L_TTL=5 TTL+15 pF, f0≤66.7 MHz)			
	PH/SH	-20 °C to +70 °C	15 pF (f0≤125 MHz)	40 % to 60 % (1.4 V, L_CMOS=15 pF, f0≤40 MHz)	3.0 ns Max. (20 % VCC to 80 % VCC, L_CMOS≤25pF)			
			25 pF (f0≤90 MHz)	45 % to 55 % (50 % VCC, L_CMOS=25 pF, f0≤90.0 MHz)				
	-40 °C to +85 °C	50 pF (f0≤66.7 MHz)	40 % to 60 % (50 % VCC, L_CMOS=50 pF, f0≤50.0 MHz)	45 % to 55 % (50 % VCC, L_CMOS=25 pF, f0≤66.7 MHz)	4.0 ns Max. (20 % VCC to 80 % VCC, L_CMOS=Max.)			
		15 pF (f0≤40 MHz)	40 % to 60 % (50 % VCC, L_CMOS=15 pF, f0≤40 MHz)					
PC/SC	3.0 V to 3.6 V 2.7 V to 3.6 V	-40 °C to +85 °C	15 pF	40 % to 60 % (50 % VCC, CL=15 pF, f0≤125 MHz)	3.0 ns Max. (20 % VCC to 80 % VCC, L_CMOS≤15pF)			
			30 pF (f0≤40 MHz)	45 % to 55 % (50 % VCC, CL=30 pF, f0≤40 MHz)				
15 pF	40 % to 60 % (50 % VCC, CL=15 pF, f0≤66.7 MHz)	4.0 ns Max. (20 % VCC to 80 % VCC, L_CMOS=Max.)						
SG-8002CA	PT/ST	4.5 V to 5.5 V	-20 °C to +70 °C	5TTL+15pF (f0≤125 MHz)	40 % to 60 % (1.4 V, L_TTL=5 TTL+15 pF, f0≤125 MHz)	2.0 ns Max. (0.8 V to 2.0 V, L_CMOS or L_TTL=Max.)	4.0 ns Max. (0.4 V to 2.4 V, L_CMOS or L_TTL=Max.)	
			-40 °C to +85 °C	25 pF (f0≤66.7 MHz)	45 % to 55 % (1.4 V, L_TTL=5 TTL+15 pF, f0≤66.7 MHz)			
SG-8002JA	PH/SH	-20 °C to +70 °C	5 TTL+15 pF (f0≤40 MHz)	40 % to 60 % (1.4 V, L_CMOS=15 pF, f0≤55.0 MHz)	3.0 ns Max. (20 % VCC to 80 % VCC, L_CMOS≤25pF)			
			15 pF (f0≤55 MHz)	45 % to 55 % (1.4 V, L_TTL=5 TTL+15 pF, f0≤40.0 MHz)				
SG-8002DB	-40 °C to +85 °C	25 pF (f0≤125 MHz)	40 % to 60 % (50 % VCC, L_CMOS=25 pF, f0≤125 MHz)	4.0 ns Max. (20 % VCC to 80 % VCC, L_CMOS=Max.)				
		50 pF (f0≤66.7 MHz)	45 % to 55 % (50 % VCC, L_CMOS=50 pF, f0≤66.7 MHz)					
SG-8002DC	15 pF (f0≤55 MHz)	40 % to 60 % (50 % VCC, L_CMOS=15 pF, f0≤55.0 MHz)	45 % to 55 % (50 % VCC, L_CMOS=25 pF, f0≤40.0 MHz)	3.0 ns Max. (20 % VCC to 80 % VCC, L_CMOS≤15pF)				
		25 pF (f0≤40 MHz)	40 % to 60 % (50 % VCC, L_CMOS=25 pF, f0≤40.0 MHz)					
PC/SC	3.0 V to 3.6 V 2.7 V to 3.6 V	-40 °C to +85 °C	15 pF	40 % to 60 % (50 % VCC, L_CMOS=15 pF, f0≤125 MHz)	4.0 ns Max. (20 % VCC to 80 % VCC, L_CMOS=Max.)			
			30 pF (f0≤40 MHz)	45 % to 55 % (50 % VCC, L_CMOS=30 pF, f0≤40 MHz)				
15 pF	40 % to 60 % (50 % VCC, L_CMOS=15 pF, f0≤66.7 MHz)							
SG-8002JC	PT/ST	4.5 V to 5.5 V	-20 °C to +70 °C	5TTL+15 pF (f0≤90 MHz)	40 % to 60 % (1.4 V, L_CMOS=15 pF, f0≤125 MHz)	2.0 ns Max. (0.8 V to 2.0 V, L_CMOS or L_TTL=Max.)	4.0 ns Max. (0.4 V to 2.4 V, L_CMOS or L_TTL=Max.)	
			-40 °C to +85 °C	15 pF (f0≤125 MHz)	45 % to 55 % (1.4 V, L_TTL=5 TTL+15 pF, f0≤66.7 MHz)			
	PH/SH	-20 °C to +70 °C	15 pF (f0≤125 MHz)	40 % to 60 % (50 % VCC, L_CMOS=15 pF, f0≤125 MHz)	3.0 ns Max. (20 % VCC to 80 % VCC, L_CMOS≤25pF)			
			25 pF (f0≤90 MHz)	45 % to 55 % (50 % VCC, L_CMOS=25 pF, f0≤90 MHz)				
	-40 °C to +85 °C	50 pF (f0≤66.7 MHz)	40 % to 60 % (50 % VCC, L_CMOS=50 pF, f0≤50 MHz)	45 % to 55 % (50 % VCC, L_CMOS=25 pF, f0≤66.7 MHz)	4.0 ns Max. (20 % VCC to 80 % VCC, L_CMOS=Max.)			
		15 pF (f0≤40 MHz)	40 % to 60 % (50 % VCC, L_CMOS=15 pF, f0≤40 MHz)					
PC/SC	3.0 V to 3.6 V 2.7 V to 3.6 V	-20 °C to +70 °C	15 pF	40 % to 60 % (50 % VCC, L_CMOS=15 pF, f0≤125 MHz)	3.0 ns Max. (20 % VCC to 80 % VCC, L_CMOS≤15pF)			
			30 pF (f0≤40 MHz)	45 % to 55 % (50 % VCC, L_CMOS=30 pF, f0≤40 MHz)				
15 pF	40 % to 60 % (50 % VCC, L_CMOS=15 pF, f0≤66.7 MHz)	4.0 ns Max. (20 % VCC to 80 % VCC, L_CMOS=Max.)						

▶ TABLE OF FREQUENCY RANGE

Model	Supply voltage	Frequency	Frequency tolerance Operating Temperature
SG-8002CE	PT/ ST PH/ SH	4.5 V to 5.5 V	1.0 MHz to 125 MHz B, C
		3.0 V to 3.6 V 2.7 V to 3.6 V	1.0 MHz to 27 MHz M
	PC/SC	1.0 MHz to 66.7 MHz B, C, M	
SG-8002LB	PH/ SH	4.5 V to 5.5 V	1.0 MHz to 80 MHz B, C
		3.0 V to 3.6 V 2.7 V to 3.6 V	1.0 MHz to 27 MHz M, L
	PC/ SC	1.0 MHz to 125 MHz B, C, M, L	
SG-8002JF	PT/ ST PH/ SH	4.5 V to 5.5 V	1.0 MHz to 125 MHz B, C
		3.0 V to 3.6 V 2.7 V to 3.6 V	1.0 MHz to 40 MHz M
	PC/ SC	1.0 MHz to 125 MHz B, C, M	
SG-8002CA SG-8002JA SG-8002DB SG-8002DC	PT/ ST PH/ SH	4.5 V to 5.5 V	1.0 MHz to 125 MHz B, C
		3.0 V to 3.6 V 2.7 V to 3.6 V	1.0 MHz to 55 MHz M
	PC/ SC	1.0 MHz to 125 MHz B, C, M	
SG-8002JC	PT/ ST PH/ SH	4.5 V to 5.5 V	1.0 MHz to 125 MHz B, C
		3.0 V to 3.6 V 2.7 V to 3.6 V	1.0 MHz to 125 MHz B, C
	PC/ SC	1.0 MHz to 66.7 MHz B, C	

 Frequency tolerance: B:±50×10⁻⁶ (-20 °C to +70 °C), C:±100×10⁻⁶ (-20 °C to +70 °C), M:±100×10⁻⁶ (-40 °C to +85 °C), L:±50×10⁻⁶ (-40 °C to +85 °C)



SG-8002 series Jitter specifications and characteristics chart

■ PLL-PLL connection

Because we use a PLL technology, there are a few cases that the jitter value will increase when SG-8002 is connected to another PLL-oscillator.

In our experience, we are unable to recommend these products for the applications such as telecom carrier use or analog video clock use. Please be careful checking in advance for these application (Jitter specification is Max.250 ps/CL=15 pF)

Jitter Specifications

Model	Supply Voltage	Jitter Item	Specifications	Remarks
PT / PH ST / SH	5.0 V ±0.5 V	Cycle to cycle	150 ps Max.	33 MHz ≤ f _o ≤ 125 MHz, L_CMOS=15 pF
			200 ps Max.	1.0 MHz ≤ f _o < 33 MHz, L_CMOS=15 pF
		Peak to peak	200 ps Max.	33 MHz ≤ f _o ≤ 125 MHz, L_CMOS=15 pF
			250 ps Max.	1.0 MHz ≤ f _o < 33 MHz, L_CMOS=15 pF
SC / PC	3.3 V ±0.3 V	Cycle to cycle	200 ps Max.	1.0 MHz ≤ f _o ≤ 125 MHz, L_CMOS=15 pF
		Peak to peak	250 ps Max.	1.0 MHz ≤ f _o ≤ 125 MHz, L_CMOS=15 pF

■ Remarks on noise management for power supply line

We do not recommend inserting filters or other devices in the power supply line as the counter measure of EMI noise reduction. This device insertion might cause high-frequency impedance high in the power supply line and it affects oscillator stable drive. When this measure is required, please evaluate circuitry and device behavior in the circuit and verify that it will not affect oscillation. Start up time (0 % V_{cc} to 90 % V_{cc}) of power source should be more than 150 μs.

■ SG-8002 series Characteristics chart

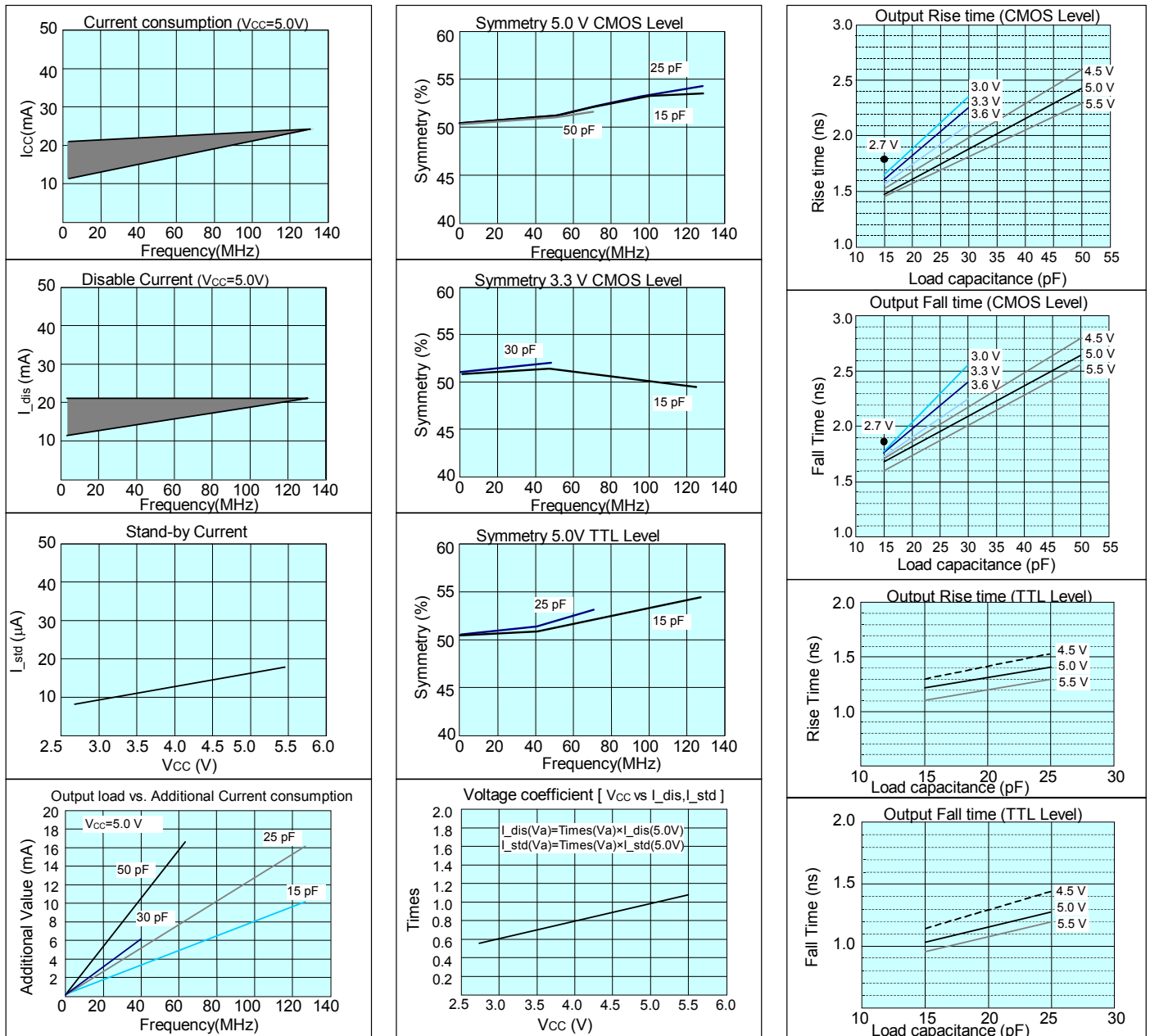

PROMOTION OF ENVIRONMENTAL MANAGEMENT SYSTEM CONFORMING TO INTERNATIONAL STANDARDS

At Seiko Epson, all environmental initiatives operate under the Plan-Do-Check-Action (PDCA) cycle designed to achieve continuous improvements. The environmental management system (EMS) operates under the ISO 14001 environmental management standard.

All of our major manufacturing and non-manufacturing sites, in Japan and overseas, completed the acquisition of ISO 14001 certification.

ISO 14000 is an international standard for environmental management that was established by the International Standards Organization in 1996 against the background of growing concern regarding global warming, destruction of the ozone layer, and global deforestation.



WORKING FOR HIGH QUALITY

In order provide high quality and reliable products and services than meet customer needs,

Seiko Epson made early efforts towards obtaining ISO9000 series certification and has acquired ISO9001 for all business establishments in Japan and abroad. We have also acquired ISO/TS 16949 certification that is requested strongly by major automotive manufacturers as standard.

ISO/TS16949 is the international standard that added the sector-specific supplemental requirements for automotive industry based on ISO9001.

► Explanation of the mark that are using it for the catalog

	► Pb free.
	► Complies with EU RoHS directive. *About the products without the Pb-free mark. Contains Pb in products exempted by EU RoHS directive. (Contains Pb in sealing glass, high melting temperature type solder or other.)
	► The products have been designed for high reliability applications such as Automotive.

Notice

- This material is subject to change without notice.
- Any part of this material may not be reproduced or duplicated in any form or any means without the written permission of Seiko Epson.
- The information about applied circuitry, software, usage, etc. written in this material is intended for reference only. Seiko Epson does not assume any liability for the occurrence of infringing on any patent or copyright of a third party. This material does not authorize the licensing for any patent or intellectual copyrights.
- When exporting the products or technology described in this material, you should comply with the applicable export control laws and regulations and follow the procedures required by such laws and regulations.
- You are requested not to use the products (and any technical information furnished, if any) for the development and/or manufacture of weapon of mass destruction or for other military purposes. You are also requested that you would not make the products available to any third party who may use the products for such prohibited purposes.
- These products are intended for general use in electronic equipment. When using them in specific applications that require extremely high reliability, such as the applications stated below, you must obtain permission from Seiko Epson in advance.
/ Space equipment (artificial satellites, rockets, etc.) / Transportation vehicles and related (automobiles, aircraft, trains, vessels, etc.) / Medical instruments to sustain life / Submarine transmitters / Power stations and related / Fire work equipment and security equipment / traffic control equipment / and others requiring equivalent reliability.
- All brands or product names mentioned herein are trademarks and/or registered trademarks of their respective.