



HARRIS

IRFP240R, IRFP241R IRFP242R, IRFP243R

**N-Channel Power MOSFETs
Avalanche Energy Rated**

August 1991

Features

- 18A and 20A, 200V - 150V
- $r_{DS(on)} = 0.18\Omega$ and 0.22Ω
- Single Pulse Avalanche Energy Rated
- SOA is Power-Dissipation Limited
- Nanosecond Switching Speeds
- Linear Transfer Characteristics
- High Input Impedance

Description

The IRFP240R, IRFP241R, IRFP242R, and IRFP243R are advanced power MOSFETs designed, tested and guaranteed to withstand a specified level of energy in the breakdown avalanche mode of operation. These are n-channel enhancement-mode silicon-gate power field-effect transistors designed for applications such as switching regulators, switching converters, motor drivers, relay drivers, and drivers for high-power bipolar switching transistors requiring high speed and low gate-drive power. These types can be operated directly from integrated circuits.

The IRFP types are supplied in the JEDEC TO-247 plastic package.

Package

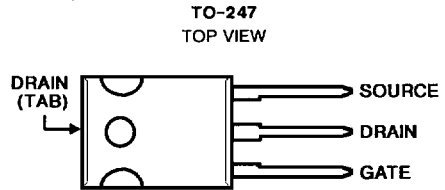

Terminal Diagram

N-CHANNEL ENHANCEMENT MODE

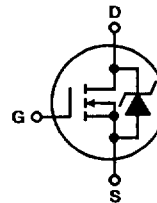

Absolute Maximum Ratings ($T_C = +25^\circ\text{C}$), Unless Otherwise Specified

	IRFP240R	IRFP241R	IRFP242R	IRFP243R	UNITS
Drain-Source Voltage (1)	200	150	200	150	V
Drain-Gate Voltage ($R_{GS} = 20k\Omega$) (1)	200	150	120	150	V
Continuous Drain Current					
$T_C = +25^\circ\text{C}$	20	20	18	18	A
$T_C = +100^\circ\text{C}$	12	12	11	11	A
Pulsed Drain Current (3)	80	80	72	72	A
Gate-Source Voltage	± 20	± 20	± 20	± 20	V
Maximum Power Dissipation					
$T_C = +25^\circ\text{C}$	150	150	150	150	W
Linear Derating Factor	1.2	1.2	1.2	1.2	W/ $^\circ\text{C}$
Single Pulse Avalanche Energy Rating (4)	510	510	510	510	mJ
Operating and Storage Junction	T_J, T_{STG}	-55 to $+150$	-55 to $+150$	-55 to $+150$	$^\circ\text{C}$
Temperature Range					
Maximum Lead Temperature for Soldering	300	300	300	300	$^\circ\text{C}$
(0.063" (1.6mm) from case for 10s)					

NOTES:

- $T_J = +25^\circ\text{C}$ to $+150^\circ\text{C}$.
- Pulse Test: Pulse width $\leq 300\mu\text{s}$, Duty Cycle $\leq 2\%$.
- Repetitive Rating: Pulse width limited by max. junction temperature. See Transient Thermal Impedance Curve (Figure 5).
- $V_{DD} = 50\text{V}$, starting $T_J = +25^\circ\text{C}$, $L = 1.9\text{mH}$, $R_{GS} = 50\Omega$, $I_{PEAK} = 20\text{A}$. See Figures 14 and 15.

Specifications IRFP240R, IRFP241R, IRFP242R, IRFP243R

Electrical Characteristics $T_C = +25^\circ\text{C}$, Unless Otherwise Specified

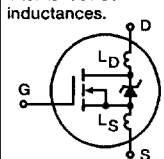
CHARACTERISTIC	SYMBOL	TEST CONDITIONS	LIMITS			UNITS	
			MIN	TYP	MAX		
Drain-Source Breakdown Voltage IRFP240R, IRFP242R IRFP241R, IRFP243R	BV _{DSS}	V _{GS} = 0V, I _D = 250μA	200	-	-	V	
			150	-	-	V	
Gate Threshold Voltage	V _{GS(TH)}	V _{DS} = V _{GS} , I _D = 250μA	2.0	-	4.0	V	
Gate-Source Leakage Forward	I _{GSS}	V _{GS} = 20V	-	-	100	nA	
Gate-Source Leakage Reverse	I _{GSS}	V _{GS} = -20V	-	-	-100	nA	
Zero Gate Voltage Drain Current	I _{DSS}	V _{DS} = Max Rating, V _{GS} = 0V	-	-	250	μA	
		V _{DS} = Max Rating x 0.8, V _{GS} = 0V, T _J = +125°C	-	-	1000	μA	
On-State Drain Current (Note 2) IRFP240R, IRFP241R IRFP242R, IRFP243R	I _{D(ON)}	V _{DS} > I _{D(ON)} × r _{DS(ON)} Max, V _{GS} = 11V	20	-	-	A	
			18	-	-	A	
Static Drain-Source On-State Resistance (Note 2) IRFP240R, IRFP241R IRFP242R, IRFP243R	r _{DS(ON)}	V _{GS} = 10V, I _D = 10A	-	0.14	0.18	Ω	
			-	0.20	0.22	Ω	
Forward Transconductance (Note 2)	g _{fs}	V _{DS} ≥ 50V, I _D = 11A	7.3	11	-	S(25)	
Input Capacitance	C _{iSS}	V _{GS} = 0V, V _{DS} = 25V, f = 1.0MHz See Figure 10	-	1275	-	pF	
Output Capacitance	C _{oss}		-	500	-	pF	
Reverse Transfer Capacitance	C _{rSS}		-	160	-	pF	
Turn-On Delay Time	t _{d(ON)}	V _{DD} = 100V, I _D = 18A, R _G = 9.1Ω See Figure 16. (MOSFET switching times are essentially independent of operating temperature)	-	14	21	ns	
Rise Time	t _r		-	51	77	ns	
Turn-Off Delay Time	t _{d(OFF)}		-	45	68	ns	
Fall Time	t _f		-	36	54	ns	
Total Gate Charge (Gate-Source + Gate-Drain)	Q _g		-	43	60	nC	
Gate-Source Charge	Q _{gs}	V _{GS} = 10V, I _D = 18A, V _{DS} = 0.8 Max Rating. See Figure 17 for test circuit. (Gate charge is essentially independent of operating temperature.)	-	10	-	nC	
Gate-Drain ("Miller") Charge	Q _{gd}		-	32	-	nC	
Internal Drain Inductance	L _D	Measured between the contact screw on header that is closer to source and gate pins and center of die.		-	5.0	-	nH
Internal Source Inductance	L _S	Measured from the source lead, 6mm (0.25") from header and source bonding pad.		-	12.5	-	nH
Junction-to-Case	R _{θJC}	-	-	-	0.83	°C/W	
Case-to-Sink	R _{θCS}	Mounting surface flat, smooth and greased	-	0.1	-	°C/W	
Junction-to-Ambient	R _{θJA}	Free air operation	-	-	30	°C/W	

Source Drain Diode Ratings and Characteristics

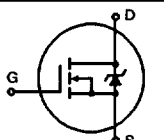
Continuous Source Current (Body Diode)	I _S	Modified MOSFET symbol showing the integral reverse P-N Junc. rectifier.		-	-	20	A
Pulse Source Current (Body Diode) (Note 3)	I _{SM}			-	-	80	A
Diode Forward Voltage (Note 2)	V _{SD}	T _J = +25°C, I _S = 18A, V _{GS} = 0V	-	-	2.0	V	
Reverse Recovery Time	t _{rr}	T _J = +25°C, I _F = 18A, dI _F /dt = 100A/μs	120	250	530	ns	
Reverse Recovered Charge	Q _{RR}	T _J = +25°C, I _F = 18A, dI _F /dt = 100A/μs	1.3	2.6	5.6	μC	
Forward Turn-on Time	t _{ON}	Intrinsic turn-on time is negligible. Turn-on speed is substantially controlled by L _S + L _D .	-	-	-	-	

NOTES: 1. T_J = +25°C to +150°C

2. Pulse Test: Pulse width ≤ 300μs, Duty Cycle ≤ 2%

3. Repetitive Rating: Pulse width limited by max. junction temperature. See Transient Thermal Impedance Curve (Figure 5)

4. V_{DD} = 50V, Start T_J = +25°C, L = 1.9mH, R_{GS} = 50Ω, I_{PEAK} = 20A. (See Figures 14 & 15)

4

N-CHANNEL POWER MOSFETs

IRFP240R, IRFP241R, IRFP242R, IRFP243R

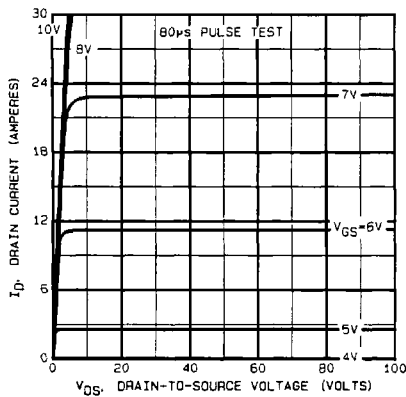

FIGURE 1. TYPICAL OUTPUT CHARACTERISTICS

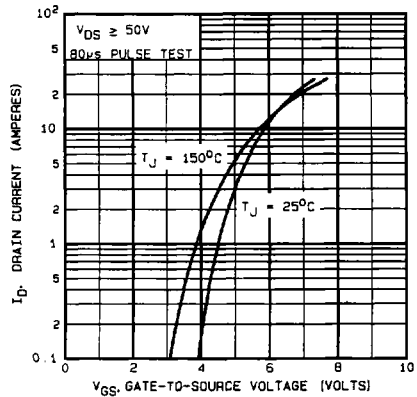

FIGURE 2. TYPICAL TRANSFER CHARACTERISTICS

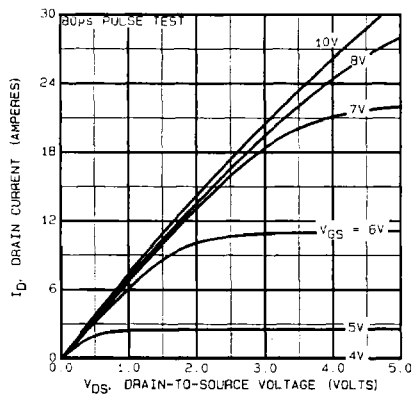

FIGURE 3. TYPICAL SATURATION CHARACTERISTICS

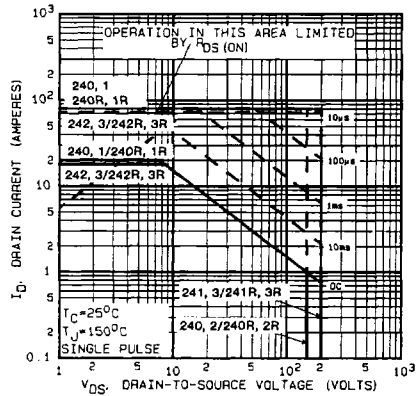

FIGURE 4. MAXIMUM SAFE OPERATING AREA

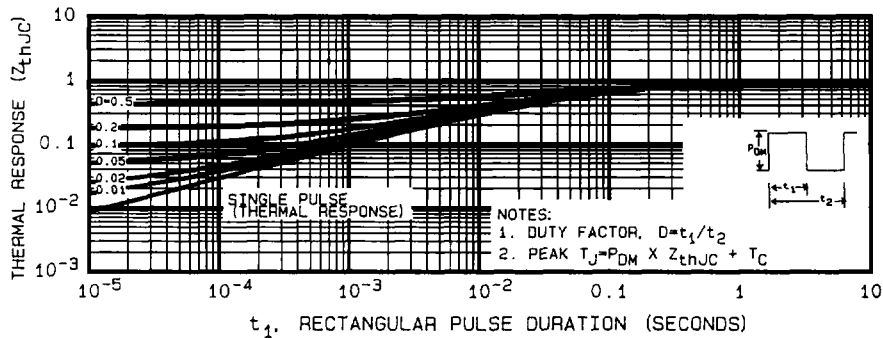

FIGURE 5. MAXIMUM EFFECTIVE TRANSIENT THERMAL IMPEDANCE, JUNCTION-TO-CASE vs PULSE DURATION

IRFP240R, IRFP241R, IRFP242R, IRFP243R

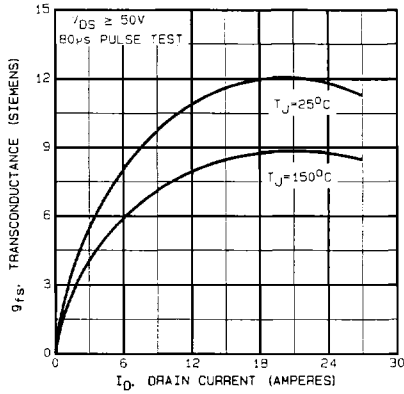

FIGURE 6. TYPICAL TRANSCONDUCTANCE vs DRAIN CURRENT

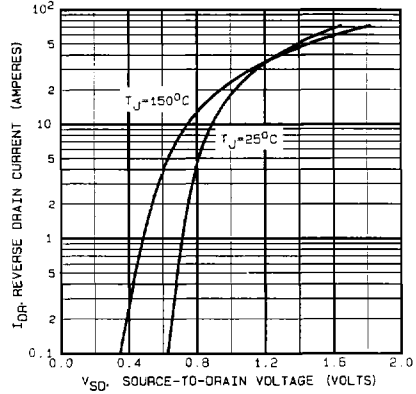

FIGURE 7. TYPICAL SOURCE-DRAIN DIODE FORWARD VOLTAGE

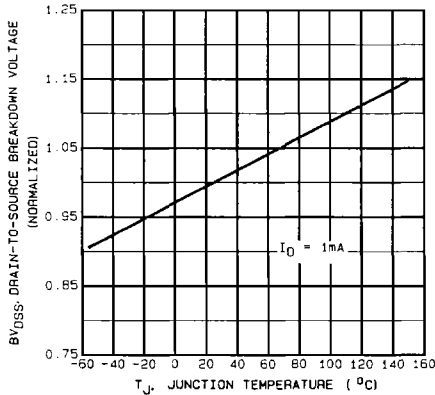

FIGURE 8. BREAKDOWN VOLTAGE vs TEMPERATURE

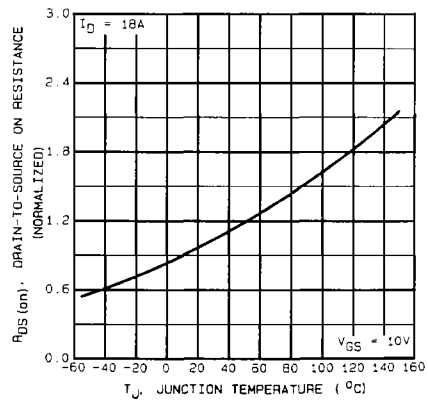

FIGURE 9. NORMALIZED ON-RESISTANCE vs TEMPERATURE

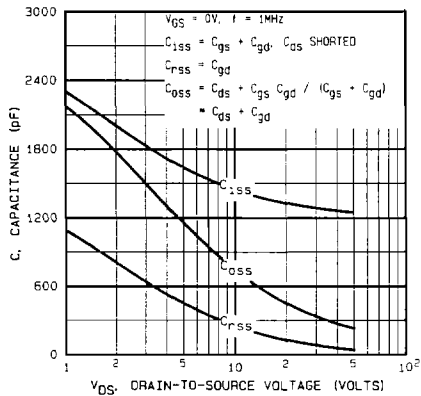

FIGURE 10. TYPICAL CAPACITANCE vs DRAIN-TO-SOURCE VOLTAGE

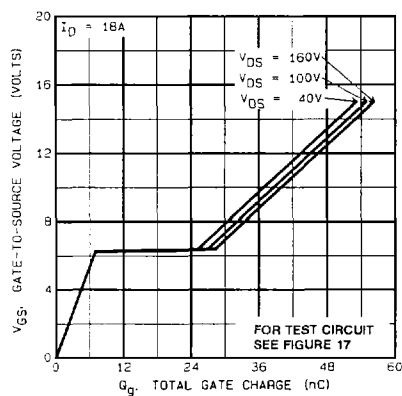

FIGURE 11. TYPICAL GATE CHARGE vs GATE-TO-SOURCE VOLTAGE

4
N-CHANNEL
POWER MOSFETS

IRFP240R, IRFP241R, IRFP242R, IRFP243R

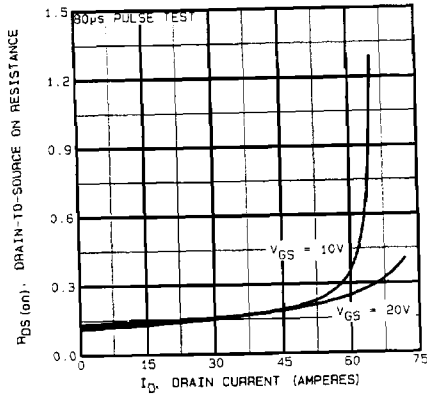

FIGURE 12. TYPICAL ON-RESISTANCE VS DRAIN CURRENT

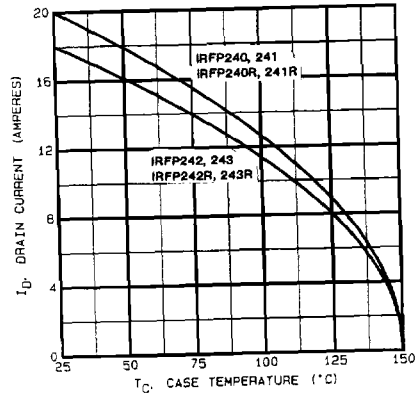

FIGURE 13. MAXIMUM DRAIN CURRENT VS CASE TEMPERATURE

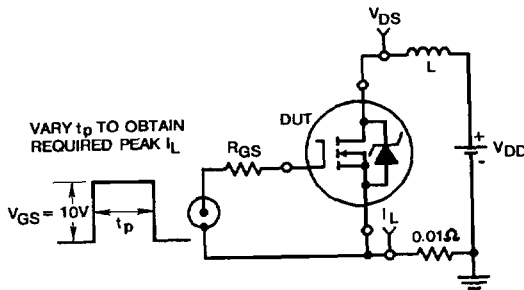

FIGURE 14. UNCLAMPED ENERGY TEST CIRCUIT

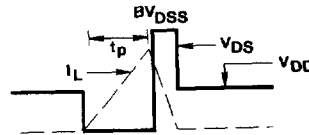

FIGURE 15. UNCLAMPED ENERGY WAVEFORMS

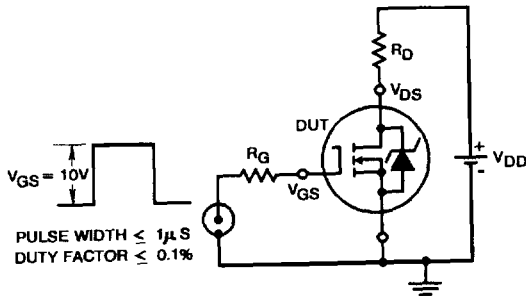

FIGURE 16. SWITCHING TIME TEST CIRCUIT

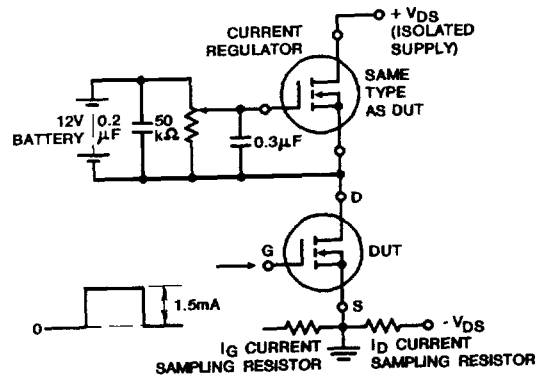

FIGURE 17. GATE CHARGE TEST CIRCUIT