

**SPECIFICATIONS**

**VGA Connector**

**Mechanical**

**Contact Engagement Force:** 0.34kg (0.75Lb) max.  
**Contact Separation Force:** 0.021kg (0.05Lb) min.  
**Durability:** 500 Cycles

**Electrical**

**Current Rating:** 2A  
**Contact Resistance:** 25mW max.  
**Dielectric Withstanding Voltage:** 1000V AC/1min min.  
**Insulation Resistance:** 5000MW min.

**Physical**

**Housing:** Thermoplastic, UL 94V-0 rated in Blue 661C Color  
**Contact:** Copper alloy  
**Plating:** See "ORDERING INFORMATION"  
**Operating Temperature:** -20 to +85  
**Recommended Thickness of PCB:** 1.57[.062]

**DZ Series**  
**Right Angle Type, T/H**  
**2.29mm [.090"] Pitch**  
**15 Pos.**

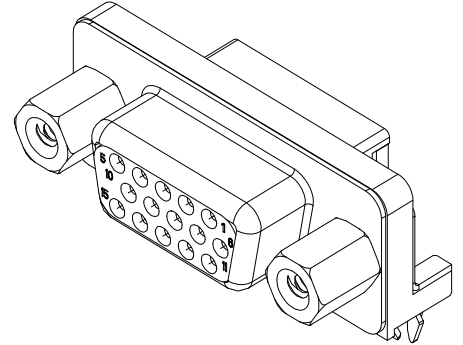

**DRAWING**

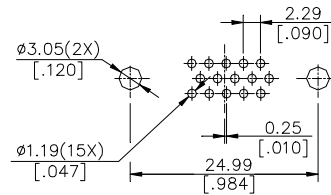
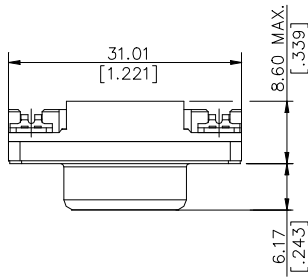

RECOMMENDED P.C.B. LAYOUT

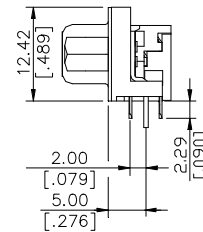
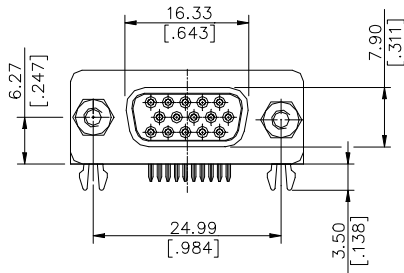

**ORDERING INFORMATION**

**PRODUCT NO.:** DZ 1 1 A A \* - H5N1 - 4F

