

Dual D-Type Positive-Edge Triggered Flip-Flop

Each of the two independent positive edge-triggered flip-flops in this circuit has individual \overline{D} , clock, clear and preset inputs, and complementary Q and \overline{Q} outputs.

- AVG's LS operates over extended V_{CC} from 4.5 to 5.5 V
- AVG's LS and ALS both have guaranteed DC and AC specification over full temperature and V_{CC} range
- Switching specifications for ALS at 50 pF
- AVG's ALS has the lowest speed power product (4pJ per gate typical) of all logic series

DV74LS74A
DV74ALS74A

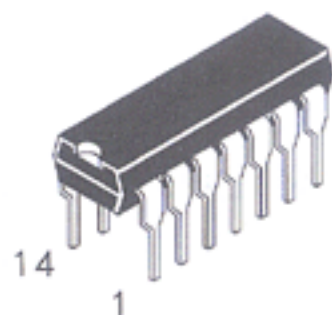

N Suffix
Plastic DIP
AVG-001Case

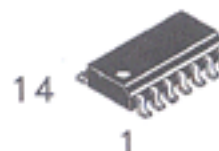

D Suffix
Plastic SOP
AVG-002 Case

PIN ASSIGNMENT

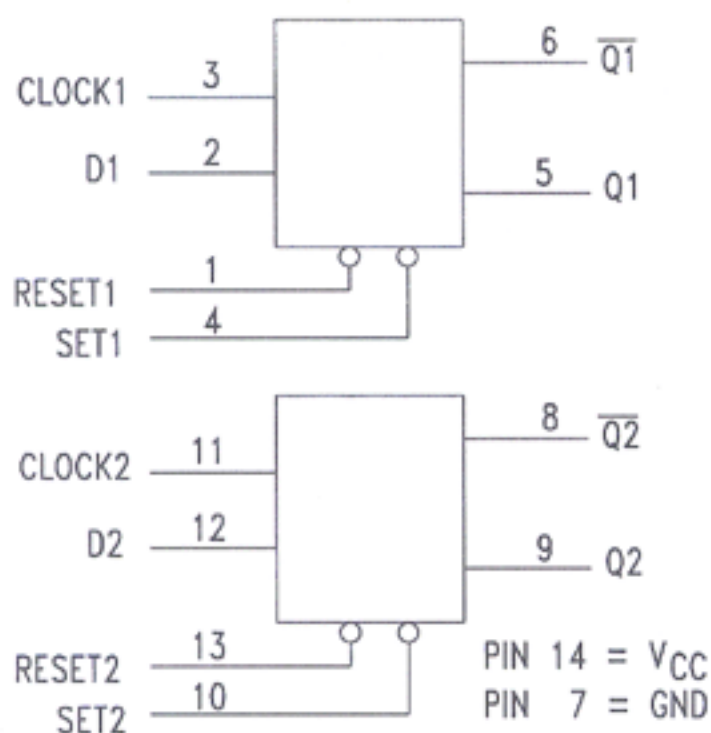

TRUTH TABLE

Inputs				Outputs	
SET	RESET	CLOCK	D	Q	\overline{Q}
L	H	X	X	H	L
H	L	X	X	L	H
L	L	X	X	H*	H*
H	H	↑	H	H	L
H	H	↑	L	L	H
H	H	L	X	Q	\overline{Q}

H=High Level Logic
L=Low Level Logic
X = Either Low or High Logic Level
↑ = Positive Edge Transition
Q = Previous Condition of Q
* = This condition is nonstable, it will not persist when preset and clear inputs return to their inactive (high) level. The output levels in this condition are not guaranteed to meet the V_{OH} specification.

ABSOLUTE MAXIMUM RATINGS

Maximum ratings are those values beyond which damage to the device may occur.

Symbol	Parameter	LS74A	ALS74A	Unit
V_{CC}	Supply Voltage	+7.0	7.0	V
V_{IN}	Input Voltage	0.5 to 7	7.0	V
T_{STG}	Storage Temperature Range	-65 to+150	-65 to+150	°C

GUARANTEED OPERATING CONDITIONS over full range

Symbol	Parameter	LS74A		ALS74A		Unit
		Min	Max	Min	Max	
V _{CC}	Supply Voltage	4.5	5.5	4.5	5.5	V
V _{IH}	High Level Input Voltage	2.0		2.0		V
V _{IL}	Low Level Input Voltage		0.8		0.8	V
I _{OH}	High Level Output Current		-0.4		-0.4	mA
I _{OL}	Low Level Output Current		8		8	mA
T _A	Ambient Temperature Range	-10 to +70		-10 to +70		°C

DC ELECTRICAL CHARACTERISTICS over full operating conditions

Symbol	Parameter	Conditions	LS74A			ALS74A			Unit
			Min	Typ	Max	Min	Typ	Max	
V _{IK}	Input Clamp Voltage	V _{CC} = min, I _{IN} = -18 mA			-1.5			-1.5	V
V _{OH}	High Level Output Voltage	V _{CC} =min, I _{OH} =max	V _{CC} -2	3.5		V _{CC} -2			V
V _{OL}	Low Level Output Voltage	V _{CC} =min; I _{OL} =4.0 mA		0.25	0.4		0.25	0.4	V
		V _{CC} =min; I _{OL} =8.0 mA		0.35	0.5		0.35	0.5	V
I _{IH}	High Level Input Current: V _{CC} =max, V _{IH} = 2.7V	Data, Clock			20			20	μA
		Set, Reset			40			40	μA
	V _{CC} =max, V _{IH} = 7V	Data, Clock			0.1			0.1	mA
		Set, Reset			0.2			0.2	mA
I _{IL}	Low Level Input Current V _{CC} =max, V _{IN} =0.4V	Data, Clock			-0.4			-0.2	mA
		Set, Reset			-0.8			-0.4	mA
I _o	Short Circuit Current	V _{CC} =max; V _O =2.25V	-20		-110	-30		-112	mA
I _{CC}	Supply Current	V _{CC} =max			8.0		2.4	4	mA

SWITCHING CHARACTERISTICS over full operating conditions

Symbol	Parameter	LS74A C _L = 15 pF		ALS74A C _L =50 pF R _L =500Ω		Unit
		Min	Max	Min	Max	
f _{MAX}	Maximum Clock Frequency	25		34		MHz
t _{PLH}	Set or Reset to Output (Q or \bar{Q})		25	3	13	ns
t _{PHL}	Set or Reset to Output (Q or \bar{Q})		40	5	15	ns
t _{PLH}	Clock to Output (Q or \bar{Q})		25	5	16	ns
t _{PHL}	Clock to Output (Q or \bar{Q})		40	5	18	ns
t _{rec}	Clock Recovery Time	15		10		ns

AC SETUP REQUIREMENTS over full operating conditions

Symbol	Parameter	LS74A		ALS74A		Unit
		Min	Max	Min	Max	
t_w	Clock	25		14.5		ns
t_w	Set, Reset	25		15		ns
t_s	Data Setup Time	20		15		ns
t_h	Hold Time	5.0		0		ns

SWITCHING WAVEFORMS

