

SN74LVC157 QUADRUPLE 2-LINE TO 1-LINE DATA SELECTOR/MULTIPLEXER

JANUARY 1993

- **Space-Saving Package Option:**
Shrink Small-Outline Package (DB)
Features EIAJ 0.65-mm Lead Pitch
- **EPIC™ (Enhanced-Performance Implanted CMOS) Submicron Process**
- **Designed to Facilitate Incident Wave Switching for Line Impedances of 50 Ω or Greater**
- **Typical V_{OLP} (Output Ground Bounce)**
< 0.8 V at $V_{CC} = 3.3$ V, $T_A = 25^\circ\text{C}$
- **Typical V_{OHV} (Output V_{OH} Undershoot)**
> 2 V at $V_{CC} = 3.3$ V, $T_A = 25^\circ\text{C}$
- **ESD Protection Exceeds 2000 V Per MIL-STD-883C, Method 3015; Exceeds 200 V Using Machine Model (C = 200 pF, R = 0)**
- **Latch-Up Performance Exceeds 250 mA Per JEDEC Standard JESD-17**
- **Package Options Include Plastic Small-Outline and Thin Shrink Small-Outline Packages**

DB, DW, OR PW PACKAGE
(TOP VIEW)

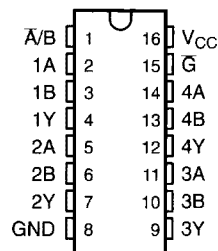

description

This quadruple 2-line to 1-line data selector/multiplexer is designed for 2.7-V to 3.6-V V_{CC} operation.

The SN74LVC157 contains inverters and drivers to supply full data selection to the four output gates. A separate strobe (\bar{G}) input is provided. A 4-bit word is selected from one of two sources and is routed to the four outputs. The SN74LVC157 provides true data.

The SN74LVC157 is packaged in TI's shrink small-outline package (DB), which provides the same I/O pin count and functionality of standard small-outline packages in less than half the printed-circuit-board area.

The SN74LVC157 is characterized for operation from -40°C to 85°C .

FUNCTION TABLE

INPUTS				OUTPUT
\bar{G}	A/B	A	B	Y
H	X	X	X	L
L	L	L	X	L
L	L	H	X	H
L	H	X	L	L
L	H	X	H	H

EPIC is a trademark of Texas Instruments Incorporated.

PRODUCT PREVIEW Information concerns products in the formative or design phase of development. Characteristic data and other specifications are design goals. Texas Instruments reserves the right to change or discontinue these products without notice.

Copyright © 1993, Texas Instruments Incorporated

TEXAS
INSTRUMENTS

POST OFFICE BOX 655303 • DALLAS, TEXAS 75265

4-57

PRODUCT PREVIEW

SN74LVC157 QUADRUPLE 2-LINE TO 1-LINE DATA SELECTOR/MULTIPLEXER

JANUARY 1993

logic symbol†

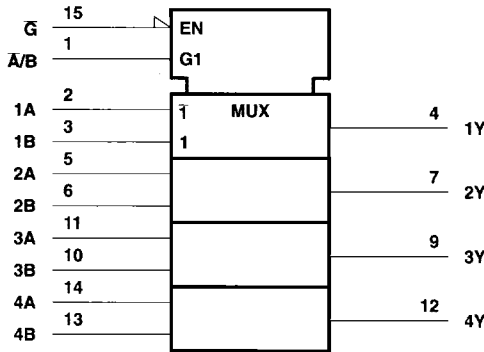

† This symbol is in accordance with ANSI/IEEE Std 91-1984 and IEC Publication 617-12.

logic diagram (positive logic)

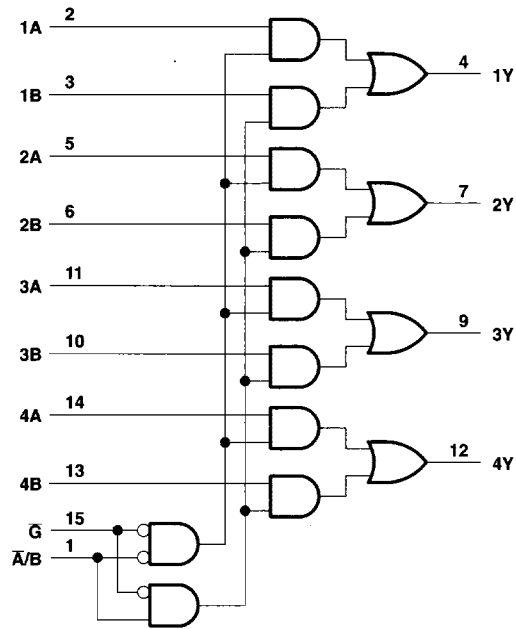

PRODUCT PREVIEW

absolute maximum ratings over operating free-air temperature range (unless otherwise noted)‡

Supply voltage range, V_{CC}	-0.5 V to 4.6 V
Input voltage range, V_I (see Note 1)	-0.5 V to 4.6 V
Output voltage range, V_O (see Notes 1 and 2)	-0.5 V to $V_{CC} + 0.5$ V
Input clamp current, I_{IK} ($V_I < 0$)	-50 mA
Output clamp current, I_{OK} ($V_O < 0$ or $V_O > V_{CC}$)	± 50 mA
Continuous output current, I_O ($V_O = 0$ to V_{CC})	± 50 mA
Continuous current through V_{CC} or GND pins	± 100 mA
Maximum power dissipation at $T_A = 55^\circ\text{C}$ (in still air):	
DB package	0.4 W
DW package	0.85 W
PW package	0.4 W
Storage temperature range	-65°C to 150°C

‡ Stresses beyond those listed under "absolute maximum ratings" may cause permanent damage to the device. These are stress ratings only and functional operation of the device at these or any other conditions beyond those indicated under "recommended operating conditions" is not implied. Exposure to absolute-maximum-rated conditions for extended periods may affect device reliability.

- NOTES: 1. The input and output voltage ratings may be exceeded if the input and output clamp-current ratings are observed.
2. This value is limited to 4.6 V maximum.

SN74LVC157

QUADRUPLE 2-LINE TO 1-LINE DATA SELECTOR/MULTIPLEXER

JANUARY 1993

recommended operating conditions (see Note 3)

		MIN	MAX	UNIT
V _{CC}	Supply voltage	2.7	3.6	V
V _{IH}	High-level input voltage	V _{CC} = 2.7 V to 3.6 V		V
V _{IL}	Low-level input voltage	V _{CC} = 2.7 V to 3.6 V		V
V _I	Input voltage	0	V _{CC}	V
V _O	Output voltage	0	V _{CC}	V
I _{OH}	High-level output current	V _{CC} = 2.7 V		-12
		V _{CC} = 3 V		-24†
I _{OL}	Low-level output current	V _{CC} = 2.7 V		12
		V _{CC} = 3 V		24†
Δt/Δv	Input transition rise or fall rate	0	10	ns/V
T _A	Operating free-air temperature	-40	85	°C

NOTE 3: Unused or floating inputs must be held high or low.

† Current duty cycle ≤ 50%, f ≥ 1 kHz

electrical characteristics over recommended operating free-air temperature range (unless otherwise noted)

PARAMETER	TEST CONDITIONS	V _{CC} ‡	MIN	TYP	MAX	UNIT
V _{IK}	I _I = -18 mA	2.7 V			-1.2	V
V _{OH}	I _{OH} = -100 μA	MIN to MAX	V _{CC} -0.2			V
	I _{OH} = -12 mA	2.7 V	2.2			
	I _{OH} = -24 mA	3 V	2.4			
V _{OL}	I _{OL} = 100 μA	MIN to MAX			0.2	V
	I _{OL} = 12 mA	2.7 V			0.4	
	I _{OL} = 24 mA	3 V			0.55	
I _I	V _I = V _{CC} or GND	3.6 V			±5	μA
I _{OZ}	V _O = V _{CC} or GND	3.6 V			±10	μA
I _{CC}	V _I = V _{CC} or GND, I _O = 0	3.6 V			20	μA
ΔI _{CC}	V _{CC} = 3 V to 3.6 V, One input at V _{CC} - 0.6 V, Other inputs at V _{CC} or GND				500	μA
C _i	V _I = V _{CC} or GND	3.3 V		TBD		pF
C _o	V _O = V _{CC} or GND	3.3 V		TBD		pF

‡ For conditions shown as MIN or MAX, use the appropriate values under recommended operating conditions.

PRODUCT PREVIEW

