

## Octal transceiver with direction pin (3-State)

74ABT245

## FEATURES

- Octal bidirectional bus interface
- 3-State buffers
- Output capability: +64mA/-32mA
- Latch-up protection exceeds 500mA per Jedec Std 17
- ESD protection exceeds 2000 V per MIL STD 883 Method 3015 and 200 V per Machine Model
- Power-up 3-State
- Live insertion/extraction permitted
- Inputs are disabled during 3-State mode

## DESCRIPTION

The 74ABT245 high-performance BiCMOS device combines low static and dynamic power dissipation with high speed and high output drive.

The 74ABT245 device is an octal transceiver featuring non-inverting 3-State bus compatible outputs in both send and receive directions. The control function implementation minimizes external timing requirements. The device features an Output Enable (OE) input for easy cascading and a Direction (DIR) input for direction control.

## QUICK REFERENCE DATA

SYMBOL	PARAMETER	CONDITIONS $T_{amb} = 25^{\circ}\text{C}; \text{GND} = 0\text{V}$	TYPICAL	UNIT
$t_{PLH}$ $t_{PHL}$	Propagation delay An to Bn or Bn to An	$C_L = 50\text{pF}; V_{CC} = 5\text{V}$	2.2 2.9	ns
$C_{IN}$	Input capacitance DIR, OE	$V_I = 0\text{V}$ or $V_{CC}$	4	pF
$C_{IO}$	I/O pin capacitance	Outputs disabled; $V_O = 0\text{V}$ or $V_{CC}$	7	pF
$I_{CCZ}$	Total supply current	Outputs disabled; $V_{CC} = 5.5\text{V}$	50	$\mu\text{A}$

## ORDERING INFORMATION

PACKAGES	TEMPERATURE RANGE	OUTSIDE NORTH AMERICA	NORTH AMERICA	DWG NUMBER
20-Pin Plastic DIP	$-40^{\circ}\text{C}$ to $+85^{\circ}\text{C}$	74ABT245 N	74ABT245 N	SOT146-1
20-Pin plastic SO	$-40^{\circ}\text{C}$ to $+85^{\circ}\text{C}$	74ABT245 D	74ABT245 D	SOT163-1
20-Pin Plastic SSOP Type II	$-40^{\circ}\text{C}$ to $+85^{\circ}\text{C}$	74ABT245 DB	74ABT245 DB	SOT339-1
20-Pin Plastic TSSOP Type I	$-40^{\circ}\text{C}$ to $+85^{\circ}\text{C}$	74ABT245 PW	74ABT245PW DH	SOT360-1

## PIN CONFIGURATION

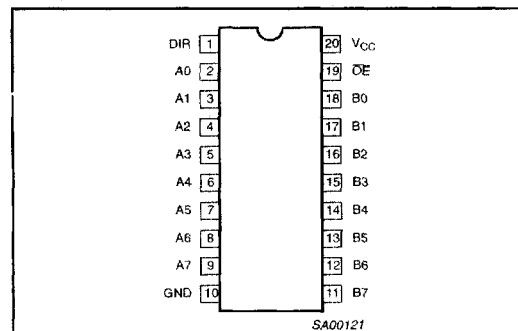

## PIN DESCRIPTION

PIN NUMBER	SYMBOL	NAME AND FUNCTION
1	DIR	Direction control input
2, 3, 4, 5, 6, 7, 8, 9	A0 – A7	Data inputs/outputs (A side)
18, 17, 16, 15, 14, 13, 12, 11	B0 – B7	Data inputs/outputs (B side)
19	OE	Output enable input (active-Low)
10	GND	Ground (0V)
20	$V_{CC}$	Positive supply voltage

# Octal transceiver with direction pin (3-State)

## 74ABT245

### LOGIC SYMBOL

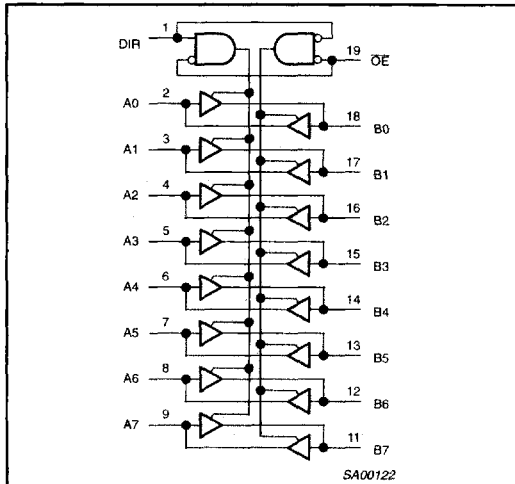

### LOGIC SYMBOL (IEEE/IEC)

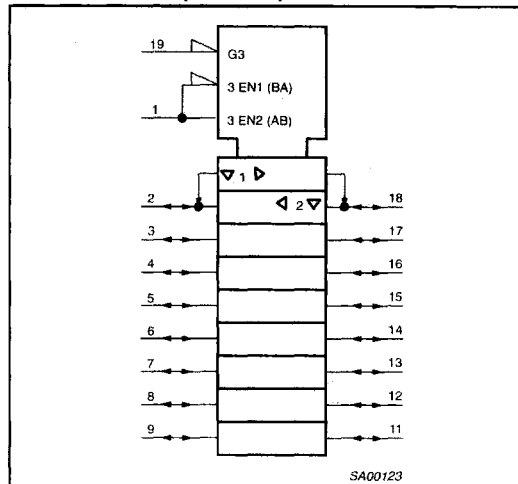

### FUNCTION TABLE

INPUTS		INPUTS/OUTPUTS	
OE	DIR	An	Bn
L	L	An = Bn	Inputs
L	H	Inputs	Bn = An
H	X	Z	Z

H = High voltage level  
 L = Low voltage level  
 X = Don't care  
 Z = High impedance "off" state

### ABSOLUTE MAXIMUM RATINGS<sup>1, 2</sup>

SYMBOL	PARAMETER	CONDITIONS	RATING	UNIT
V <sub>CC</sub>	DC supply voltage		-0.5 to +7.0	V
I <sub>IK</sub>	DC input diode current	V <sub>I</sub> < 0	-18	mA
V <sub>I</sub>	DC input voltage <sup>3</sup>		-1.2 to +7.0	V
I <sub>OK</sub>	DC output diode current	V <sub>O</sub> < 0	-50	mA
V <sub>OUT</sub>	DC output voltage <sup>3</sup>	output in Off or High state	-0.5 to +5.5	V
I <sub>OUT</sub>	DC output current	output in Low state	128	mA
T <sub>stg</sub>	Storage temperature range		-65 to 150	°C

#### NOTES:

- Stresses beyond those listed may cause permanent damage to the device. These are stress ratings only and functional operation of the device at these or any other conditions beyond those indicated under "recommended operating conditions" is not implied. Exposure to absolute-maximum-rated conditions for extended periods may affect device reliability.
- The performance capability of a high-performance integrated circuit in conjunction with its thermal environment can create junction temperatures which are detrimental to reliability. The maximum junction temperature of this integrated circuit should not exceed 150°C.
- The input and output voltage ratings may be exceeded if the input and output current ratings are observed.

## Octal transceiver with direction pin (3-State)

74ABT245

## RECOMMENDED OPERATING CONDITIONS

SYMBOL	PARAMETER	LIMITS		UNIT
		Min	Max	
V <sub>CC</sub>	DC supply voltage	4.5	5.5	V
V <sub>I</sub>	Input voltage	0	V <sub>CC</sub>	V
V <sub>IH</sub>	High-level input voltage	2.0		V
V <sub>IL</sub>	Low-level Input voltage		0.8	V
I <sub>OH</sub>	High-level output current		-32	mA
I <sub>OL</sub>	Low-level output current		64	mA
Δt/Δv	Input transition rise or fall rate	0	5	ns/V
T <sub>amb</sub>	Operating free-air temperature range	-40	+85	°C

## DC ELECTRICAL CHARACTERISTICS

SYMBOL	PARAMETER	TEST CONDITIONS	LIMITS					UNIT
			T <sub>amb</sub> = +25°C			T <sub>amb</sub> = -40°C to +85°C		
			Min	Typ	Max	Min	Max	
V <sub>IK</sub>	Input clamp voltage	V <sub>CC</sub> = 4.5V; I <sub>IK</sub> = -18mA		-0.9	-1.2		-1.2	V
V <sub>OH</sub>	High-level output voltage	V <sub>CC</sub> = 4.5V; I <sub>OH</sub> = -3mA; V <sub>I</sub> = V <sub>IL</sub> or V <sub>IH</sub>	2.5	2.9		2.5		V
		V <sub>CC</sub> = 5.0V; I <sub>OH</sub> = -3mA; V <sub>I</sub> = V <sub>IL</sub> or V <sub>IH</sub>	3.0	3.4		3.0		V
		V <sub>CC</sub> = 4.5V; I <sub>OH</sub> = -32mA; V <sub>I</sub> = V <sub>IL</sub> or V <sub>IH</sub>	2.0	2.4		2.0		V
V <sub>OL</sub>	Low-level output voltage	V <sub>CC</sub> = 4.5V; I <sub>OL</sub> = 64mA; V <sub>I</sub> = V <sub>IL</sub> or V <sub>IH</sub>		0.42	0.55		0.55	V
I <sub>I</sub>	Input leakage current	Control pins V <sub>CC</sub> = 5.5V; V <sub>I</sub> = GND or 5.5V		±0.01	±1.0		±1.0	μA
		Data pins V <sub>CC</sub> = 5.5V; V <sub>I</sub> = GND or 5.5V		±5	±100		±100	μA
I <sub>OFF</sub>	Power-off leakage current	V <sub>CC</sub> = 0.0V; V <sub>I</sub> or V <sub>O</sub> ≤ 4.5V		±5.0	±100		±100	μA
I <sub>PU</sub> /I <sub>PD</sub>	Power-up/down 3-State output current <sup>3</sup>	V <sub>CC</sub> = 2.0V; V <sub>O</sub> = 0.5V; V <sub>I</sub> = GND or V <sub>CC</sub> ; V <sub>OE</sub> = Don't care		±5.0	±50		±50	μA
I <sub>IH</sub> + I <sub>OZH</sub>	3-State output High current	V <sub>CC</sub> = 5.5V; V <sub>O</sub> = 2.7V; V <sub>I</sub> = V <sub>IL</sub> or V <sub>IH</sub>		5.0	50		50	μA
I <sub>IL</sub> + I <sub>OZL</sub>	3-State output Low current	V <sub>CC</sub> = 5.5V; V <sub>O</sub> = 0.5V; V <sub>I</sub> = V <sub>IL</sub> or V <sub>IH</sub>		-5.0	-50		-50	μA
I <sub>CEx</sub>	Output high leakage current	V <sub>CC</sub> = 5.5V; V <sub>O</sub> = 5.5V; V <sub>I</sub> = GND or V <sub>CC</sub>		5.0	50		50	μA
I <sub>O</sub>	Output current <sup>1</sup>	V <sub>CC</sub> = 5.5V; V <sub>O</sub> = 2.5V	-40	-100	-180	-40	-180	mA
I <sub>CCH</sub>	Quiescent supply current	V <sub>CC</sub> = 5.5V; Outputs High, V <sub>I</sub> = GND or V <sub>CC</sub>		50	250		250	μA
I <sub>CCL</sub>		V <sub>CC</sub> = 5.5V; Outputs Low, V <sub>I</sub> = GND or V <sub>CC</sub>		24	30		30	mA
I <sub>CCZ</sub>		V <sub>CC</sub> = 5.5V; Outputs 3-State; V <sub>I</sub> = GND or V <sub>CC</sub>		50	250		250	μA
ΔI <sub>CC</sub>	Additional supply current per input pin <sup>2</sup>	Outputs enabled, one input at 3.4V, other inputs at V <sub>CC</sub> or GND; V <sub>CC</sub> = 5.5V		0.5	1.5		1.5	mA
		Outputs 3-State, one data input at 3.4V, other inputs at V <sub>CC</sub> or GND; V <sub>CC</sub> = 5.5V		50	250		250	μA
		Outputs 3-State, one enable input at 3.4V, other inputs at V <sub>CC</sub> or GND; V <sub>CC</sub> = 5.5V		0.5	1.5		1.5	mA

## NOTES:

- Not more than one output should be tested at a time, and the duration of the test should not exceed one second.
- This is the increase in supply current for each input at 3.4V.
- This parameter is valid for any V<sub>CC</sub> between 0V and 2.1V with a transition time of up to 10msec. For V<sub>CC</sub> = 2.1V to V<sub>CC</sub> = 5V ± 10%, a transition time of up to 100μsec is permitted.

# Octal transceiver with direction pin (3-State)

74ABT245

## AC CHARACTERISTICS

GND = 0V;  $t_R = t_F = 2.5\text{ns}$ ;  $C_L = 50\text{pF}$ ,  $R_L = 500\Omega$

SYMBOL	PARAMETER	WAVEFORM	LIMITS					UNIT
			$T_{\text{amb}} = +25^\circ\text{C}$ $V_{\text{CC}} = +5.0\text{V}$			$T_{\text{amb}} = -40^\circ\text{C to } +85^\circ\text{C}$ $V_{\text{CC}} = +5.0\text{V} \pm 0.5\text{V}$		
			Min	Typ	Max	Min	Max	
$t_{\text{PLH}}$ $t_{\text{PHL}}$	Propagation delay An to Bn or Bn to An	1	1.0	2.2	4.1	1.0	4.6	ns
$t_{\text{PZH}}$ $t_{\text{PZL}}$	Output enable time to High and Low level	2	1.3	3.0	4.8	1.3	5.3	ns
$t_{\text{PHZ}}$ $t_{\text{PLZ}}$	Output disable time from High and Low Level	2	1.0	4.7	6.2	1.0	7.2	ns

## AC WAVEFORMS

$V_M = 1.5\text{V}$ ,  $V_{\text{IN}} = \text{GND to } 3.0\text{V}$

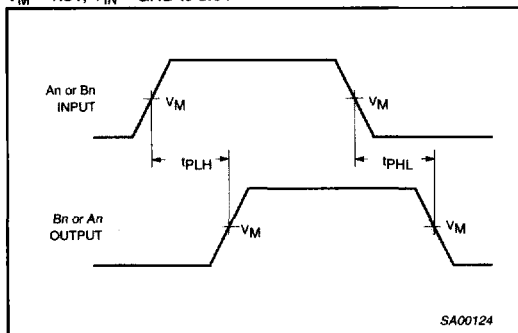

Waveform 1. Waveforms Showing the Input to Output Propagation Delays

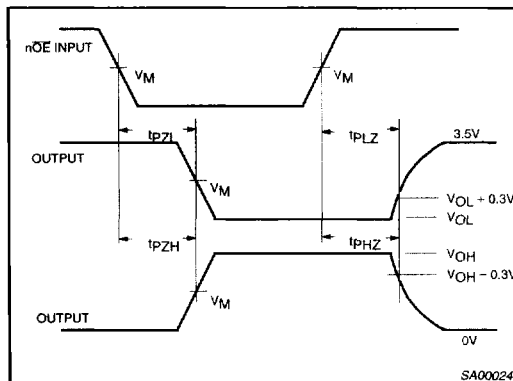

Waveform 2. Waveforms Showing the 3-State Output Enable and Disable Times

Octal transceiver with direction pin (3-State)

74ABT245

TEST CIRCUIT AND WAVEFORMS

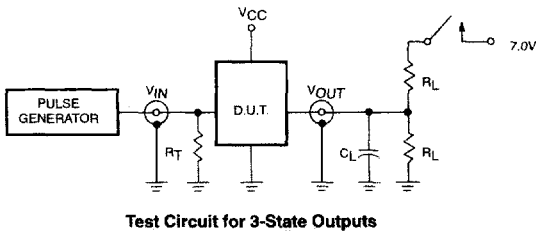

Test Circuit for 3-State Outputs

SWITCH POSITION

TEST	SWITCH
$t_{pLZ}$	closed
$t_{pZL}$	closed
All other	open

DEFINITIONS

$R_L$  = Load resistor; see AC CHARACTERISTICS for value.

$C_L$  = Load capacitance includes jig and probe capacitance; see AC CHARACTERISTICS for value.

$R_T$  = Termination resistance should be equal to  $Z_{OUT}$  of pulse generators.

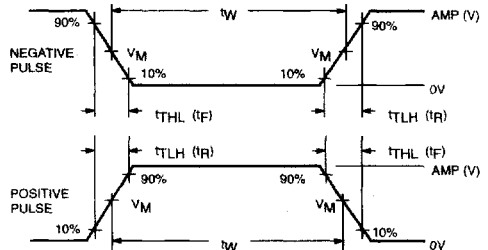

$V_M = 1.5V$

Input Pulse Definition

FAMILY	INPUT PULSE REQUIREMENTS				
	Amplitude	Rep. Rate	$t_W$	$t_R$	$t_F$
74ABT	3.0V	1MHz	500ns	2.5ns	2.5ns

SA00012