

# 54/7448 54LS/74LS48

## BCD TO 7-SEGMENT DECODER

**DESCRIPTION** — The '48 translates four lines of BCD (8421) input data into the 7-segment numeral code and provides seven corresponding outputs having pull-up resistors, as opposed to totem pole pull-ups. These outputs can serve as logic signals, with a HIGH output corresponding to a lighted lamp segment, or can provide a 1.3 mA base current to npn lamp driver transistors. Auxiliary inputs provide lamp test, blanking and cascadable zero-suppression functions.

The '48 decodes the input data in the pattern indicated in the Truth Table and the segment identification illustration. For a detailed description of the blanking, lamp test and zero-suppression functions refer to the '46A data sheet, but note that the segment output states of the '48 are the logical inverse of those of the '46A. Also see the 'LS248 data sheet.

**ORDERING CODE:** See Section 9

PKGS	PIN OUT	COMMERCIAL GRADE	MILITARY GRADE	PKG TYPE
		$V_{CC} = +5.0\text{ V} \pm 5\%$ , $T_A = 0^\circ\text{C to } +70^\circ\text{C}$	$V_{CC} = +5.0\text{ V} \pm 10\%$ , $T_A = -55^\circ\text{C to } +125^\circ\text{C}$	
Plastic DIP (P)	A	7448PC, 74LS48PC		9B
Ceramic DIP (D)	A	7448DC, 74LS48DC	5448DM, 54LS48DM	7B
Flatpak (F)	A	7448FC, 74LS48FC	5448FM, 54LS48FM	4L

### CONNECTION DIAGRAM PINOUT A

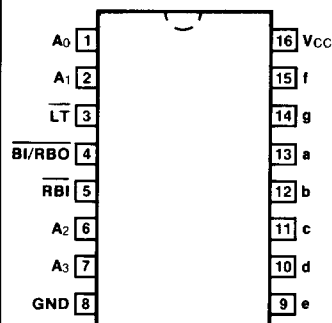

### LOGIC SYMBOL

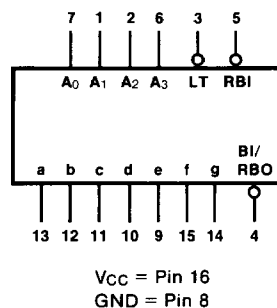

**INPUT LOADING/FAN-OUT:** See Section 3 for U.L. definitions

PIN NAMES	DESCRIPTION	54/74 (U.L.) HIGH/LOW	54/74LS (U.L.) HIGH/LOW
$A_0 - A_3$	BCD Inputs	1.0/1.0	0.5/0.25
RBI	Ripple Blanking Input (Active LOW)	1.0/1.0	0.5/0.25
LT	Lamp Test Input (Active LOW)	1.0/1.0	0.5/0.25
BI/RBO	Blanking Input (Active LOW) or Ripple Blanking Output (Active LOW)	-/2.5 5.0/5.0	-/0.75 1.25/2.0 (1.0)
a - g	Segment Outputs (Active HIGH)	10/4.0	2.5/3.75 (1.25)

## NUMERICAL DESIGNATIONS — RESULTANT DISPLAYS

0	1	2	3	4	5	6	7	8	9	.	—	U	E		
0	1	2	3	4	5	6	7	8	9	10	11	12	13	14	15

## TRUTH TABLE

DECIMAL OR FUNCTION	INPUTS						OUTPUTS							NOTE
	$\overline{\text{LT}}$	$\overline{\text{RBI}}$	A <sub>3</sub>	A <sub>2</sub>	A <sub>1</sub>	A <sub>0</sub>	$\overline{\text{BI/RBO}}$	a	b	c	d	e	f	
0	H	H	L	L	L	L	H	H	H	H	H	H	L	
1	H	X	L	L	L	H	H	L	H	H	L	L	L	1
2	H	X	L	L	H	L	H	H	H	L	H	L	H	1
3	H	X	L	L	H	H	H	H	H	H	H	L	H	
4	H	X	L	H	L	L	H	L	H	H	L	L	H	
5	H	X	L	H	L	H	H	H	L	H	H	L	H	
6	H	X	L	H	H	L	H	L	L	H	H	H	H	
7	H	X	L	H	H	H	H	H	H	H	L	L	L	
8	H	X	H	L	L	L	H	H	H	H	H	H	H	
9	H	X	H	L	L	H	H	H	H	H	L	L	H	
10	H	X	H	L	H	L	H	L	L	L	H	H	L	
11	H	X	H	L	H	H	H	L	L	H	H	L	H	
12	H	X	H	H	L	L	H	L	H	L	L	L	H	
13	H	X	H	H	L	H	H	H	L	L	H	L	H	
14	H	X	H	H	H	L	H	L	L	L	H	H	H	
15	H	X	H	H	H	H	H	L	L	L	L	L	L	
$\overline{\text{BI}}$	X	X	X	X	X	X	L	L	L	L	L	L	L	2
$\overline{\text{RBI}}$	H	L	L	L	L	L	L	L	L	L	L	L	L	3
$\overline{\text{LT}}$	L	X	X	X	X	X	H	H	H	H	H	H	H	4

## NOTES:

- (1)  $\overline{\text{BI/RBO}}$  is wired-AND logic serving as blanking input ( $\overline{\text{BI}}$ ) and/or ripple-blanking output ( $\overline{\text{RBO}}$ ). The blanking out ( $\overline{\text{BI}}$ ) must be open or held at a HIGH level when output functions 0 through 15 are desired, and ripple-blanking input ( $\overline{\text{RBI}}$ ) must be open or at a HIGH level if blanking of a decimal 0 is not desired. X = input may be HIGH or LOW.
- (2) When a LOW level is applied to the blanking input (forced condition) all segment outputs go to a LOW level, regardless of the state of any other input condition.
- (3) When ripple-blanking input ( $\overline{\text{RBI}}$ ) and inputs A<sub>0</sub>, A<sub>1</sub>, A<sub>2</sub>, and A<sub>3</sub> are at LOW level, with the lamp test input at HIGH level, all segment outputs go to a LOW level and the ripple-blanking output ( $\overline{\text{RBO}}$ ) goes to a LOW level (response condition).
- (4) When the blanking input/ripple-blanking output ( $\overline{\text{BI/RBO}}$ ) is open or held at a HIGH level, and a LOW level is applied to lamp test input, all segment outputs go to a HIGH level.

LOGIC DIAGRAM

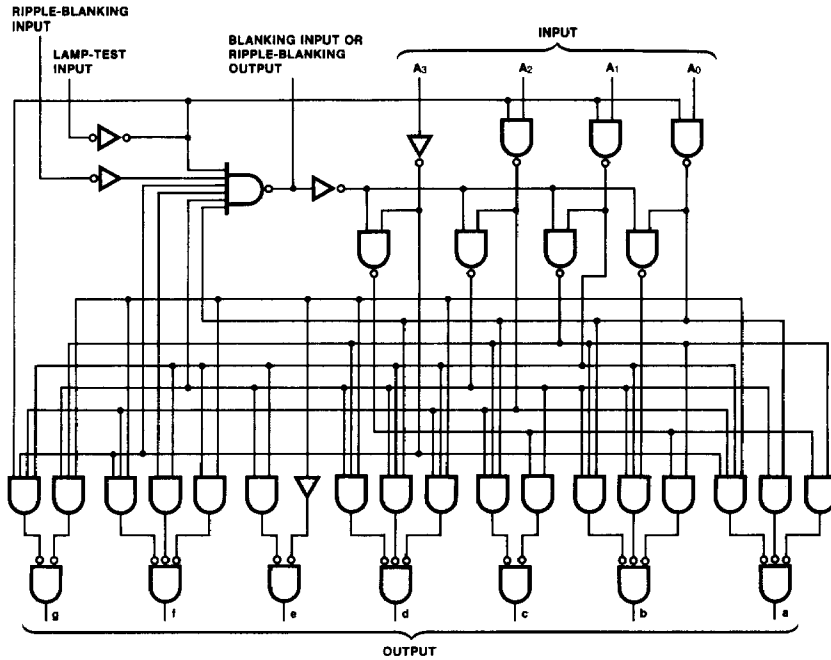

DC CHARACTERISTICS OVER OPERATING TEMPERATURE RANGE (unless otherwise specified)

SYMBOL	PARAMETER	54/74		54/74LS		UNITS	CONDITIONS
		Min	Max	Min	Max		
IOH	Output HIGH Current at a—g	-1.3		-1.3		mA	VCC = Min, VOUT = 0.85 V
IOS	Output Short Circuit Current at BI/RBO	-4.0		-0.3	-2.0	mA	VCC = Max, VOUT = 0 V
ICC	Power Supply Current	XM	76	38		mA	VCC = Max All Inputs = 4.5 V
		XC	90	38			

AC CHARACTERISTICS: VCC = +5.0 V, TA = +25°C (See Section 3 for waveforms and load configurations)

SYMBOL	PARAMETER	54/74		54/74LS		UNITS	CONDITIONS
		CL = 15 pF RL = 1 kΩ		CL = 15 pF			
		Min	Max	Min	Max		
tPLH	Propagation Delay	100		100		ns	Figs. 3-1, 3-20
tPHL	An to a—g	100		100			
tPLH	Propagation Delay	100		100		ns	Figs. 3-1, 3-5 LT = HIGH, A0—A3 = HIGH
tPHL	RBI to a—f	100		100			