

# .100" x .100" Low Profile Header

Straight, 4 Wall, High Temp

2500 Series

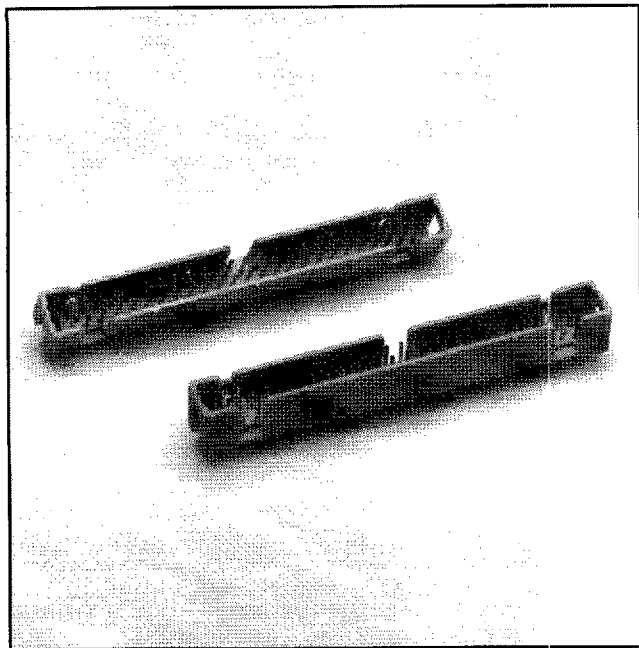

- Low profile, space saving design
- Socket compatibility for current design validation
- Center slot polarization prevents mis-insertions and reduces insertion time
- Dual slot polarization means broader compatibility with competitive polarization designs
- Optional retainer clamp for locking sockets in place and increasing connection reliability in vibration-prone environments
- High temperature

TS-0486-06  
Sheet 1 of 2

## Physical

### Insulation

Material: Glass Filled Polyester (PBT)  
Flammability: UL 94V-0  
Color: Beige  
Marking: 3M Logo, and Orientation Triangle

### Contact

Material: Phosphor Bronze (C510)  
Plating  
Underplate: 100  $\mu$ " [ 2.54  $\mu$ m ] Nickel — QQ-N-290, Class 2  
Wiping Area: Gold — MIL-G-45204, Type II, Grade C  
Solder Tails: 200  $\mu$ " [ 5.08  $\mu$ m ] 60/40 Tin Lead — MIL-P-81728

## Electrical

Current Rating: 2 A  
Insulation Resistance:  $>1 \times 10^9 \Omega$  at 500 Vdc  
Withstanding Voltage: 1000 Vrms at Sea Level

## Environmental

Temperature Rating:  $-55^\circ\text{C}$  to  $+105^\circ\text{C}$   
Processing: Maximum  $235^\circ\text{C}$ , with 90 Seconds over  $215^\circ\text{C}$

UL File No.: E68080  
CSA File No.: LR 40971

3M Electronic Products Division

6801 River Place Blvd.  
Austin, TX 78726-9000

■ 9005413 0000183 T42 ■

# .100" x .100" Low Profile Header

Straight, 4 Wall, High Temp

2500 Series

3M Part No. Suffix	Tail	Dim E	Dim F			Dim G
-60X2	2	.112 [ 2.84 ]	.0245 ± .0005 [ 0.622 ]	with	.028 ± .001 [ 0.71 ]	Diagonals .035 ± .003 [ 0.89 ] (Note 2)
-6003	3	.155 [ 3.94 ]	.0245 ± .0005 [ 0.622 ]	with	.028 ± .001 [ 0.71 ]	Diagonals .035 ± .003 [ 0.89 ]

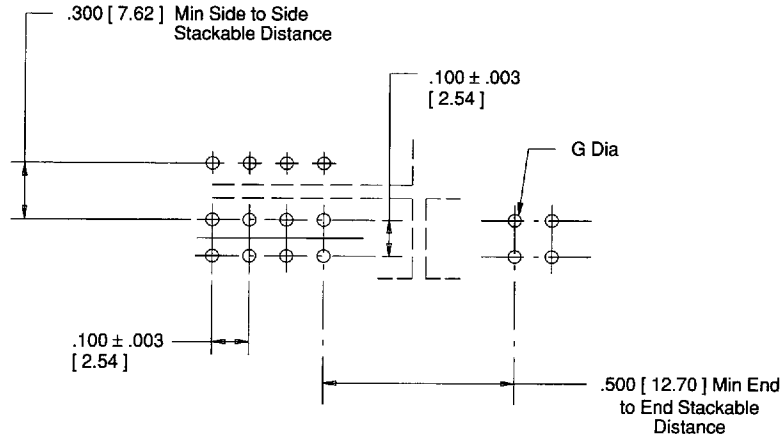

Recommended P.C. Board Hold Pattern (Shown for Mounting Side of Board)

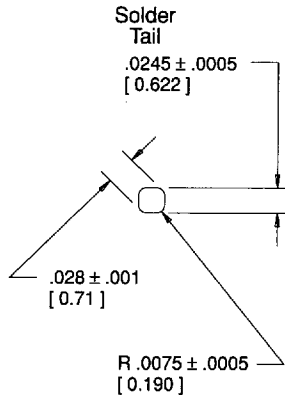

Pin Cross Section

## Ordering Information

N 25XX-60XX-XX

Pin Quantity:  
See Table

- Tail
- 02 = Solder Tails for .062 [ 1.57 ] Thick Board.
  - K2 = Kinked Solder Tails for .062 [ 1.57 ] Thick Board.
  - 03 = Solder Tails for .094 to .125 [ 2.39 to 3.18 ] Thick Board.

Mating Plating Thickness:  
UG = 10 μ" [ 0.25 μm ]  
UB = 30 μ" [ 0.76 μm ]

Sheet 2 of 3

TS-0486-06

# .100" x .100" Low Profile Header

Straight, 4 Wall, High Temp

2500 Series

PIN QTY	DIM A		DIM B		POLARIZING NOTCHES PROVIDED
10	0.79	[20.0]	0.70	[17.8]	BC
14	0.99	[25.1]	0.90	[22.8]	BCDE
16	1.09	[27.6]	1.00	[25.4]	ABCDE
20	1.29	[32.7]	1.20	[30.4]	ABCDE
24	1.49	[37.8]	1.40	[35.5]	ABCDE
26	1.59	[40.3]	1.50	[38.1]	ABCDE
30	1.79	[45.4]	1.70	[43.2]	ABCDE
34	1.99	[50.5]	1.90	[48.2]	ABCDE
40	2.29	[58.1]	2.20	[55.9]	ABCDE
50	2.79	[70.8]	2.70	[68.6]	ABCDE
60	3.29	[83.5]	3.20	[81.3]	ABCDE

Sheet 3 of 3

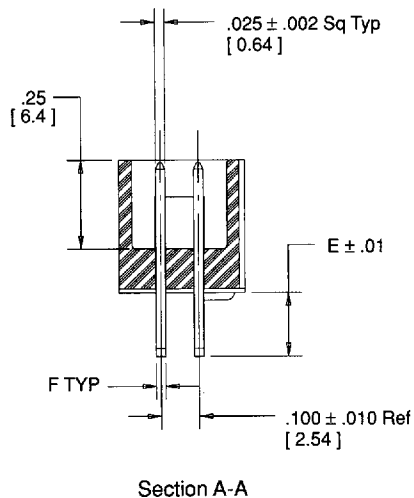
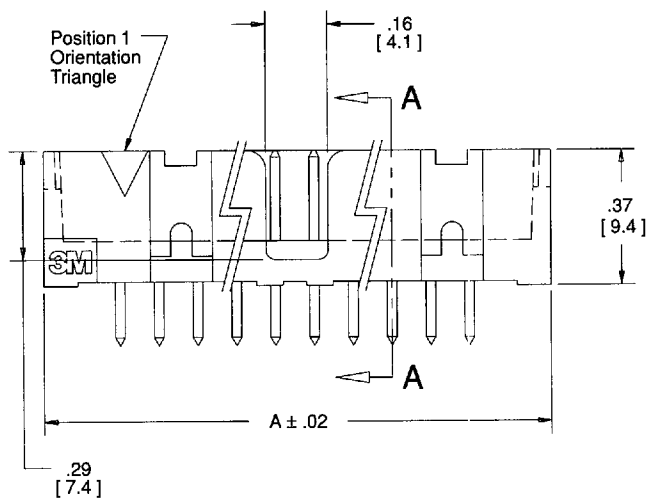
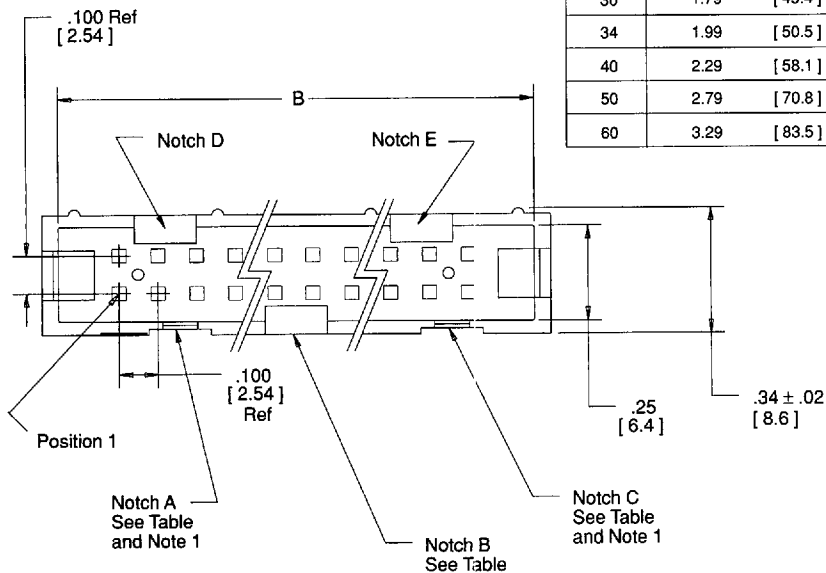

TS-0486-06

Inch  
[mm]

Tolerance Unless Noted			
	.0	.00	.000
Inch	±.1	±.01	±.005

Notes :

- Notches "A" and "C" will accommodate 3M Polarizing Keys. (Part number 3518 or M3518)
- The recommended PCB hole size for the kinked tail positions on the .112" solder tail connector is .035" ± .002.

[ ] Dimensions for Reference Only