

MICRO

MSB51DA-X
(MSB51DA)
 ULTRA HIGH
 BRIGHTNESS
 RED LED LAMP

DESCRIPTION

MSB51DA-X is an ultra high brightness output red GaAlAs LED lamp encapsulated in a 5mm diameter red diffused lens with an optimum viewing angle. 6 brightness grouping is provided for customer's selection.

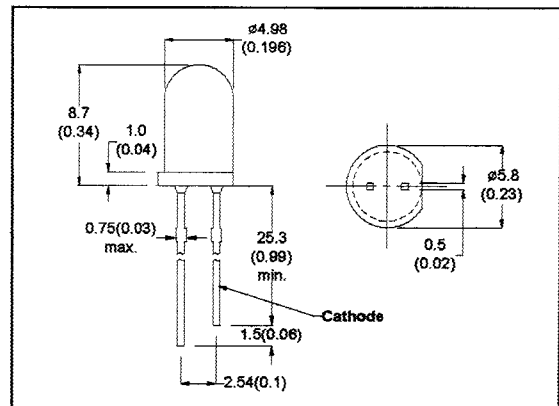

- All Dimension in mm (inch)
- No Scale
- Tol: +/- 0.3mm

ABSOLUTE MAXIMUM RATINGS

Power Dissipation @ Ta=25°C	100mW
Forward Current, DC (IF)	40mA
Reverse Voltage	5V
Operating & Storage Temperature Range	-55 to +100°C
Lead Soldering Temperature (1/16" from body)	260°C for 5 sec.

ELECTRO-OPTICAL CHARACTERISTICS (Ta=25°C)

PARAMETER	SYMBOL	MIN	TYP	MAX	UNIT	CONDITIONS
Forward Voltage	VF		1.8	2.4	V	IF=20mA
Reverse Breakdown Voltage	BVR	5			V	IR=100μA
Luminous Intensity	IV				mcd	IF=20mA
		20	35			
MSB51DA &		30	60		mcd	IF=20mA
		80	120		mcd	IF=20mA
		130	200		mcd	IF=20mA
		180	250		mcd	IF=20mA
		250	350		mcd	IF=20mA
Peak Wavelength	λp		660		nm	IF=20mA
Spectral Line Half Width	Δλ		20		nm	IF=20mA
Viewing Angle	2θ 1/2		40		degree	IF=20mA

MSB51DA-1, -2, -3, -4&-5

