

54ACTQ/74ACTQ32

Quiet Series Quad 2-Input OR Gate

General Description

The 'ACTQ32 contains four, 2-input OR gates and utilizes NSC Quiet Series technology to guarantee quiet output switching and improved dynamic threshold performance. FACT Quiet Series™ features GTOT™ output control and undershoot corrector in addition to a split ground bus for superior AC MOS performance.

Features

- I_{CC} reduced by 50%
- Guaranteed simultaneous switching noise level and dynamic threshold performance
- Improved latch-up immunity
- Minimum 4 kV ESD protection
- Outputs source/sink 24 mA
- 'ACTQ32 has TTL-compatible inputs
- Standard Military Drawing (SMD)
 - 'ACTQ32: 5962-89736

Ordering Code: See Section 8

Logic Symbol

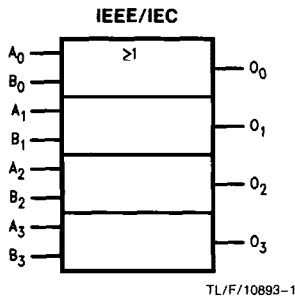

Connection Diagrams

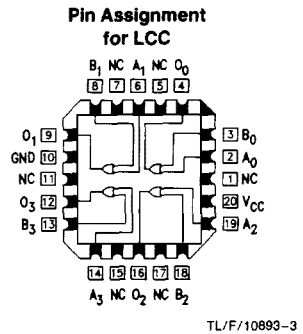
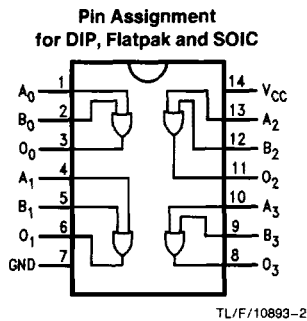

Pin Names	Description
A _n , B _n	Inputs
O _n	Outputs

Absolute Maximum Ratings (Note 1)

If Military/Aerospace specified devices are required, please contact the National Semiconductor Sales Office/Distributors for availability and specifications.

Supply Voltage (V_{CC})	-0.5V to +7.0V
DC Input Diode Current (I_{IK})	
$V_I = -0.5V$	-20 mA
$V_I = V_{CC} + 0.5V$	+20 mA
DC Input Voltage (V_I)	-0.5V to $V_{CC} + 0.5V$
DC Output Diode Current (I_{OK})	
$V_O = -0.5V$	-20 mA
$V_O = V_{CC} + 0.5V$	+20 mA
DC Output Voltage (V_O)	-0.5V to $V_{CC} + 0.5V$
DC Output Source or Sink Current (I_O)	± 50 mA
DC V_{CC} or Ground Current per Output Pin (I_{CC} or I_{GND})	± 50 mA
Storage Temperature (T_{STG})	-65°C to +150°C
DC Latch-up Source or Sink Current	± 300 mA
Junction Temperature (T_J)	
CDIP	175°C
PDIP	140°C

Note 1: Absolute maximum ratings are those values beyond which damage to the device may occur. The databook specifications should be met, without exception, to ensure that the system design is reliable over its power supply, temperature, and output/input loading variables. National does not recommend operation of FACT™ circuits outside databook specifications.

Recommended Operating Conditions (Note 2)

Supply Voltage (V_{CC})	4.5V to 5.5V
'ACTQ	
Input Voltage (V_I)	0V to V_{CC}
Output Voltage (V_O)	0V to V_{CC}
Operating Temperature (T_A)	
74ACTQ	-40°C to +85°C
54ACTQ	-55°C to +125°C
Minimum Input Edge Rate ($\Delta V/\Delta t$)	
'ACTQ Devices	125 mV/ns
V_{IN} from 0.8V to 2.0V	
V_{CC} @ 4.5V, 5.5V	

Note 2: All commercial packaging is not recommended for applications requiring greater than 2000 temperature cycles from -40°C to +125°C.

DC Characteristics for 'ACTQ Family Devices

Symbol	Parameter	V_{CC} (V)	74ACTQ		54ACTQ		74ACTQ		Units	Conditions
			$T_A = +25^\circ\text{C}$		$T_A = -55^\circ\text{C to } +125^\circ\text{C}$		$T_A = -40^\circ\text{C to } +85^\circ\text{C}$			
			Typ	Guaranteed Limits						
V_{IH}	Minimum High Level Input Voltage	4.5	1.5	2.0	2.0	2.0	2.0	2.0	V	$V_{OUT} = 0.1V$ or $V_{CC} - 0.1V$
		5.5	1.5	2.0	2.0	2.0	2.0	2.0		
V_{IL}	Maximum Low Level Input Voltage	4.5	1.5	0.8	0.8	0.8	0.8	0.8	V	$V_{OUT} = 0.1V$ or $V_{CC} - 0.1V$
		5.5	1.5	0.8	0.8	0.8	0.8	0.8		
V_{OH}	Minimum High Level Output Voltage	4.5	4.49	4.4	4.4	4.4	4.4	4.4	V	$I_{OUT} = -50 \mu\text{A}$
		5.5	5.49	5.4	5.4	5.4	5.4	5.4		
		4.5		3.86	3.70	3.76			V	$*V_{IN} = V_{IL}$ or V_{IH} -24 mA I_{OH} -24 mA
		5.5		4.86	4.70	4.76				
V_{OL}	Maximum Low Level Output Voltage	4.5	0.001	0.1	0.1	0.1	0.1	0.1	V	$I_{OUT} = 50 \mu\text{A}$
		5.5	0.001	0.1	0.1	0.1	0.1	0.1		
		4.5		0.36	0.50	0.44			V	$*V_{IN} = V_{IL}$ or V_{IH} 24 mA I_{OL} 24 mA
		5.5		0.36	0.50	0.44	0.44	0.44		
I_{IN}	Maximum Input Leakage Current	5.5		± 0.1	± 1.0	± 1.0	± 1.0	μA	$V_I = V_{CC}, \text{GND}$	

*All outputs loaded; thresholds on input associated with output under test.

DC Characteristics for 'ACTQ Family Devices (Continued)

Symbol	Parameter	V _{CC} (V)	74ACTQ		54ACTQ		74ACTQ		Units	Conditions
			T _A = +25°C		T _A = -55°C to +125°C		T _A = -40°C to +85°C			
			Typ	Guaranteed Limits						
I _{CC} T	Maximum I _{CC} /Input	5.5	0.6			1.6		1.5	mA	V _I = V _{CC} - 2.1V
I _{OLD}	†Minimum Dynamic Output Current	5.5				50		75	mA	V _{OLD} = 1.65V Max
I _{OHD}		5.5				-50		-75	mA	V _{OHD} = 3.85V Min
I _{CC}	Maximum Quiescent Supply Current	5.5		2.0		40.0		20.0	μA	V _{IN} = V _{CC} or GND (Note 1)
V _{OLP}	Quiet Output Maximum Dynamic V _{OL}	5.0	1.1	1.5					V	Figures 2-12, 13 (Notes 2, 3)
V _{OLV}	Quiet Output Minimum Dynamic V _{OL}	5.0	-0.6	-1.2					V	Figures 2-12, 13 (Notes 2, 3)
V _{IHD}	Minimum High Level Dynamic Input Voltage	5.0	1.9	2.2					V	(Notes 2, 4)
V _{ILD}	Maximum Low Level Dynamic Input Voltage	5.0	1.2	0.8					V	(Notes 2, 4)

†Maximum test duration 2.0 ms, one output loaded at a time.

Note 1: I_{CC} for 54ACTQ @ 25°C is identical to 74ACTQ @ 25°C.

Note 2: Plastic DIP package.

Note 3: Max number of outputs defined as (n). Data inputs are 0V to 3V. One output @ GND.

Note 4: Max number of data inputs (n) switching. (n-1) inputs switching 0V to 3V ('ACTQ). Input-under-test switching: 3V to threshold (V_{ILD}), 0V to threshold (V_{IHD}), f = 1 MHz.

AC Electrical Characteristics: See Section 2 for Waveforms

Symbol	Parameter	V _{CC} * (V)	74ACTQ			54ACTQ		74ACTQ		Units	Fig. No.
			T _A = +25°C C _L = 50 pF			T _A = -55°C to +125°C C _L = 50 pF		T _A = -40°C to +85°C C _L = 50 pF			
			Min	Typ	Max	Min	Max	Min	Max		
t _{PLH}	Propagation Delay Data to Output	5.0	2.5	6.0	6.5	1.5	7.5	2.5	7.0	ns	2-3, 4
t _{PHL}	Propagation Delay Data to Output	5.0	2.5	6.0	6.5	1.5	7.5	2.5	7.0	ns	2-3, 4
t _{OSSL} , t _{OSLH}	Output to Output Skew**	5.0		0.5	1.0				1.0	ns	

*Voltage Range 5.0 is 5.0V ±0.5V

**Skew is defined as the absolute value of the difference between the actual propagation delay for any two separate outputs of the same device. The specification applies to any outputs switching in the same direction, either HIGH to LOW (t_{OSSL}) or LOW to HIGH (t_{OSLH}). Parameter guaranteed by design.

Capacitance

Symbol	Parameter	Typ	Units	Conditions
C _{IN}	Input Capacitance	4.5	pF	V _{CC} = OPEN
C _{PD}	Power Dissipation Capacitance	68	pF	V _{CC} = 5.0V