



NATL SEMICON (LINEAR)

T-79-07-10

LM118/LM218/LM318

## LM118/LM218/LM318 Operational Amplifiers

### General Description

The LM118 series are precision high speed operational amplifiers designed for applications requiring wide bandwidth and high slew rate. They feature a factor of ten increase in speed over general purpose devices without sacrificing DC performance.

The LM118 series has internal unity gain frequency compensation. This considerably simplifies its application since no external components are necessary for operation. However, unlike most internally compensated amplifiers, external frequency compensation may be added for optimum performance. For inverting applications, feedforward compensation will boost the slew rate to over  $150V/\mu s$  and almost double the bandwidth. Overcompensation can be used with the amplifier for greater stability when maximum bandwidth is not needed. Further, a single capacitor can be added to reduce the 0.1% settling time to under  $1 \mu s$ .

The high speed and fast settling time of these op amps make them useful in A/D converters, oscillators, active fil-

ters, sample and hold circuits, or general purpose amplifiers. These devices are easy to apply and offer an order of magnitude better AC performance than industry standards such as the LM709.

The LM218 is identical to the LM118 except that the LM218 has its performance specified over a  $-25^{\circ}C$  to  $+85^{\circ}C$  temperature range. The LM318 is specified from  $0^{\circ}C$  to  $+70^{\circ}C$ .

### Features

- 15 MHz small signal bandwidth
- Guaranteed  $50V/\mu s$  slew rate
- Maximum bias current of 250 nA
- Operates from supplies of  $\pm 5V$  to  $\pm 20V$
- Internal frequency compensation
- Input and output overload protected
- Pin compatible with general purpose op amps

### Connection Diagrams

Dual-In-Line Package

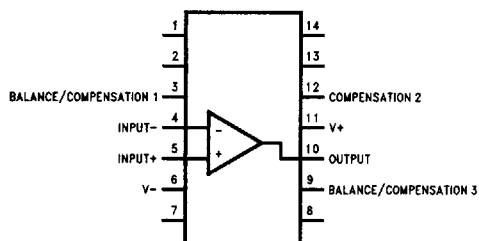

Top View

Order Number LM118J/883\*  
See NS Package Number J14A

TL/H/7766-24

Dual-In-Line Package

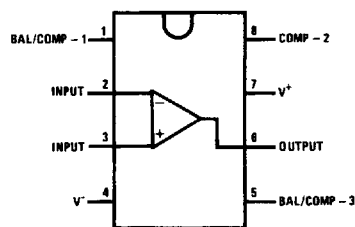

Top View

Order Number LM118J-8, LM118J-8/883\*  
LM318J-8, LM318M or LM318N  
See NS Package Number J08A, M08A or N08B

TL/H/7766-3

Metal Can Package\*\*

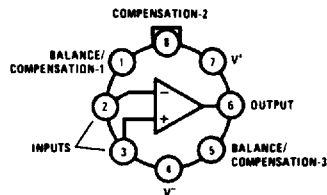

Top View

\*\*Pin connections shown on schematic diagram and typical applications are for TO-5 package.

Order Number LM118H, LM118H/883\*  
LM218H or LM318H  
See NS Package Number H08C

TL/H/7766-2

\*Available per JM38510/10107.

## Absolute Maximum Ratings

If Military/Aerospace specified devices are required, please contact the National Semiconductor Sales Office/Distributors for availability and specifications. (Note 6)

Supply Voltage	±20V
Power Dissipation (Note 1)	500 mW
Differential Input Current (Note 2)	±10 mA
Input Voltage (Note 3)	±15V
Output Short-Circuit Duration	Continuous

Operating Temperature Range	
LM118	-55°C to +125°C
LM218	-25°C to +85°C
LM318	0°C to +70°C
Storage Temperature Range	
	-65°C to +150°C
Lead Temperature (Soldering, 10 sec.)	
Hermetic Package	300°C
Plastic Package	260°C
Soldering Information	
Dual-In-Line Package	
Soldering (10 sec.)	260°C
Small Outline Package	
Vapor Phase (60 sec.)	215°C
Infrared (15 sec.)	220°C

See AN-450 "Surface Mounting Methods and Their Effect on Product Reliability" for other methods of soldering surface mount devices.

ESD Tolerance (Note 7) 2000V

NATL SEMICOND (LINEAR)

## Electrical Characteristics (Note 4)

Parameter	Conditions	LM118/LM218			LM318			Units
		Min	Typ	Max	Min	Typ	Max	
Input Offset Voltage	$T_A = 25^\circ\text{C}$		2	4		4	10	mV
Input Offset Current	$T_A = 25^\circ\text{C}$		6	50		30	200	nA
Input Bias Current	$T_A = 25^\circ\text{C}$		120	250		150	500	nA
Input Resistance	$T_A = 25^\circ\text{C}$	1	3		0.5	3		M $\Omega$
Supply Current	$T_A = 25^\circ\text{C}$		5	8		5	10	mA
Large Signal Voltage Gain	$T_A = 25^\circ\text{C}$ , $V_S = \pm 15\text{V}$ $V_{OUT} = \pm 10\text{V}$ , $R_L \geq 2\text{ k}\Omega$	50	200		25	200		V/mV
Slew Rate	$T_A = 25^\circ\text{C}$ , $V_S = \pm 15\text{V}$ , $A_V = 1$ (Note 5)	50	70		50	70		V/ $\mu\text{s}$
Small Signal Bandwidth	$T_A = 25^\circ\text{C}$ , $V_S = \pm 15\text{V}$		15			15		MHz
Input Offset Voltage				6			15	mV
Input Offset Current				100			300	nA
Input Bias Current				500			750	nA
Supply Current	$T_A = 125^\circ\text{C}$		4.5	7				mA
Large Signal Voltage Gain	$V_S = \pm 15\text{V}$ , $V_{OUT} = \pm 10\text{V}$ $R_L \geq 2\text{ k}\Omega$	25			20			V/mV
Output Voltage Swing	$V_S = \pm 15\text{V}$ , $R_L = 2\text{ k}\Omega$	±12	±13		±12	±13		V
Input Voltage Range	$V_S = \pm 15\text{V}$	±11.5			±11.5			V
Common-Mode Rejection Ratio		80	100		70	100		dB
Supply Voltage Rejection Ratio		70	80		65	80		dB

**Note 1:** The maximum junction temperature of the LM118 is 150°C, the LM218 is 110°C, and the LM318 is 110°C. For operating at elevated temperatures, devices in the H08 package must be derated based on a thermal resistance of 160°C/W, junction to ambient, or 20°C/W, junction to case. The thermal resistance of the dual-in-line package is 100°C/W, junction to ambient.

**Note 2:** The inputs are shunted with back-to-back diodes for overvoltage protection. Therefore, excessive current will flow if a differential input voltage in excess of 1V is applied between the inputs unless some limiting resistance is used.

**Note 3:** For supply voltages less than ±15V, the absolute maximum input voltage is equal to the supply voltage.

**Note 4:** These specifications apply for  $\pm 5\text{V} \leq V_S \leq \pm 20\text{V}$  and  $-55^\circ\text{C} \leq T_A \leq +125^\circ\text{C}$  (LM118),  $-25^\circ\text{C} \leq T_A \leq +85^\circ\text{C}$  (LM218), and  $0^\circ\text{C} \leq T_A \leq +70^\circ\text{C}$  (LM318). Also, power supplies must be bypassed with 0.1  $\mu\text{F}$  disc capacitors.

**Note 5:** Slew rate is tested with  $V_S = \pm 15\text{V}$ . The LM118 is in a unity-gain non-inverting configuration.  $V_{IN}$  is stepped from -7.5V to +7.5V and vice versa. The slew rates between -5.0V and +5.0V and vice versa are tested and guaranteed to exceed 50V/ $\mu\text{s}$ .

**Note 6:** Refer to RETS118X for LM118H and LM118J military specifications.

**Note 7:** Human body model, 1.5 k $\Omega$  in series with 100 pF.

# Typical Performance Characteristics LM118, LM218

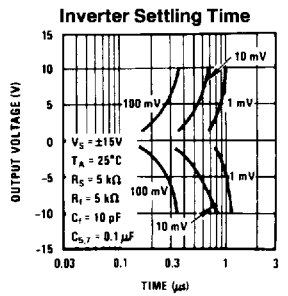
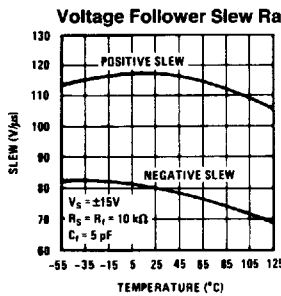
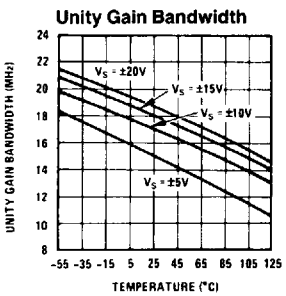
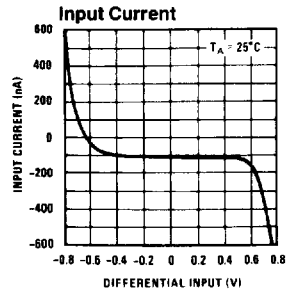
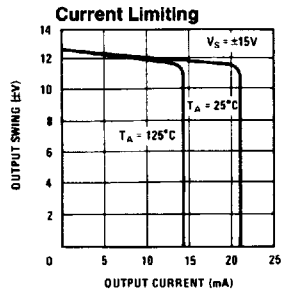
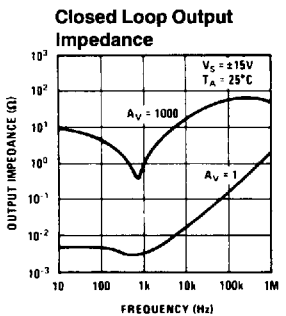
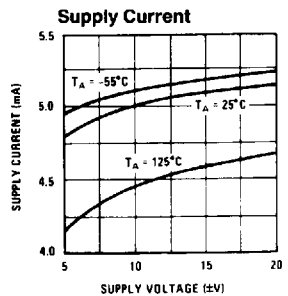
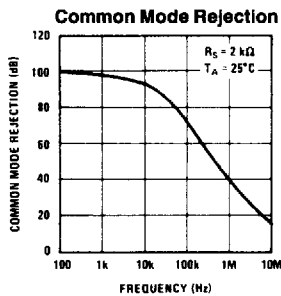
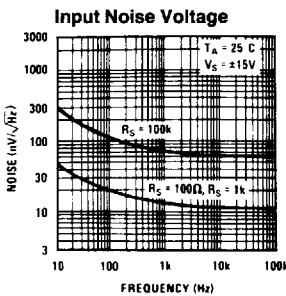
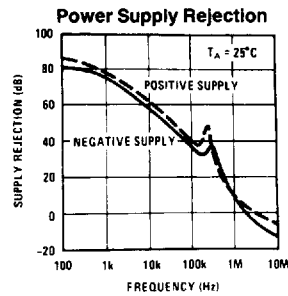
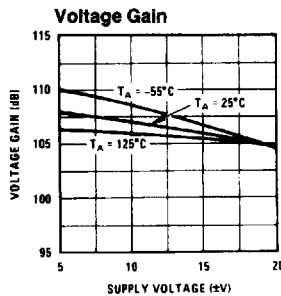
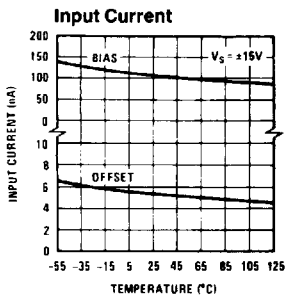

Typical Performance Characteristics LM118, LM218 (Continued)

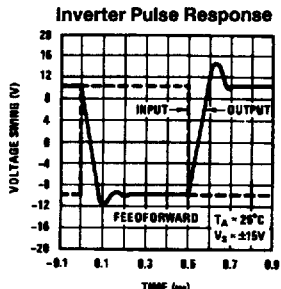
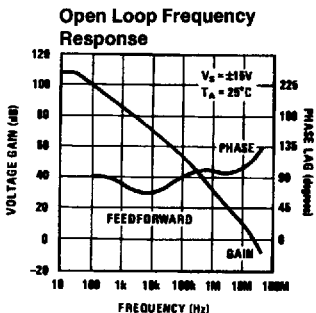
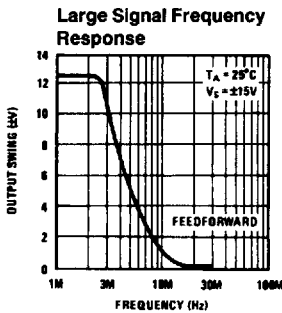
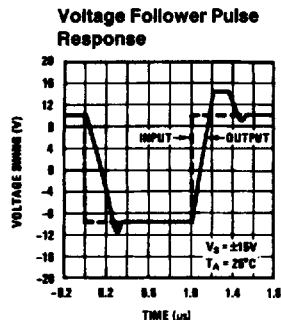
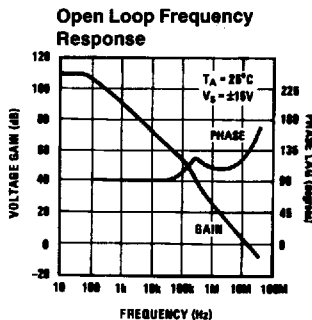
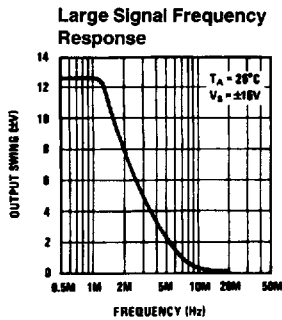

TL/H/7766-5

Typical Performance Characteristics LM318

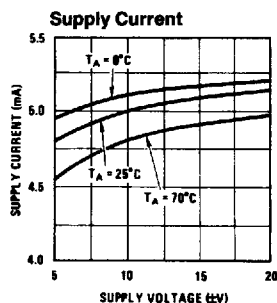
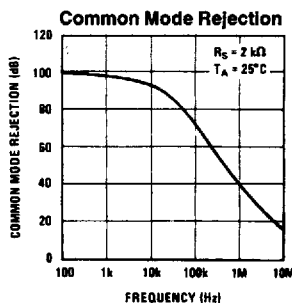
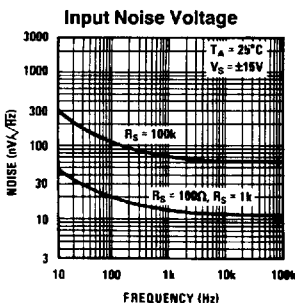
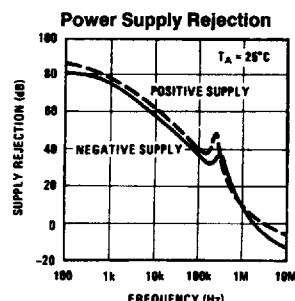
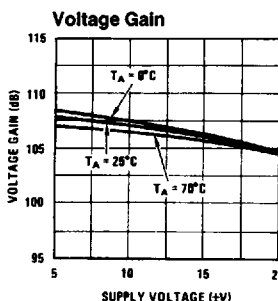
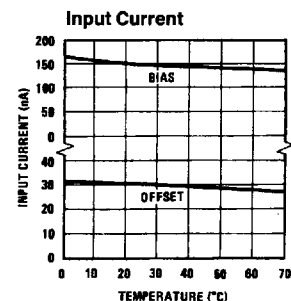

TL/H/7766-6

Typical Performance Characteristics LM318 (Continued)

Closed Loop Output Impedance

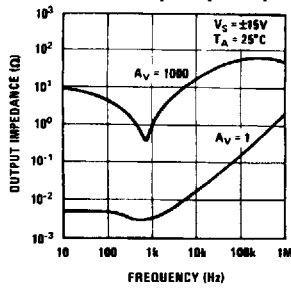

Current Limiting

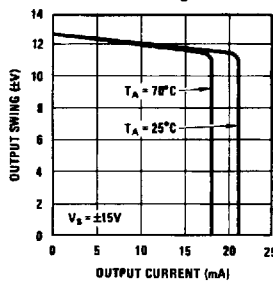

Input Current

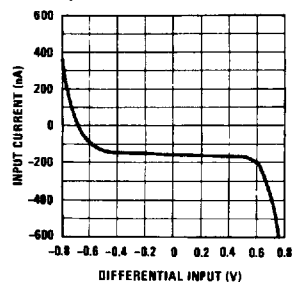

Unity Gain Bandwidth

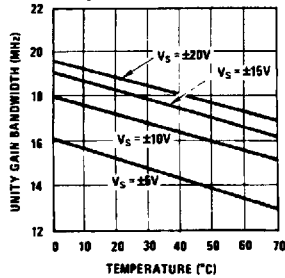

Voltage Follower Slew Rate

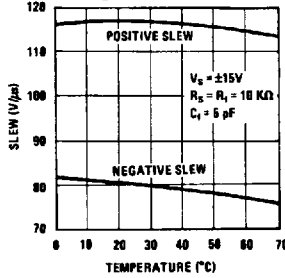

Inverter Settling Time

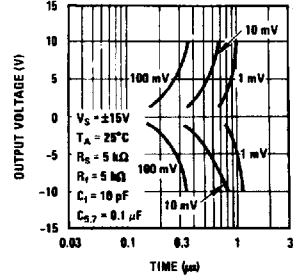

Large Signal Frequency Response

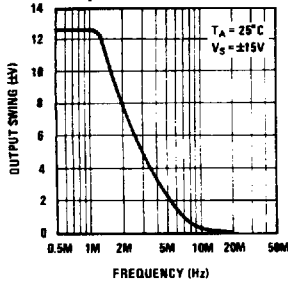

Open Loop Frequency Response

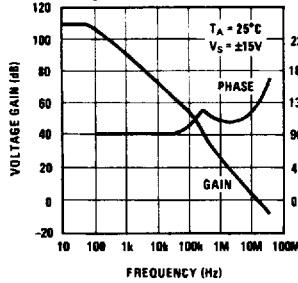

Voltage Follower Pulse Response

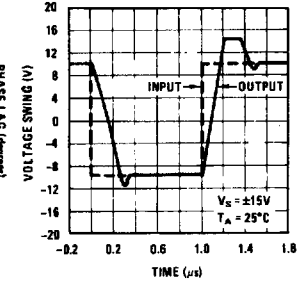

Large Signal Frequency Response

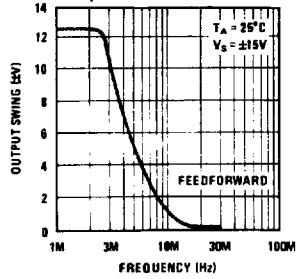

Open Loop Frequency Response

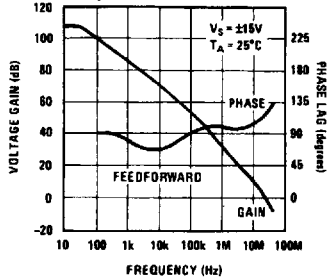

Inverter Pulse Response

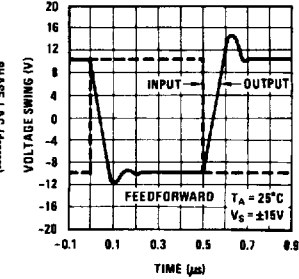

NATL SEMICOND (LINEAR)

TL/H/7766-7

LM118/LM218/LM318

## Auxiliary Circuits

## NATL SEMICOND (LINEAR)

### Feedforward Compensation for Greater Inverting Slew Rate†

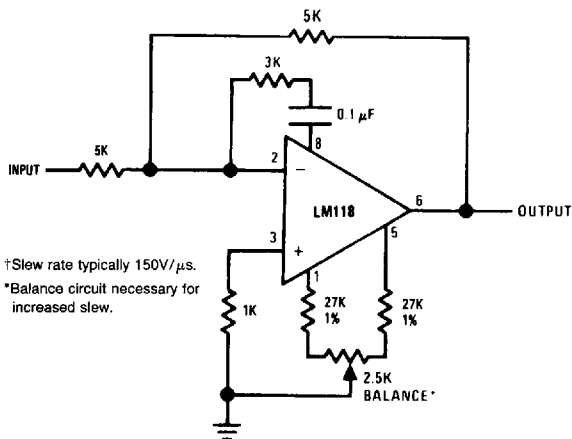

†Slew rate typically 150V/μs.  
\*Balance circuit necessary for increased slew.

TL/H/7766-8

### Compensation for Minimum Settling† Time

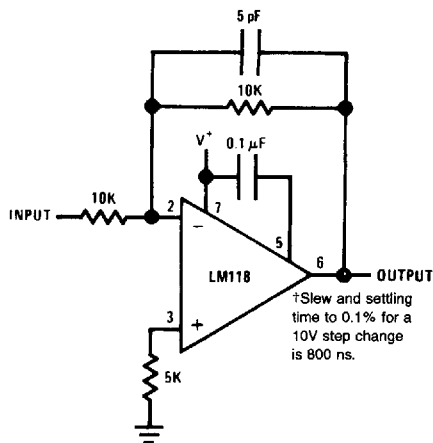

†Slew and settling time to 0.1% for a 10V step change is 800 ns.

TL/H/7766-9

### Offset Balancing

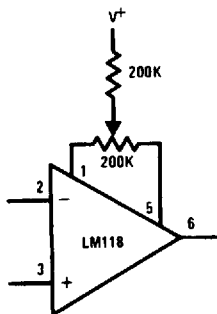

TL/H/7766-10

### Isolating Large Capacitive Loads

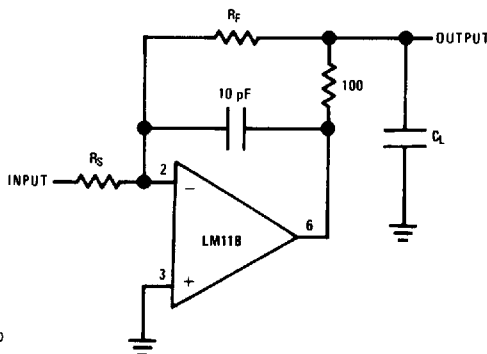

TL/H/7766-11

### Overcompensation

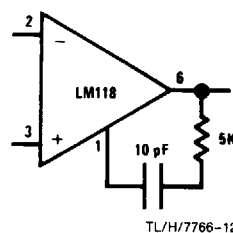

TL/H/7766-12

## Typical Applications

### Fast Voltage Follower\*

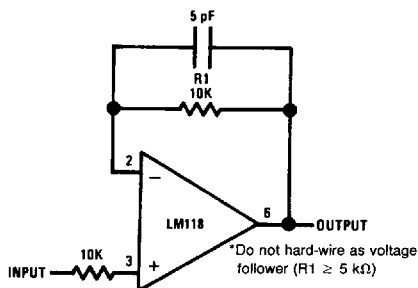

\*Do not hard-wire as voltage follower (R1 ≥ 5 kΩ)

TL/H/7766-13

### Integrator or Slow Inverter

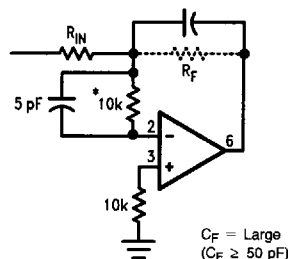

C<sub>F</sub> = Large  
(C<sub>F</sub> ≥ 50 pF)

TL/H/7766-14

\*Do not hard-wire as integrator or slow inverter; insert a 10k-5 pF network in series with the input, to prevent oscillation.

**Typical Applications** (Continued)

NATL SEMICON (LINEAR)

**Fast Summing Amplifier**

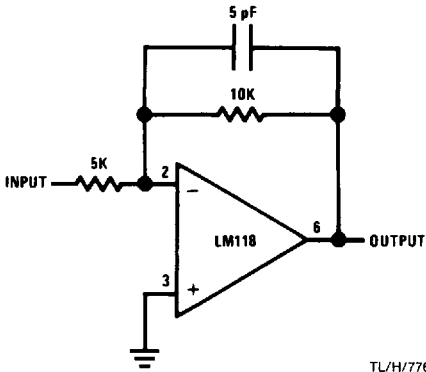

TL/H/7766-15

**Differential Amplifier**

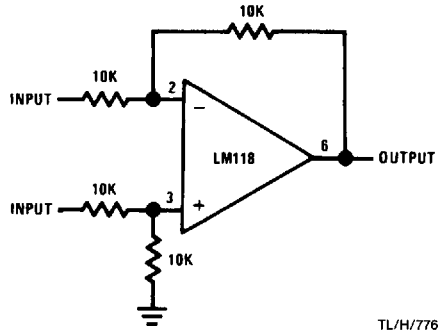

TL/H/7766-16

**Fast Sample and Hold**

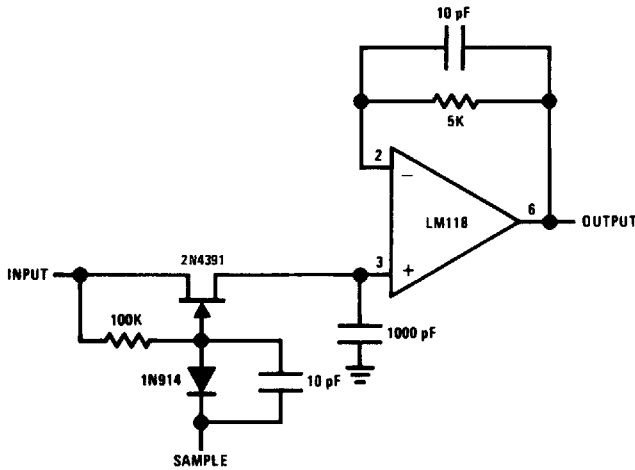

TL/H/7766-18

**D/A Converter Using Ladder Network**

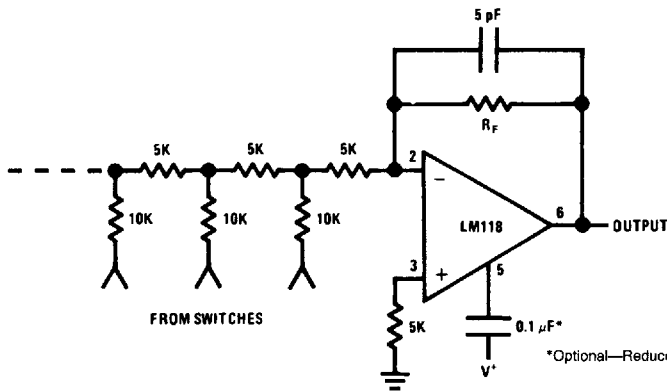

\*Optional—Reduces settling time.

TL/H/7766-19

Typical Applications (Continued) NATL SEMICOND (LINEAR)

TL/H/7766-17

Four Quadrant Multiplier

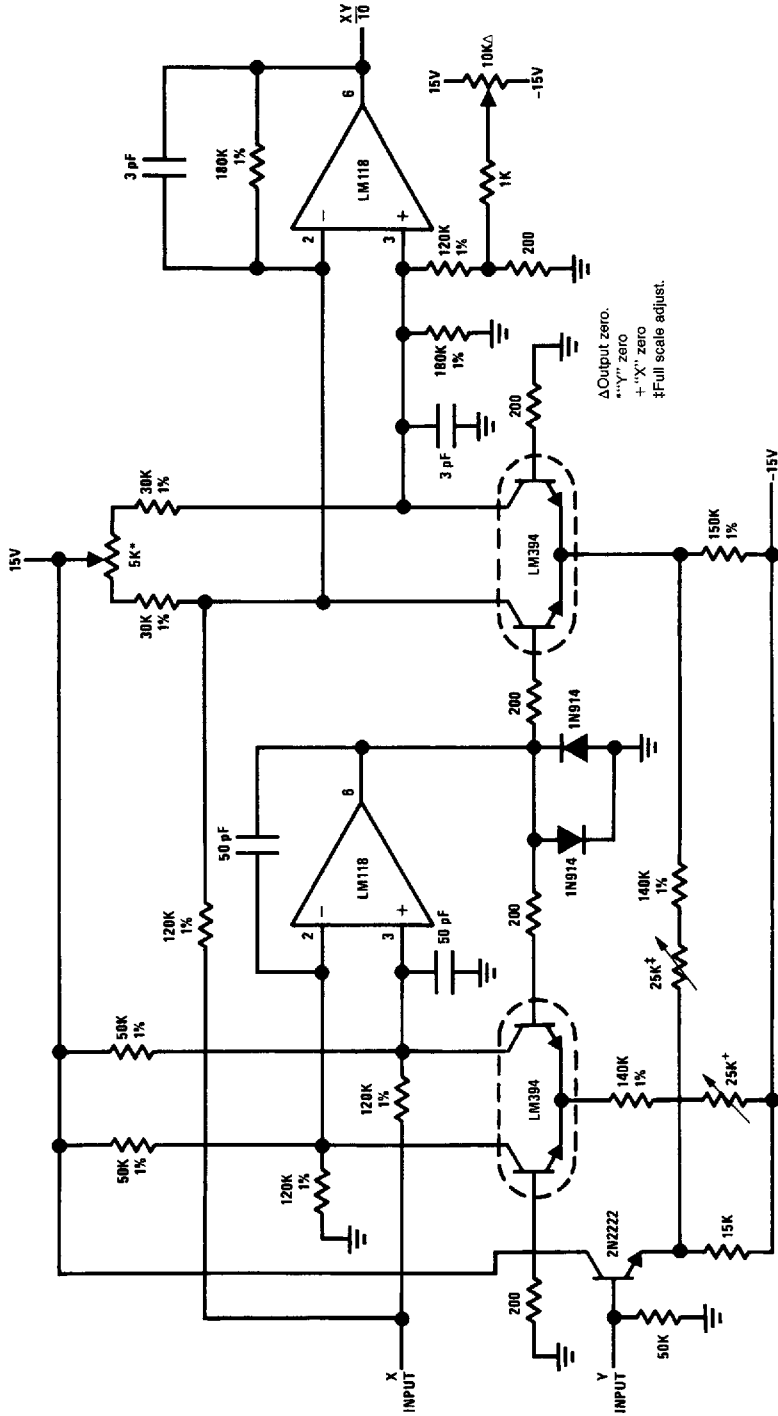



**Typical Applications** (Continued)

**NATL SEMICOND (LINEAR)**

**D/A Converter Using Binary Weighted Network**

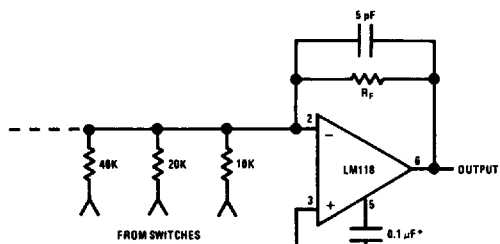

\*Optional—Reduces settling time.

TL/H/7766-20

**Fast Summing Amplifier with Low Input Current**

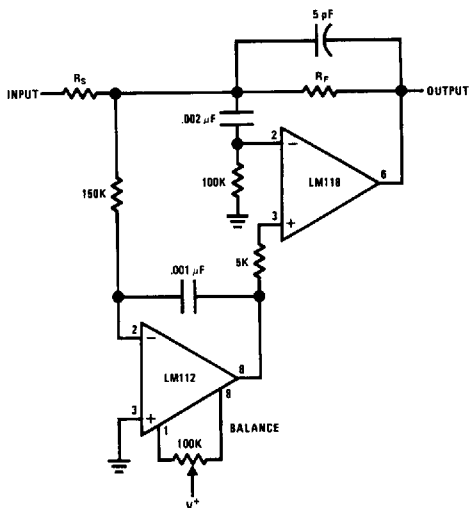

TL/H/7766-21

**Wein Bridge Sine Wave Oscillator**

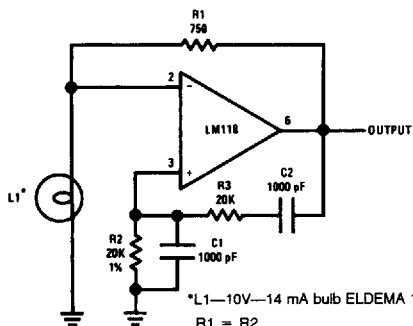

\*L1—10V—14 mA bulb ELDEMA 1869

R1 = R2

C1 = C2

$$f = \frac{1}{2\pi R_2 C_1}$$

TL/H/7766-22

**Instrumentation Amplifier**

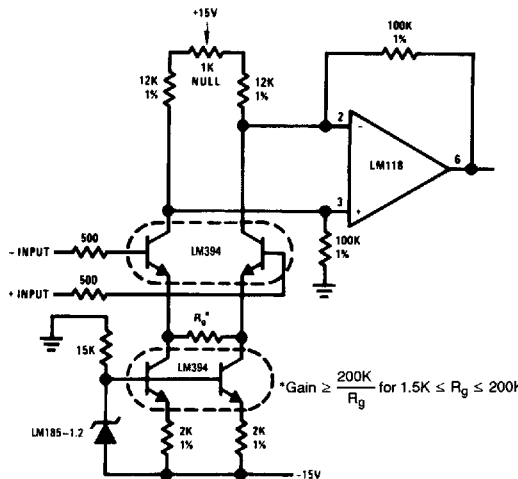

\*Gain  $\geq \frac{200K}{R_g}$  for  $1.5K \leq R_g \leq 200K$

TL/H/7766-23

Schematic Diagram

NATL SEMICOND (LINEAR)

TL/H/7766-1

