

RN2307, 2308, 2309

SWITCHING, INVERTER CIRCUIT, INTERFACE CIRCUIT
AND DRIVER CIRCUIT APPLICATIONS.

- With Built-in Bias Resistors
- Simplify Circuit Design
- Reduce a Quantity of Parts and Manufacturing Process
- Complementary to RN1307~1309

EQUIVALENT CIRCUIT

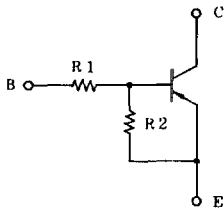

BIAS RESISTOR VALUES

TYPE No.	R1 (kΩ)	R2 (kΩ)
RN2307	10	47
RN2308	22	47
RN2309	47	22

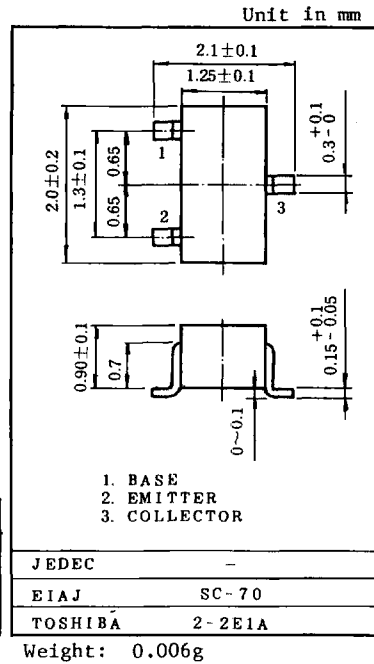

MAXIMUM RATINGS (Ta=25°C)

CHARACTERISTIC	SYMBOL	RATING	UNIT
Collector-Base Voltage	V _{CBO}	-50	V
Collector-Emitter Voltage	V _{CEO}	-50	V
Emitter-Base Voltage	V _{EBO}	RN2307	-6
		RN2308	-7
		RN2309	-15
Collector Current	I _C	-100	mA
Collector Power Dissipation	P _C	100	mW
Junction Temperature	T _j	150	°C
Storage Temperature Range	T _{stg}	-55~150	°C

ELECTRICAL CHARACTERISTICS (Ta=25°C)

CHARACTERISTIC		SYMBOL	TEST CONDITION	MIN.	TYP.	MAX.	UNIT
Collector Cut-off Current		ICBO	V _{CB} =-50V, I _E =0	-	-	-100	nA
		ICEO	V _{CE} =-50V, I _B =0	-	-	-500	nA
Emitter Cut-off Current	RN2307	IEBO	V _{EB} =-6V, I _C =0	-0.081	-	-0.15	mA
	RN2308		V _{EB} =-7V, I _C =0	-0.078	-	-0.145	
	RN2309		V _{EB} =-15V, I _C =0	-0.167	-	-0.311	
DC Current Gain	RN2307	h _{FE}	V _{CE} =-5V, I _C =-10mA	80	-	-	-
	RN2308			80	-	-	
	RN2309			70	-	-	
Collector-Emitter Saturation Voltage		V _{CE(sat)}	I _C =-5mA, I _B =-0.25mA	-	-0.1	-0.3	V
Input Voltage (ON)	RN2307	V _{I(ON)}	V _{CE} =-0.2V, I _C =-5mA	-0.7	-	-1.8	V
	RN2308			-1.0	-	-2.6	
	RN2309			-2.2	-	-5.8	
Input Voltage (OFF)	RN2307	V _{I(OFF)}	V _{CE} =-5V, I _C =-0.1mA	-0.5	-	-1.0	V
	RN2308			-0.6	-	-1.16	
	RN2309			-1.5	-	-2.6	
Transition Frequency		f _T	V _{CE} =-10V, I _C =5mA	-	200	-	MHz
Collector Output Capacitance		C _{ob}	V _{CB} =-10V, I _E =0 f=1MHz	-	3	6	pF
Input Resistor	RN2307	R ₁		7	10	13	kΩ
	RN2308			15.4	22	28.6	
	RN2309			32.9	47	61.1	
Resistor Ratio	RN2307	R _{1/R2}		0.191	0.213	0.232	-
	RN2308			0.421	0.468	0.515	
	RN2309			1.92	2.14	2.35	

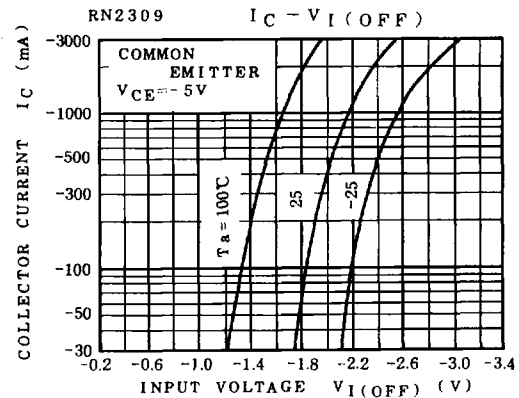
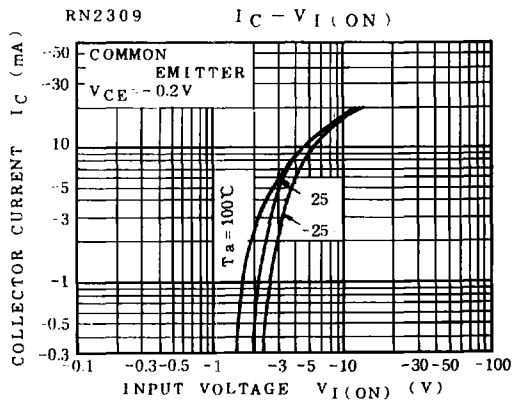
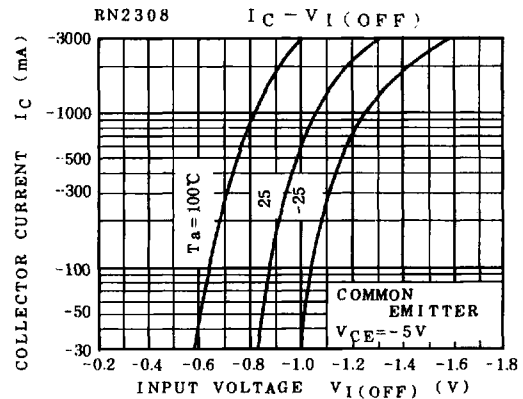
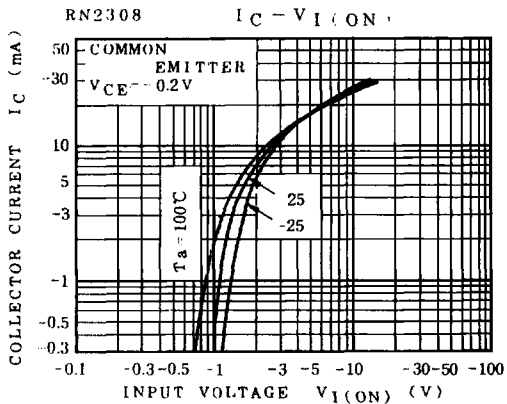
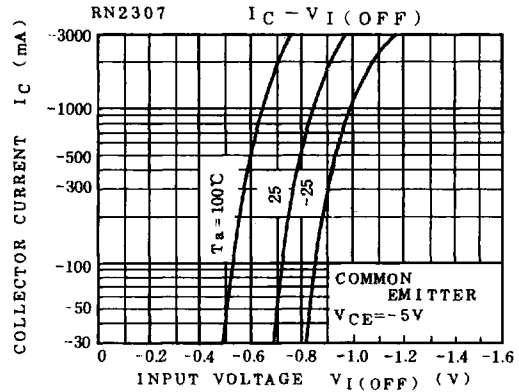
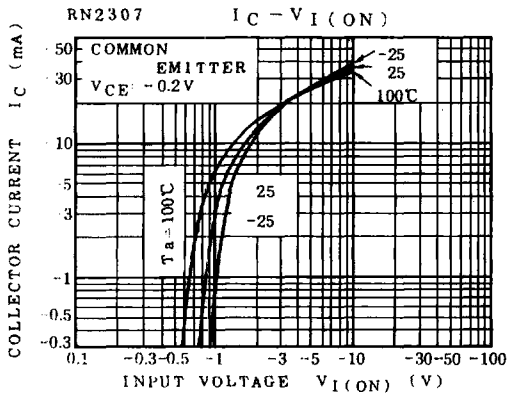

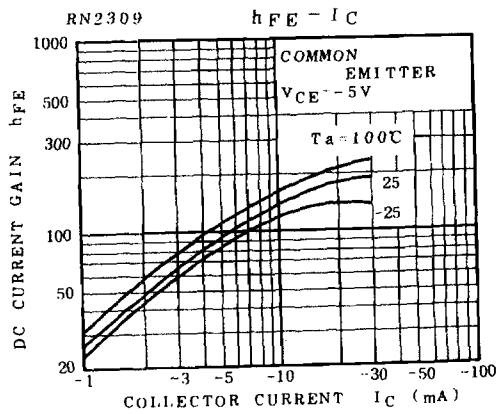
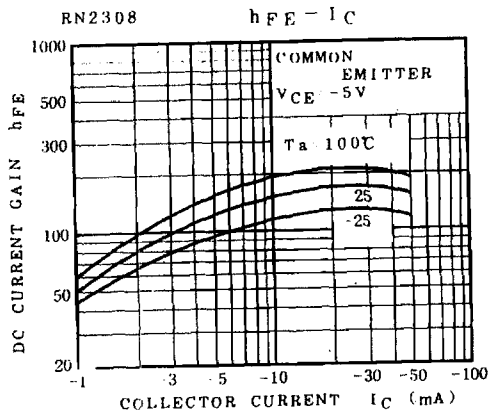
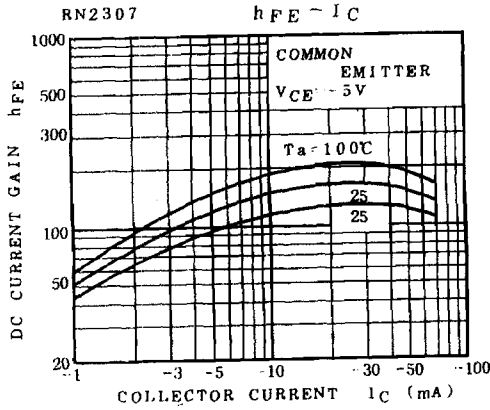

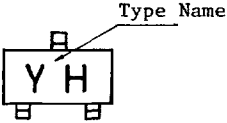
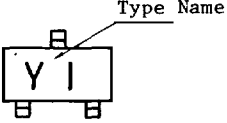
TYPE NAME	MARKING
RN2307	
RN2308	
RN2309	