



## GENERAL DESCRIPTION

 The ICS840004 is a 4 output LVCMOS/LVTTL Synthesizer optimized to generate Ethernet reference clock frequencies and is a member of the HiPerClocks™ family of high performance clock solutions from ICS. Using a 26.5625MHz, 18pF parallel resonant crystal, the following frequencies can be generated based on the 2 frequency select pins (F\_SEL1:0): 212.5MHz, 159.375MHz, 156.25MHz, 106.25MHz, and 53.125MHz. The ICS840004 uses ICS' 3<sup>rd</sup> generation low phase noise VCO technology and can achieve 1ps or lower typical random rms phase jitter, easily meeting Ethernet jitter requirements. The ICS840004 is packaged in a small 20-pin TSSOP package.

## FEATURES

- Four LVCMOS/LVTTL outputs, 15Ω typical output impedance
- Selectable crystal oscillator interface or LVCMOS single-ended input
- Supports the following input frequencies: 212.5MHz, 159.375MHz, 156.25MHz, 106.25MHz and 53.125MHz
- VCO range: 470MHz - 750MHz
- RMS phase jitter @ 212.5MHz (637kHz - 10MHz): 0.98ps typical,  $V_{DD0} = 3.3V$   
Phase noise:  

Offset	Noise Power
100Hz .....	-88.8 dBc/Hz
1kHz .....	-109.0 dBc/Hz
10kHz .....	-116.1 dBc/Hz
100kHz .....	-117.5 dBc/Hz
- Full 3.3V or 3.3V core/2.5V output supply mode
- 0°C to 70°C ambient operating temperature
- Available in both standard and lead-free RoHS compliant packages

FREQUENCY SELECT FUNCTION TABLE

Input Frequency	Inputs					Output Frequency Range
	F_SEL1	F_SEL0	M Divider Value	N Divider Value	M/N Ratio Value	
26.5625	0	0	24	3	8	212.5
26.5625	0	1	24	4	6	159.375
26.5625	1	0	24	6	4	106.25
26.5625	1	1	24	12	2	53.125
26.04166	0	1	24	4	6	156.25

## BLOCK DIAGRAM

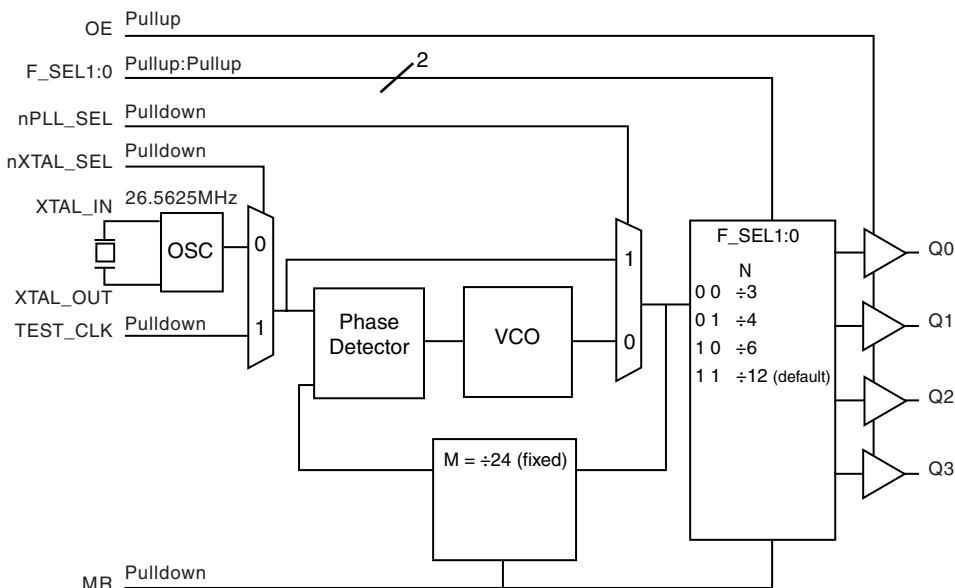

## PIN ASSIGNMENT

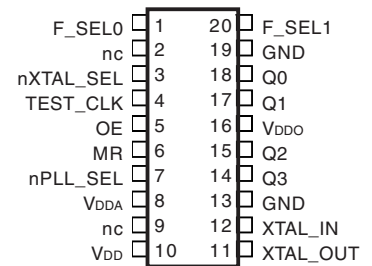

### ICS840004

#### 20-Lead TSSOP

6.5mm x 4.4mm x 0.92mm  
package body  
**G Package**  
Top View

The Preliminary Information presented herein represents a product in prototyping or pre-production. The noted characteristics are based on initial product characterization. Integrated Circuit Systems, Incorporated (ICS) reserves the right to change any circuitry or specifications without notice.



**TABLE 1. PIN DESCRIPTIONS**

Number	Name	Type		Description
1	F_SEL0	Input	Pullup	Frequency select pin. LVCMOS/LVTTL interface levels.
2, 9	nc	Unused		No connect.
3	nXTAL_SEL	Input	Pulldown	Selects between the crystal or TEST_CLK inputs as the PLL reference source. When HIGH, selects TEST_CLK. When LOW, selects XTAL inpus. LVCMOS/LVTTL interface levels.
4	TEST_CLK	Input	Pulldown	Single-ended LVCMOS/LVTTL clock input.
5	OE	Input	Pullup	Output enable pin. When HIGH, the outputs are active. When LOW, the outputs are in a high impedance state. LVCMOS/LVTTL interface levels.
6	MR	Input	Pulldown	Active HIGH Master Reset. When logic HIGH, the internal dividers are reset causing the otuputs to go low. When logic LOW, the internal dividers and the outputs are enabled. LVCMOS/LVTTL interface levels.
7	nPLL_SEL	Input	Pulldown	PLL Bypass. When LOW, the output is driven from the VCO output. When HIGH, the PLL is bypassed and the output frequency = reference clock frequency/N output divider. LVCMOS/LVTTL interface levels.
8	V <sub>DDA</sub>	Power		Analog supply pin.
10	V <sub>DD</sub>	Power		Core supply pin.
11, 12	XTAL_OUT, XTAL_IN	Input		Crystal oscillator interface. XTAL_OUT is the output. XTAL_IN is the input.
13, 19	GND	Power		Power supply ground.
14, 15, 17, 18	Q3, Q2, Q1, Q0	Output		Single-ended clock outputs. LVCMOS/LVTTL interface levels. 15Ω typical output impedance.
16	V <sub>DDO</sub>	Power		Output supply pin.
20	F_SEL1	Input	Pullup	Frequency select pin. LVCMOS/LVTTL interface levels.

NOTE: *Pullup* and *Pulldown* refer to internal input resistors. See Table 2, Pin Characteristics, for typical values.

**TABLE 2. PIN CHARACTERISTICS**

Symbol	Parameter	Test Conditions	Minimum	Typical	Maximum	Units
C <sub>IN</sub>	Input Capacitance			4		pF
C <sub>PD</sub>	Power Dissipation Capacitance	V <sub>DD</sub> , V <sub>DDA</sub> , V <sub>DDO</sub> = 3.465V		TBD		pF
		V <sub>DD</sub> , V <sub>DDA</sub> = 3.465V, V <sub>DDO</sub> = 2.625V		TBD		pF
R <sub>PULLUP</sub>	Input Pullup Resistor			51		kΩ
R <sub>PULLDOWN</sub>	Input Pulldown Resistor			51		kΩ
R <sub>OUT</sub>	Output Impedance			15		Ω



**ABSOLUTE MAXIMUM RATINGS**

Supply Voltage, $V_{DD}$	4.6V
Inputs, $V_i$	-0.5V to $V_{DD} + 0.5V$
Outputs, $V_o$	-0.5V to $V_{DD} + 0.5V$
Package Thermal Impedance, $\theta_{JA}$	73.2°C/W (0 lfpm)
Storage Temperature, $T_{STG}$	-65°C to 150°C

NOTE: Stresses beyond those listed under Absolute Maximum Ratings may cause permanent damage to the device. These ratings are stress specifications only. Functional operation of product at these conditions or any conditions beyond those listed in the *DC Characteristics* or *AC Characteristics* is not implied. Exposure to absolute maximum rating conditions for extended periods may affect product reliability.

**TABLE 3A. POWER SUPPLY DC CHARACTERISTICS,  $V_{DD} = V_{DDA} = 3.3V \pm 5\%$ ,  $V_{DDO} = 3.3V \pm 5\%$  OR  $2.5V \pm 5\%$ ,  $T_A = 0^\circ C$  TO  $70^\circ C$**

Symbol	Parameter	Test Conditions	Minimum	Typical	Maximum	Units
$V_{DD}$	Core Supply Voltage		3.135	3.3	3.465	V
$V_{DDA}$	Analog Supply Voltage		3.135	3.3	3.465	V
$V_{DDO}$	Output Supply Voltage		3.135	3.3	3.465	V
			2.375	2.5	2.625	V
$I_{DD}$	Power Supply Current			87		mA
$I_{DDA}$	Analog Supply Current			8		mA
$I_{DDO}$	Output Supply Current			5		mA

**TABLE 3B. LVCMOS/LVTTL DC CHARACTERISTICS,  $V_{DD} = V_{DDA} = 3.3V \pm 5\%$ ,  $V_{DDO} = 3.3V \pm 5\%$  OR  $2.5V \pm 5\%$ ,  $T_A = 0^\circ C$  TO  $70^\circ C$**

Symbol	Parameter	Test Conditions	Minimum	Typical	Maximum	Units
$V_{IH}$	Input High Voltage	F_SEL1:0, nPLL_SEL, nXTAL_SEL, OE, MR	2		$V_{DD} + 0.3$	V
		TEST_CLK	2		$V_{DD} + 0.3$	V
$V_{IL}$	Input Low Voltage	F_SEL1:0, nPLL_SEL, nXTAL_SEL, OE, MR	-0.3		0.8	V
		TEST_CLK	-0.3		1.3	V
$I_{IH}$	Input High Current	OE, F_SEL0, F_SEL1, nPLL_SEL, MR, nXTAL_SEL, TEST_CLK	$V_{DD} = V_{IN} = 3.465V$		5	$\mu A$
			$V_{DD} = V_{IN} = 3.465V$		150	$\mu A$
$I_{IL}$	Input Low Current	OE, F_SEL0, F_SEL1, nPLL_SEL, MR, nXTAL_SEL, TEST_CLK	$V_{DD} = 3.465V, V_{IN} = 0V$	-150		$\mu A$
			$V_{DD} = 3.465V, V_{IN} = 0V$	-5		$\mu A$
$V_{OH}$	Output High Voltage; NOTE 1		$V_{DDO} = 3.3V \pm 5\%$	2.6		V
			$V_{DDO} = 2.5V \pm 5\%$	1.8		V
$V_{OL}$	Output Low Voltage; NOTE 1		$V_{DDO} = 3.3V$ or $2.5V \pm 5\%$		0.5	V

NOTE 1: Outputs terminated with  $50\Omega$  to  $V_{DDO}/2$ . See Parameter Measurement Information, Output Load Test Circuit.

**TABLE 4. CRYSTAL CHARACTERISTICS**

Parameter	Test Conditions	Minimum	Typical	Maximum	Units
Mode of Oscillation		Fundamental			
Frequency			26.5625		MHz
Equivalent Series Resistance (ESR)				50	$\Omega$
Shunt Capacitance				7	pF
Drive Level				1	mW

NOTE: Characterized using an 18pF parallel resonant crystal.



**TABLE 5A. AC CHARACTERISTICS,  $V_{DD} = V_{DDA} = V_{DDO} = 3.3V \pm 5\%$ ,  $T_A = 0^\circ C$  TO  $70^\circ C$**

Symbol	Parameter	Test Conditions	Minimum	Typical	Maximum	Units
$f_{OUT}$	Output Frequency			212.5		MHz
				159.375		MHz
				156.25		MHz
				106.25		MHz
				53.125		MHz
$t_{sk(o)}$	Output Skew; NOTE 1, 3			TBD		ps
$f_{jit}(\emptyset)$	RMS Phase Jitter (Random); NOTE 2	212.5MHz (637KHz - 10MHz)		0.98		ps
		159.375MHz (637KHz - 10MHz)		0.84		ps
		156.25MHz (1.875MHz - 20MHz)		TBD		ps
		106.25MHz (637KHz - 10MHz)		0.83		ps
		53.125MHz (637KHz - 10MHz)		1.0		ps
$t_L$	PLL Lock Time				1	ms
$t_R / t_F$	Output Rise/Fall Time	20% to 80%		500		ps
odc	Output Duty Cycle			50		%

NOTE 1: Defined as skew between outputs at the same supply voltages and with equal load conditions. Measured at  $V_{DDO}/2$ .

NOTE 2: Please refer to the Phase Noise Plot.

NOTE 3: This parameter is defined in accordance with JEDEC Standard 65.

**TABLE 5B. AC CHARACTERISTICS,  $V_{DD} = V_{DDA} = 3.3V \pm 5\%$ ,  $V_{DDO} = 3.3V \pm 5\%$  OR  $2.5V \pm 5\%$ ,  $T_A = 0^\circ C$  TO  $70^\circ C$**

Symbol	Parameter	Test Conditions	Minimum	Typical	Maximum	Units
$f_{OUT}$	Output Frequency			212.5		MHz
				159.375		MHz
				156.25		MHz
				106.25		MHz
				53.125		MHz
$t_{sk(o)}$	Output Skew; NOTE 1, 3			TBD		ps
$f_{jit}(\emptyset)$	RMS Phase Jitter (Random); NOTE 2	212.5MHz (637KHz - 10MHz)		0.93		ps
		159.375MHz (637KHz - 10MHz)		0.76		ps
		156.25MHz (1.875MHz - 20MHz)		TBD		ps
		106.25MHz (637KHz - 10MHz)		0.81		ps
		53.125MHz (637KHz - 10MHz)		0.99		ps
$t_L$	PLL Lock Time				1	ms
$t_R / t_F$	Output Rise/Fall Time	20% to 80%		500		ps
odc	Output Duty Cycle			50		%

For notes see above, Table 4A.



**TYPICAL PHASE NOISE AT 53.125MHz @3.3V**

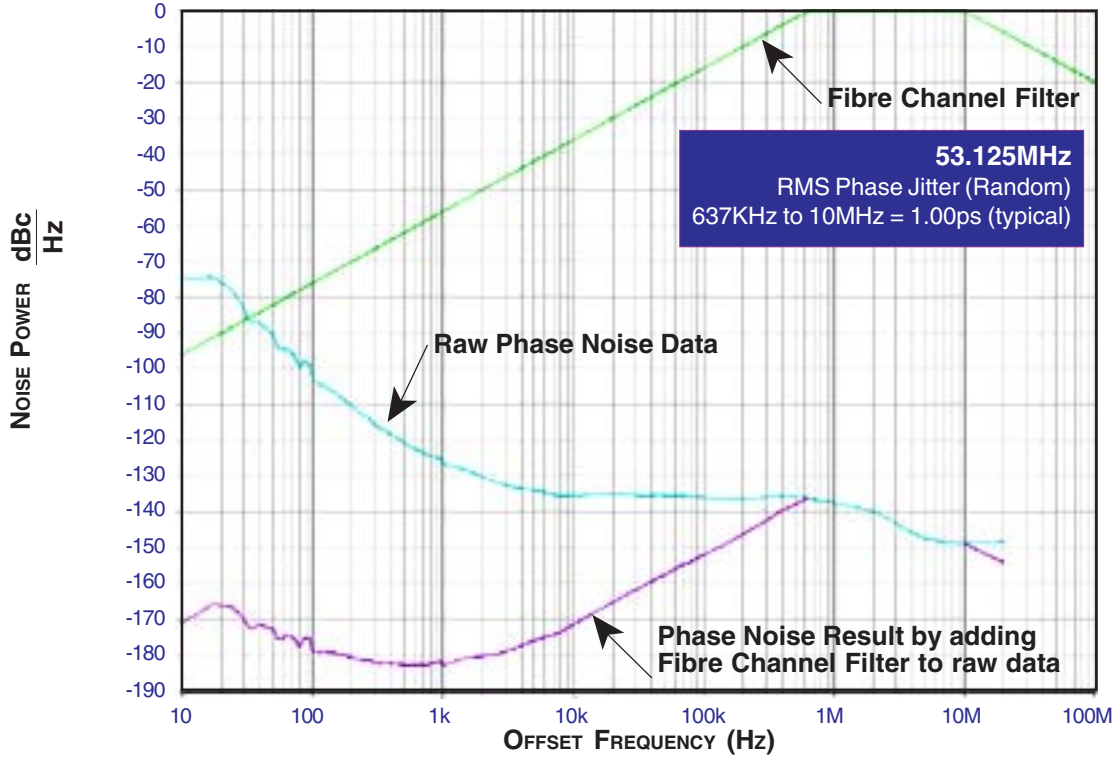

**TYPICAL PHASE NOISE AT 53.125MHz @2.5V**

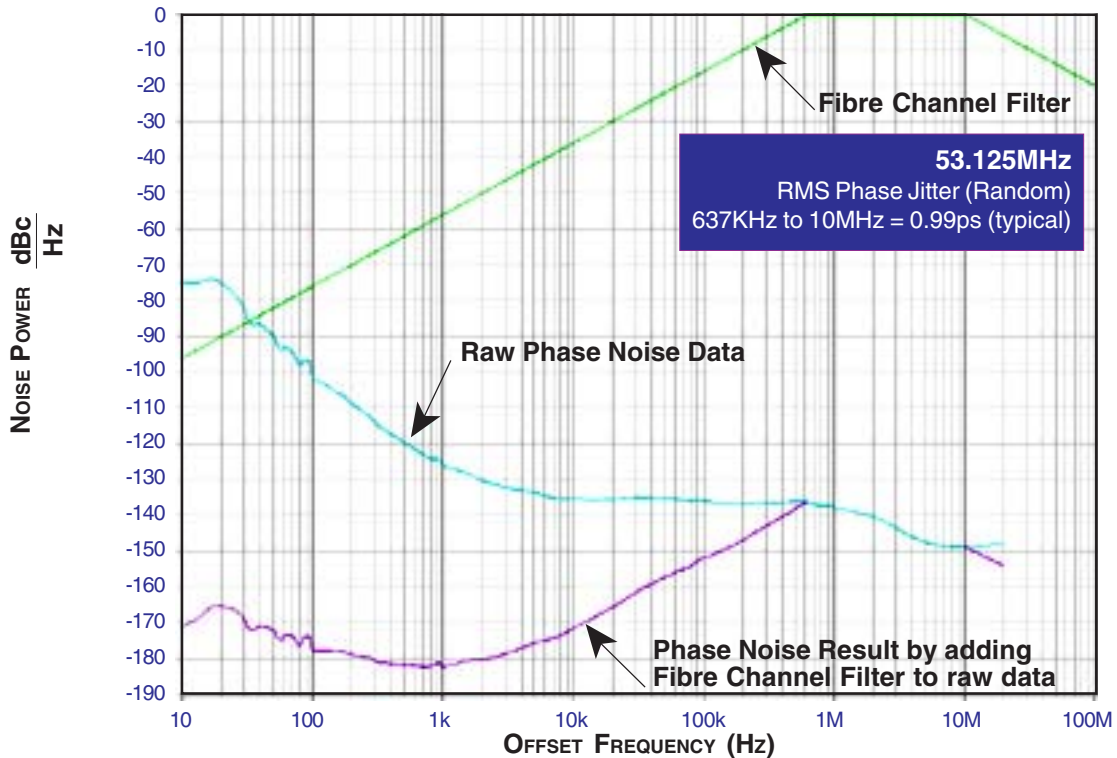



**TYPICAL PHASE NOISE AT 106.25MHz @3.3V**

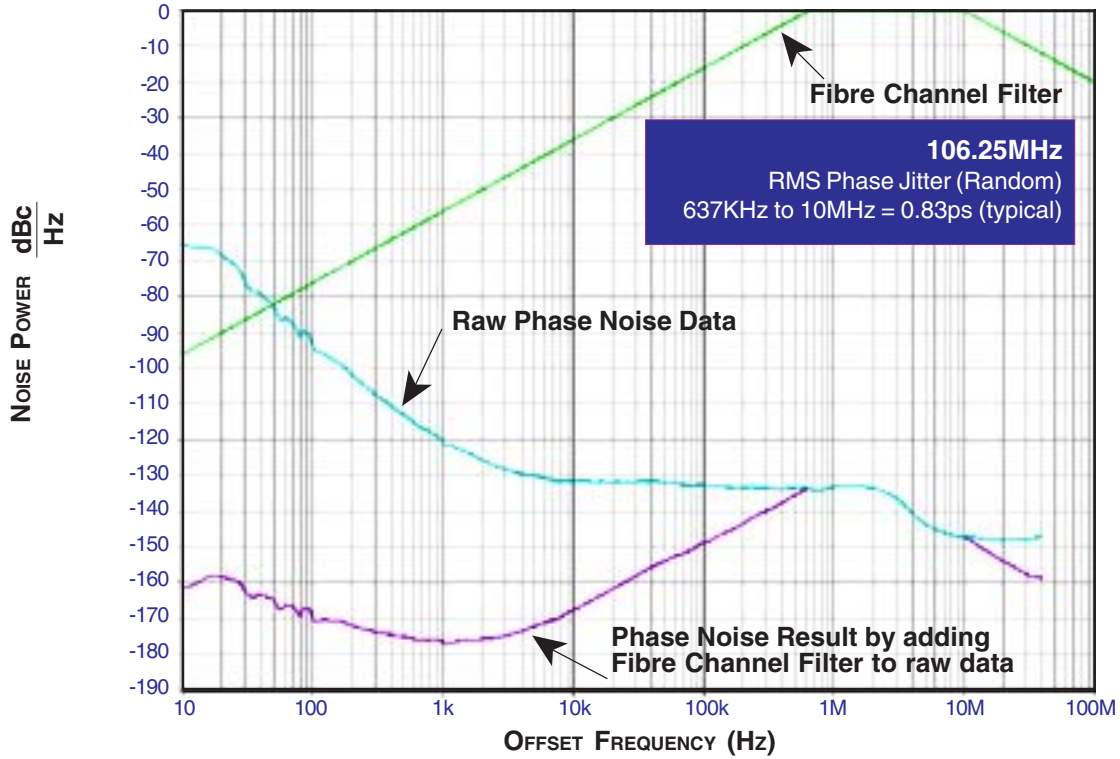

**TYPICAL PHASE NOISE AT 106.25MHz @ 2.5V**

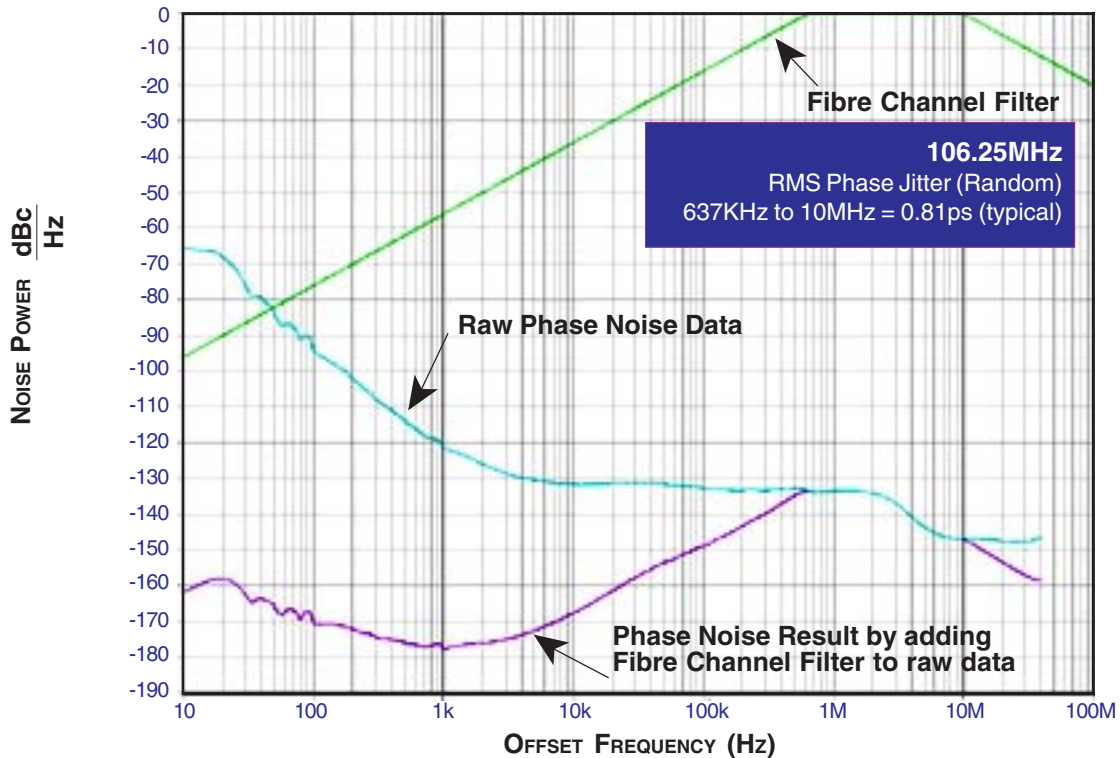



**TYPICAL PHASE NOISE AT 159.375MHz @3.3V**

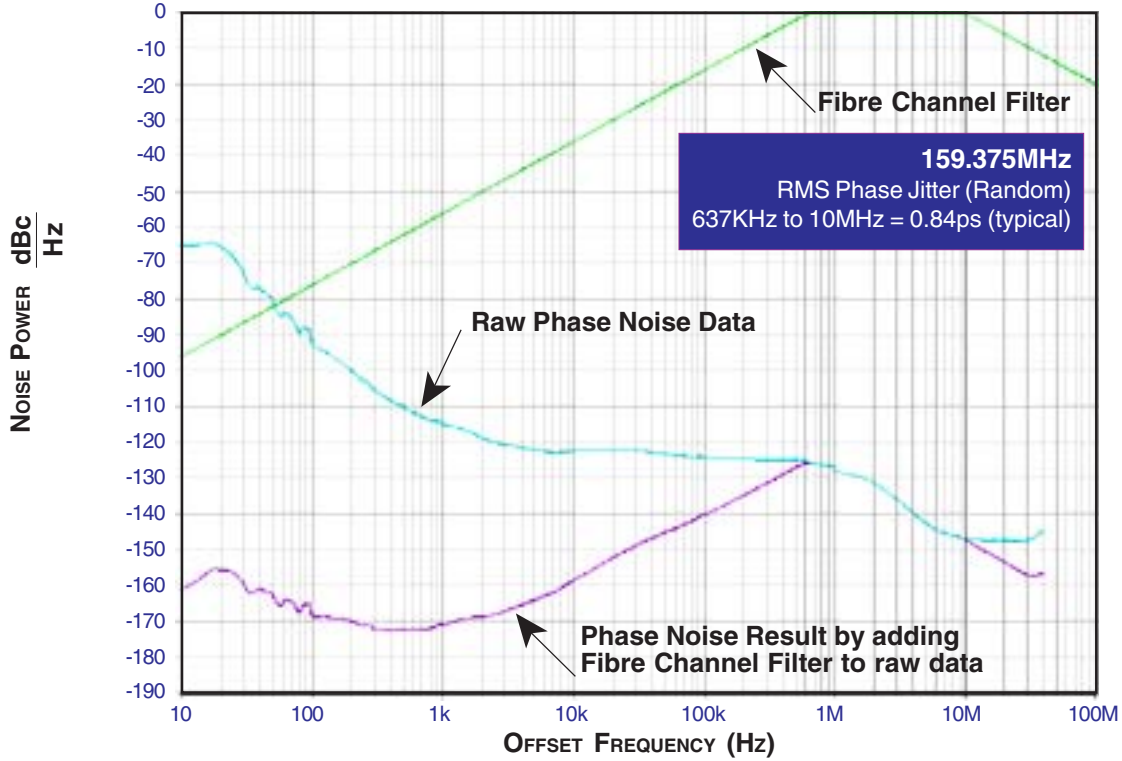

**TYPICAL PHASE NOISE AT 159.375MHz@ 2.5V**

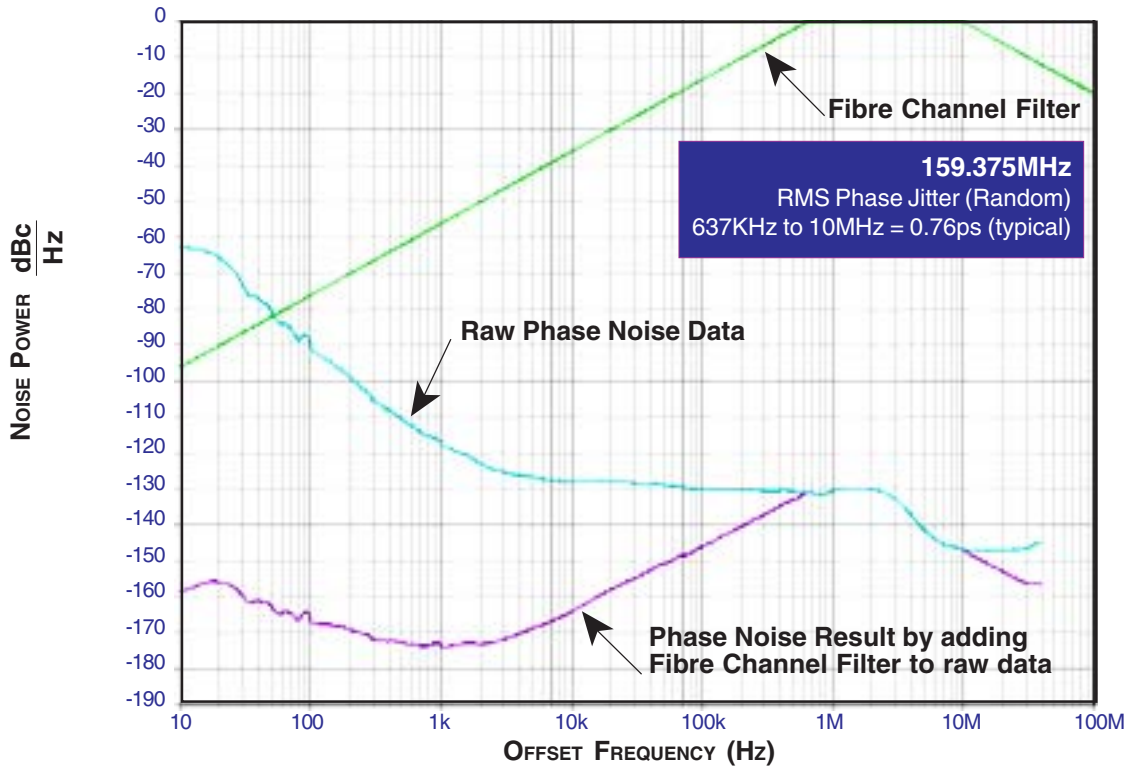



TYPICAL PHASE NOISE AT 212.5MHz@ 3.3V

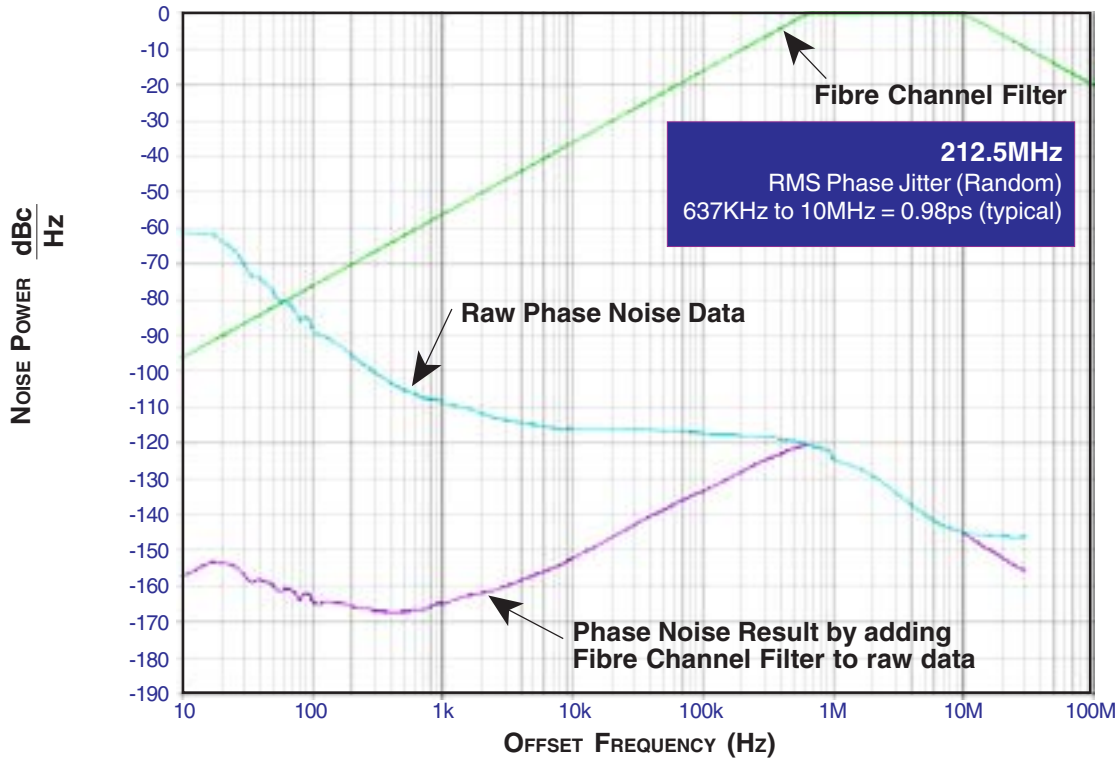

TYPICAL PHASE NOISE AT 212.5MHz@ 2.5V

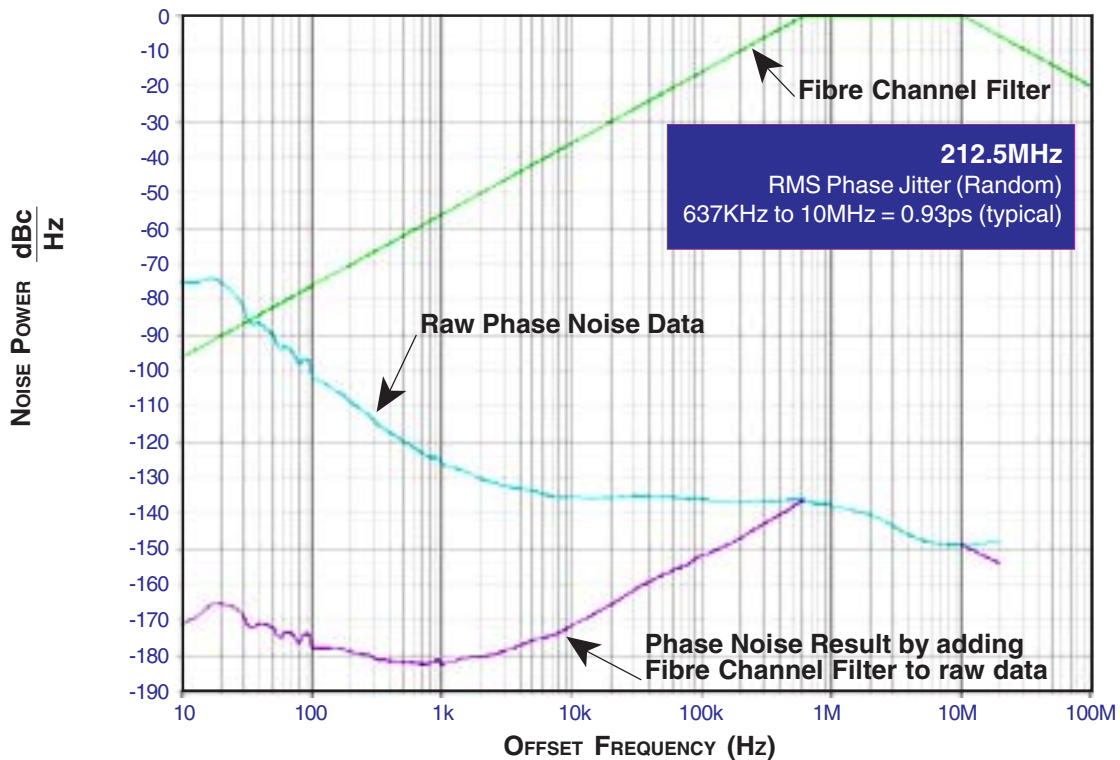





**PARAMETER MEASUREMENT INFORMATION**

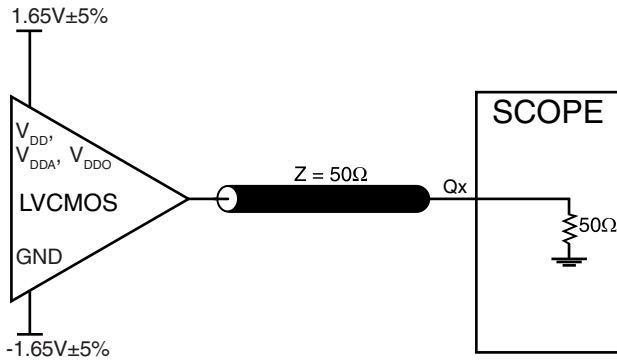

**3.3V CORE/3.3V OUTPUT LOAD AC TEST CIRCUIT**

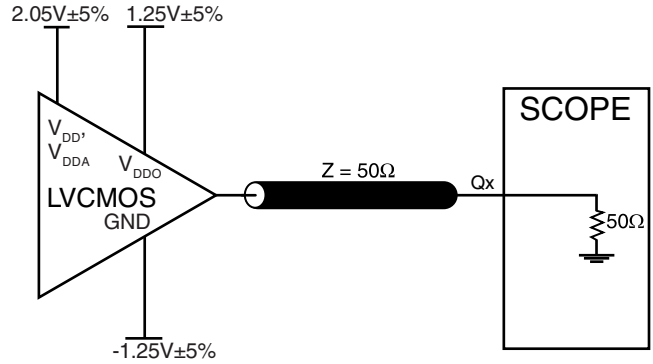

**3.3V CORE/2.5V OUTPUT LOAD AC TEST CIRCUIT**

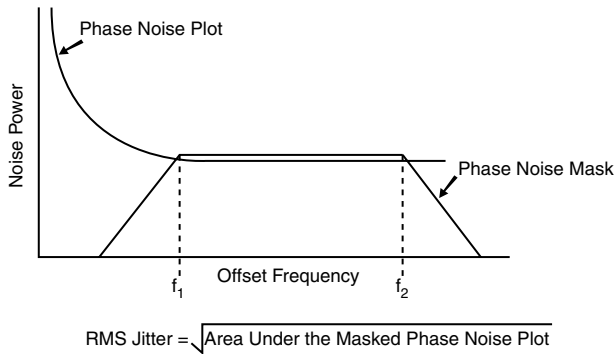

**RMS PHASE JITTER**

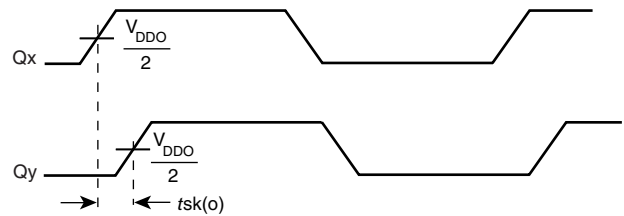

**OUTPUT SKEW**

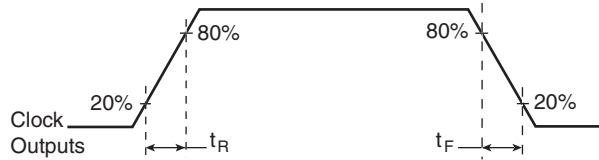

**OUTPUT RISE/FALL TIME**

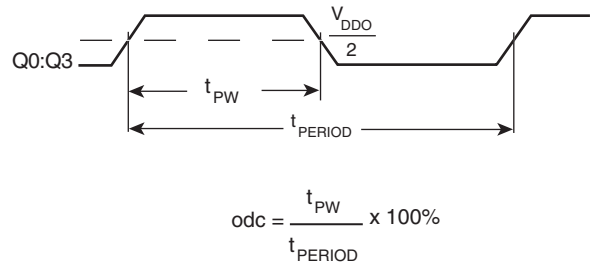

**OUTPUT DUTY CYCLE/PULSE WIDTH/PERIOD**



## APPLICATION INFORMATION

### POWER SUPPLY FILTERING TECHNIQUES

As in any high speed analog circuitry, the power supply pins are vulnerable to random noise. The ICS840004 provides separate power supplies to isolate any high switching noise from the outputs to the internal PLL.  $V_{DD}$ ,  $V_{DDA}$ , and  $V_{DDO}$  should be individually connected to the power supply plane through vias, and bypass capacitors should be used for each pin. To achieve optimum jitter performance, power supply isolation is required. *Figure 1* illustrates how a 10Ω resistor along with a 10μF and a .01μF bypass capacitor should be connected to each  $V_{DDA}$ .

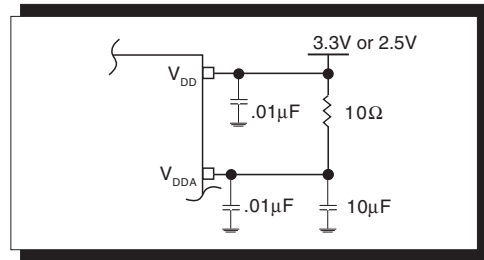
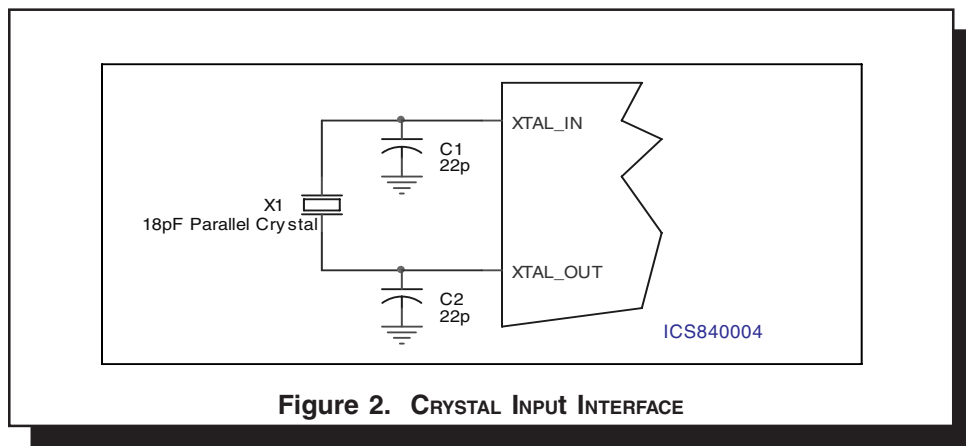

**FIGURE 1. POWER SUPPLY FILTERING**

### CRYSTAL INPUT INTERFACE

The ICS840004 has been characterized with 18pF parallel resonant crystals. The capacitor values shown in *Figure 2* below were

determined using a 26.5625MHz 18pF parallel resonant crystal and were chosen to minimize the ppm error.



**Figure 2. CRYSTAL INPUT INTERFACE**



**RECOMMENDATIONS FOR UNUSED INPUT AND OUTPUT PINS**

**INPUTS:**

**CRYSTAL INPUT:**

For applications not requiring the use of the crystal oscillator input, both XTAL\_IN and XTAL\_OUT can be left floating. Though not required, but for additional protection, a 1kΩ resistor can be tied from XTAL\_IN to ground.

**TEST\_CLK INPUT:**

For applications not requiring the use of the test clock, it can be left floating. Though not required, but for additional protection, a 1kΩ resistor can be tied from the TEST\_CLK to ground.

**LVCMOS CONTROL PINS:**

All control pins have internal pull-ups or pull-downs; additional resistance is not required but can be added for additional protection. A 1kΩ resistor can be used.

**OUTPUTS:**

**LVCMOS OUTPUT:**

All unused LVCMOS output can be left floating. We recommend that there is no trace attached.

**LAYOUT GUIDELINE**

Figure 3 shows a schematic example of the ICS840004. An example of LVCMOS termination is shown in this schematic. Additional LVCMOS termination approaches are shown in the LVCMOS Termination Application Note. In this example, an 18 pF parallel resonant 26.5625MHz crystal is used. The C1=22pF

and C2=22pF are recommended for frequency accuracy. For different board layout, the C1 and C2 may be slightly adjusted for optimizing frequency accuracy. 1KΩ pullup or pulldown resistors can be used for the logic control input pins.

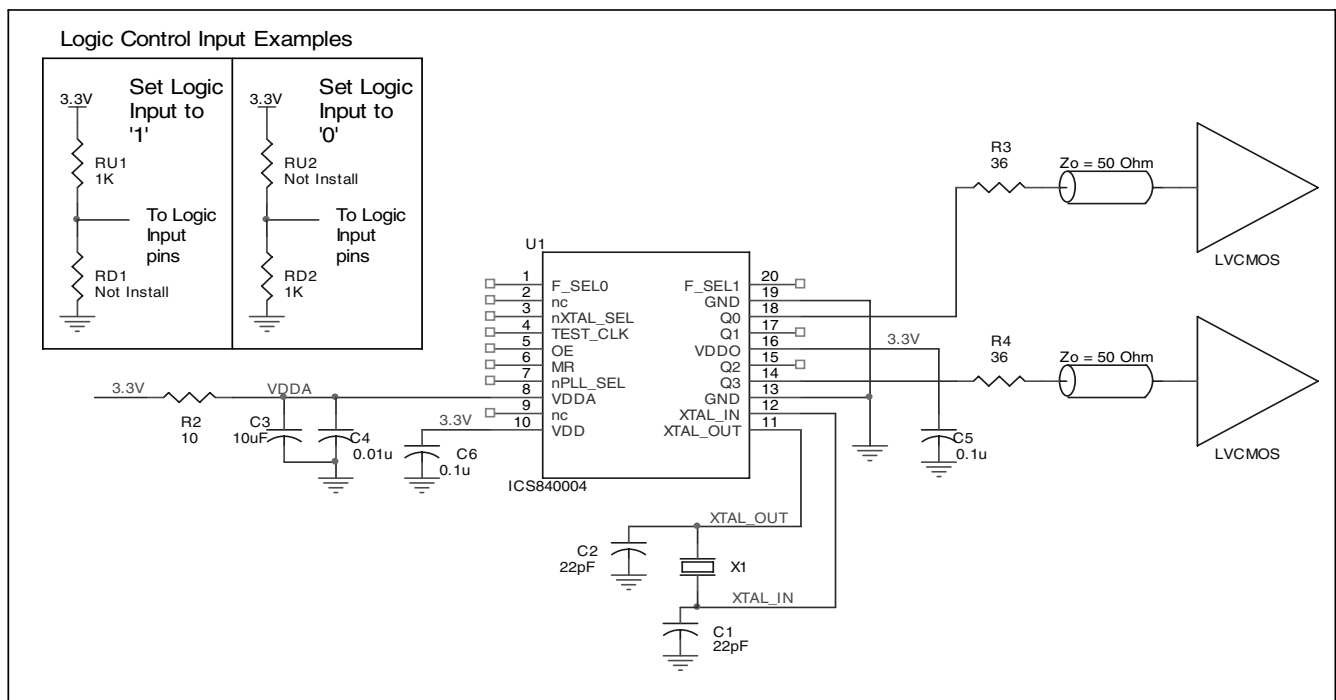

**FIGURE 3. ICS840004 SCHEMATIC EXAMPLE**



**RELIABILITY INFORMATION**

**TABLE 6.  $\theta_{JA}$  vs. AIR FLOW TABLE FOR 20 LEAD TSSOP**

$\theta_{JA}$ by Velocity (Linear Feet per Minute)			
	<b>0</b>	<b>200</b>	<b>500</b>
Single-Layer PCB, JEDEC Standard Test Boards	114.5°C/W	98.0°C/W	88.0°C/W
Multi-Layer PCB, JEDEC Standard Test Boards	73.2°C/W	66.6°C/W	63.5°C/W

**NOTE:** Most modern PCB designs use multi-layered boards. The data in the second row pertains to most designs.

**TRANSISTOR COUNT**

The transistor count for ICS840004 is: TBD



PACKAGE OUTLINE - G SUFFIX FOR 20 LEAD TSSOP

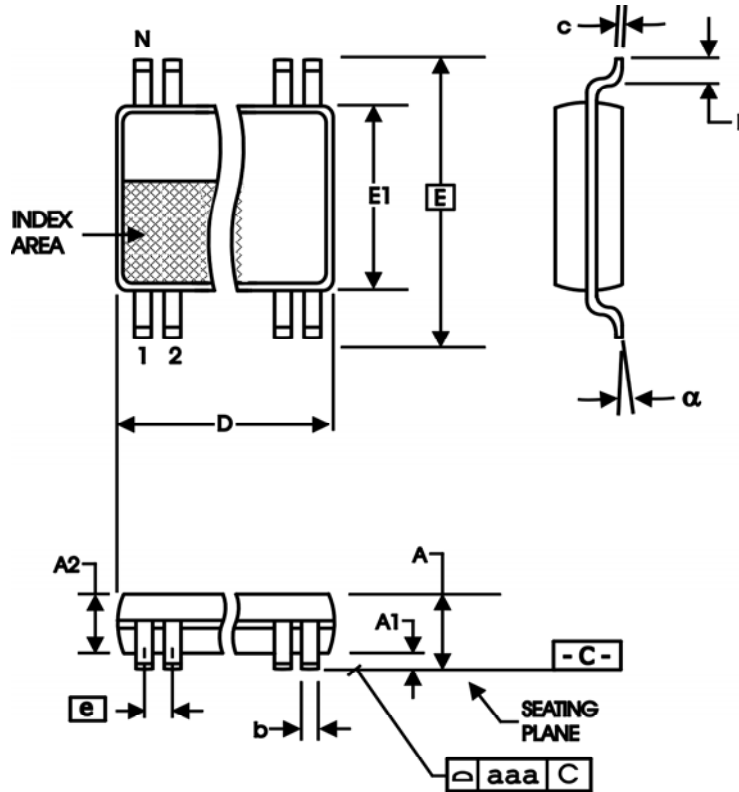

TABLE 7. PACKAGE DIMENSIONS

SYMBOL	Millimeters	
	MIN	MAX
N	20	
A	--	1.20
A1	0.05	0.15
A2	0.80	1.05
b	0.19	0.30
c	0.09	0.20
D	6.40	6.60
E	6.40 BASIC	
E1	4.30	4.50
e	0.65 BASIC	
L	0.45	0.75
alpha	0°	8°
aaa	--	0.10

Reference Document: JEDEC Publication 95, MO-153



Integrated  
Circuit  
Systems, Inc.

**PRELIMINARY**

**ICS840004**  
FEMTOCLOCKS™ CRYSTAL-TO-  
LVCMOS/LVTTL FREQUENCY SYNTHESIZER

**TABLE 8. ORDERING INFORMATION**

Part/Order Number	Marking	Package	Shipping Packaging	Temperature
ICS840004AG	ICS840004AG	20 Lead TSSOP	tube	0°C to 70°C
ICS840004AGT	ICS840004AG	20 Lead TSSOP	2500 tape & reel	0°C to 70°C
ICS840004AGLF	ICS840004AGL	20 Lead "Lead-Free" TSSOP	tube	0°C to 70°C
ICS840004AGLFT	ICS840004AGL	20 Lead "Lead-Free" TSSOP	2500 tape & reel	0°C to 70°C

NOTE: Parts that are ordered with an "LF" suffix to the part number are the Pb-Free configuration and are RoHS compliant.

The aforementioned trademarks, HiPerClockS and FEMTOCLOCKS are trademarks of Integrated Circuit Systems, Inc. or its subsidiaries in the United States and/or other countries.

While the information presented herein has been checked for both accuracy and reliability, Integrated Circuit Systems, Incorporated (ICS) assumes no responsibility for either its use or for infringement of any patents or other rights of third parties, which would result from its use. No other circuits, patents, or licenses are implied. This product is intended for use in normal commercial and industrial applications. Any other applications such as those requiring high reliability or other extraordinary environmental requirements are not recommended without additional processing by ICS. ICS reserves the right to change any circuitry or specifications without notice. ICS does not authorize or warrant any ICS product for use in life support devices or critical medical instruments.