

Document No.	853-1499
ECN No.	00731
Date of Issue	October 17, 1990
Status	Product Specification
ACL Products	

AC11543: Preliminary Specification

ACT11543: Product Specification

Octal latched transceiver with dual enable (3-State)

FEATURES

- Combines '245 and '373 type functions in one chip
- 8-bit octal transceiver with D-type latch
- 3-State buffers
- Output capability: ± 24 mA
- CMOS (AC) and TTL (ACT) voltage level inputs
- 50 Ω incident wave switching
- Center-pin V_{CC} and ground configuration to minimize high-speed switching noise
- I_{CC} category: MSI

DESCRIPTION

The 74AC/ACT11543 high-performance CMOS devices combine very high speed and high output drive comparable to the most advanced TTL families.

The 74AC/ACT11543 Octal Latched Transceiver contains two sets of D-type latches for temporary storage of data flowing in either direction. Separate Latch Enable (LE_{AB} , LE_{BA}) and Output Enable (OE_{AB} , OE_{BA}) inputs are provided for each register to permit inde-

(continued)

QUICK REFERENCE DATA

SYMBOL	PARAMETER	CONDITIONS $T_{amb} = 25^{\circ}C$; GND = 0V; $V_{CC} = 5.0V$	TYPICAL		UNIT
			AC	ACT	
t_{PLH}/t_{PHL}	Propagation delay A_n to B_n or B_n to A_n	$C_L = 50pF$	5.5	6.4	ns
C_{PD}	Power dissipation capacitance per transceiver ¹	$f = 1MHz$; Enabled	45	47	pF
		$C_L = 50pF$; Disabled	10	13	
C_{IN}	Input capacitance	$V_I = 0V$ or V_{CC}	4.5	4.5	pF
C_{VO}	I/O capacitance	$V_{VO} = 0V$ or V_{CC} ; Disabled	12	12	pF
I_{LATCH}	Latch-up current	Per Jeduc JC40.2 Standard 17	500	500	mA

Note:

1. C_{PD} is used to determine the dynamic power dissipation (P_D in μW):

$$P_D = C_{PD} \times V_{CC}^2 \times f_I + \sum (C_L \times V_{CC}^2 \times f_O) \text{ where:}$$

f_I = input frequency in MHz, C_L = output load capacitance in pF,

f_O = output frequency in MHz, V_{CC} = supply voltage in V,

$\sum (C_L \times V_{CC}^2 \times f_O)$ = sum of outputs

ORDERING INFORMATION

PACKAGES	TEMPERATURE RANGE	ORDER CODE
28-pin plastic DIP (300mil-wide)	-40°C to +85°C	74AC11543N 74ACT11543N
28-pin plastic SOL (300mil-wide)	-40°C to +85°C	74AC11543D 74ACT11543D

PIN CONFIGURATION

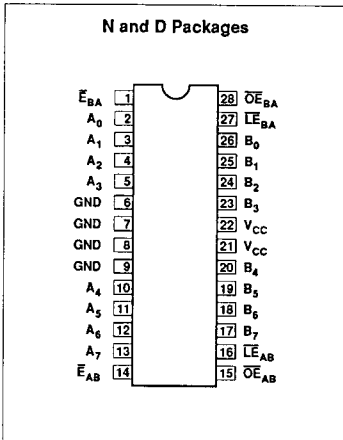

LOGIC SYMBOL

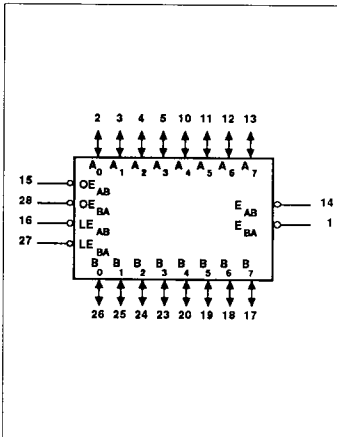

LOGIC SYMBOL (IEEE/IEC)

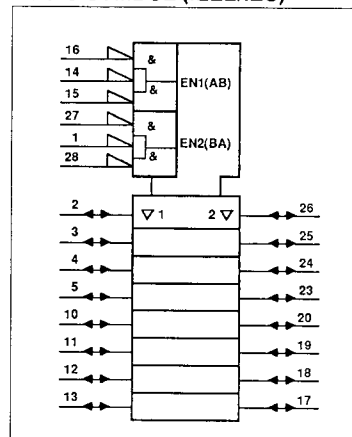

Octal latched transceiver with dual enable (3-State)

74AC/ACT11543

pendent control of inputting and outputting in either direction of data flow.

FUNCTIONAL DESCRIPTION

The 74AC/ACT11543 Octal Latched Transceiver contains two sets of eight D-type latches, with separate input and controls for each set. For data flow from A to B, for example, the A-to-B

Enable (\overline{E}_{AB}) input must be Low in order to enter data from $A_0 - A_7$ or take data from $B_0 - B_7$ as indicated in the Function Table. With \overline{E}_{AB} Low, a Low signal on the A-to-B Latch Enable (\overline{LE}_{AB}) input makes the A-to-B latches transparent; a subsequent Low-to-High transition of the \overline{LE}_{AB} signal puts the A latches in the storage mode and their

outputs no longer change with the A inputs. With \overline{E}_{AB} and \overline{OE}_{AB} both Low, the 3-State B output buffers are active and display the data present at the outputs of the A latches. Control of data flow from B to A is similar, but using the \overline{E}_{BA} , \overline{LE}_{BA} , and \overline{OE}_{BA} inputs.

PIN DESCRIPTION

PIN NUMBER	SYMBOL	NAME AND FUNCTION
15	\overline{OE}_{AB}	A-to-B output enable input (active Low)
28	\overline{OE}_{BA}	B-to-A output enable input (active Low)
16	\overline{LE}_{AB}	A-to-B latch enable input (active Low)
27	\overline{LE}_{BA}	B-to-A latch enable input (active Low)
14	\overline{E}_{AB}	A-to-B enable input (active Low)
1	\overline{E}_{BA}	B-to-A enable input (active Low)
2, 3, 4, 5, 10, 11, 12, 13	$A_0 - A_7$	Data inputs/outputs (A side)
26, 25, 24, 23, 20, 19, 18, 17	$B_0 - B_7$	Data inputs/outputs (B side)
6, 7, 8, 9	GND	Ground (0V)
21, 22	V_{CC}	Positive supply voltage

FUNCTION TABLE

INPUTS				OUTPUTS	STATUS
\overline{OE}_{xx}	\overline{E}_{xx}	\overline{LE}_{xx}	Data		
H	X	X	X	Z	Outputs disabled
X	H	X	X	Z	Outputs disabled
L	↑	L	h	Z	Diasabled + latched
L	↑	L	l	Z	
L	L	↑	h	H	Latch + display
L	L	↑	l	L	
L	L	L	H	H	Transparent
L	L	L	L	L	
L	L	H	X	NC	Hold

H = High voltage level

h = High state must be present one setup time before the Low-to-High transition of \overline{LE}_{xx} or \overline{E}_{xx} (XX = AB or BA)

L = Low voltage level

l = Low state must be present one setup time before the Low-to-High transition of \overline{LE}_{xx} or \overline{E}_{xx} (XX = AB or BA)

↑ = Low-to-High transition of \overline{LE}_{xx} or \overline{E}_{xx} (XX = AB or BA)

X = Don't care

NC = No change

Z = High-impedance state

Octal latched transceiver with dual enable (3-State)

74AC/ACT11543

LOGIC DIAGRAM

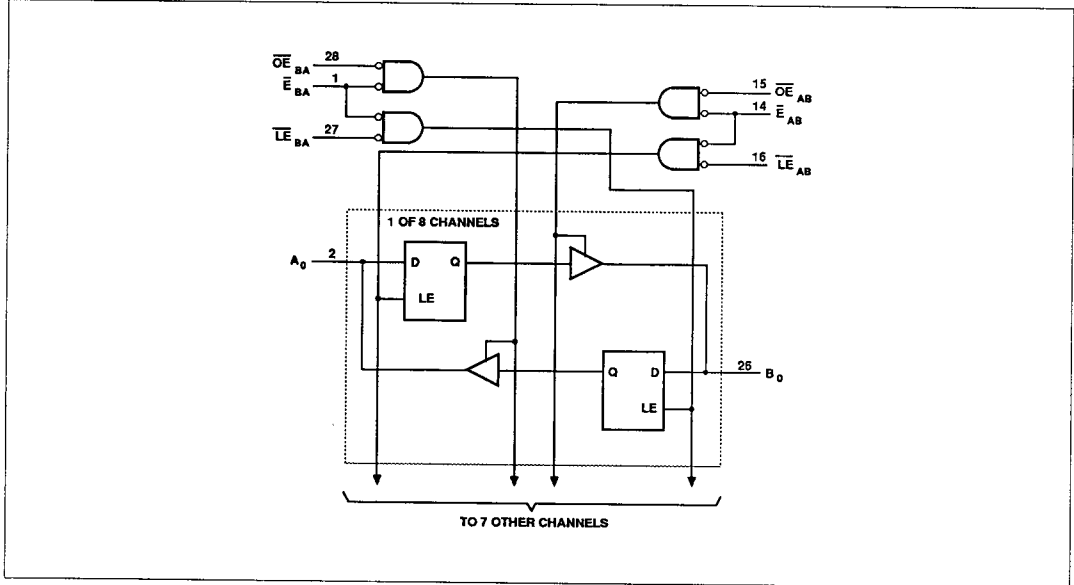

Octal latched transceiver with dual enable (3-State)

74AC/ACT11543

RECOMMENDED OPERATING CONDITIONS

SYMBOL	PARAMETER	74AC11543			74ACT11543			UNIT
		Min	Nom	Max	Min	Nom	Max	
V_{CC}	DC supply voltage	3.0 ¹	5.0	5.5	4.5	5.0	5.5	V
V_I	Input voltage	0		V_{CC}	0		V_{CC}	V
V_O	Output voltage	0		V_{CC}	0		V_{CC}	V
$\Delta t/\Delta v$	Input transition rise or fall rate	0		10	0		10	ns/V
T_{amb}	Operating free-air temperature range	-40		+85	-40		+85	°C

NOTE:

- No electrical or switching characteristics are specified at $V_{CC} < 3V$. Operation between 2V and 3V is not recommended, but within that range, a device output will maintain a previously established logic state.

ABSOLUTE MAXIMUM RATINGS¹

SYMBOL	PARAMETER	TEST CONDITIONS	RATING	UNIT
V_{CC}	DC supply voltage		-0.5 TO +7.0	V
I_{IK} or V_I	DC input diode current ²	$V_I < 0$	-20	mA
		$V_I > V_{CC}$	20	
	DC input voltage		-0.5 to $V_{CC} + 0.5$	V
I_{OK} or V_O	DC output diode current ²	$V_O < 0$	-50	mA
		$V_O > V_{CC}$	50	
	DC output voltage		-0.5 to $V_{CC} + 0.5$	V
I_O	DC output source or sink current per output pin	$V_O = 0$ to V_{CC}	±50	mA
I_{CC} or I_{GND}	DC V_{CC} current		±400	mA
	DC ground current		±400	
T_{STG}	Storage temperature		-65 to 150	°C
P_{TOT}	Power dissipation per package	Above 70°C; derate linearly by 8mW/K	500	mW
	Power dissipation per package Plastic surface mount (SO)	Above 70°C; derate linearly by 8mW/K	400	mW

NOTES:

- Stresses beyond those listed may cause permanent damage to the device. These are stress ratings only and functional operation of the device at these or any other conditions beyond those indicated under "recommended operating conditions" is not implied. Exposure to absolute-maximum-rated conditions for extended periods may affect device reliability.
- The input and output voltage ratings may be exceeded if the input and output current ratings are observed.

Octal latched transceiver with dual enable (3-State)

74AC/ACT11543

DC ELECTRICAL CHARACTERISTICS

SYMBOL	PARAMETER	TEST CONDITIONS	V _{CC} V	74AC11543				74ACT11543				UNIT	
				T _{amb} = +25°C		T _{amb} = -40°C to +85°C		T _{amb} = +25°C		T _{amb} = -40°C to +85°C			
				Min	Max	Min	Max	Min	Max	Min	Max		
V _{IH}	High-level input voltage		3.0	2.10		2.10						V	
			4.5	3.15		3.15		2.0		2.0			
			5.5	3.85		3.85		2.0		2.0			
V _{IL}	Low-level input voltage		3.0		0.90		0.90					V	
			4.5		1.35		1.35		0.8		0.8		
			5.5		1.65		1.65		0.8		0.8		
V _{OH}	High-level output voltage	V _I = V _{IL} or V _{IH}	I _{OH} = -50μA	3.0	2.9		2.9					V	
				4.5	4.4		4.4		4.4		4.4		
				5.5	5.4		5.4		5.4		5.4		
			I _{OH} = -4mA	3.0	2.58		2.48						
				4.5	3.94		3.8		3.94		3.8		
				5.5	4.94		4.8		4.94		4.8		
I _{OH} = -75mA ¹	3.0			3.85				3.85					
	5.5												
V _{OL}	Low-level output voltage	V _I = V _{IL} or V _{IH}	I _{OL} = 50μA	3.0		0.1		0.1				V	
				4.5		0.1		0.1		0.1			0.1
				5.5		0.1		0.1		0.1			0.1
			I _{OL} = 12mA	3.0		0.36		0.44					
				4.5		0.36		0.44		0.36			0.44
				5.5		0.36		0.44		0.36			0.44
			I _{OL} = 24mA	3.0				1.65					1.65
				5.5									
I _{OL} = 75mA ¹	3.0				1.65				1.65				
	5.5												
I _I	Input leakage current	V _I = V _{CC} or GND	5.5		±0.1		±1.0		±0.1		±1.0	μA	
I _{OZ}	3-State output off-state current	V _I = V _{IL} or V _{IH} , V _O = V _{CC} or GND	5.5		±0.5		5.0		±0.5		5.0	μA	
I _{CC}	Quiescent supply current	V _I = V _{CC} or GND, I _O = 0mA	5.5		8.0		80		8.0		80	μA	
ΔI _{CC}	Supply current, TTL inputs High ²	One input at 3.4V, other inputs at V _{CC} or GND	5.5						0.9		1.0	mA	

NOTES:

- Not more than one output should be tested at a time, and the duration of the test should not exceed 10ms.
- This is the increase in supply current for each input that is at one of the specified TTL voltage levels rather than 0V or V_{CC}.

Octal latched transceiver with dual enable (3-State)

74AC/ACT11543

AC ELECTRICAL CHARACTERISTICS AT 3.3V \pm 0.3V

SYMBOL	PARAMETER	WAVEFORM	74AC11543					UNIT
			T _{amb} = +25°C			T _{amb} = -40°C to +85°C		
			Min	Typ	Max	Min	Max	
t _{PLH} t _{PHL}	Propagation delay A _n to B _n or B _n to A _n	1	2.9 4.0	7.6 8.8	9.2 10.6	2.9 4.0	10.4 11.9	ns
t _{PLH} t _{PHL}	Propagation delay \overline{LE}_{BA} to A _n or \overline{LE}_{AB} to B _n	2	3.5 4.3	8.8 9.7	10.7 12.0	3.5 4.3	12.0 13.5	ns
t _{PZH} t _{PZL}	Output enable time \overline{OE}_{BA} to A _n or \overline{OE}_{AB} to B _n	3	3.6 5.2	8.7 10.4	10.4 12.8	3.6 5.2	11.6 15.5	ns
t _{PZH} t _{PZL}	Output enable time \overline{E}_{BA} to A _n or \overline{E}_{AB} to B _n	3	4.1 5.7	9.6 11.3	11.4 14.1	4.1 5.7	12.7 16.7	ns
t _{PHZ} t _{PLZ}	Output disable time \overline{OE}_{BA} to A _n or \overline{OE}_{AB} to B _n	3	3.8 4.0	6.9 6.9	8.6 8.5	3.8 4.0	9.3 9.1	ns
t _{PHZ} t _{PLZ}	Output disable time \overline{E}_{BA} to A _n or \overline{E}_{AB} to B _n	3	4.3 4.3	7.7 7.6	9.4 9.8	4.3 4.3	10.1 10.4	ns
t _S	Setup time, High or Low A _n to \overline{LE}_{AB} or B _n to \overline{LE}_{BA}	4	3.0			3.0		ns
t _H	Hold time, High or Low \overline{LE}_{AB} to A _n or \overline{LE}_{BA} to B _n	4	0.5			0.5		ns
t _S	Setup time, High or Low A _n to \overline{E}_{AB} or B _n to \overline{E}_{BA}	4	3.5			3.5		ns
t _H	Hold time, High or Low \overline{E}_{AB} to A _n or \overline{E}_{BA} to B _n	4	0.0			0.0		ns
t _W	Latch enable pulse width Low	2	400			4.0		ns

Octal latched transceiver with dual enable (3-State)

74AC/ACT11543

AC ELECTRICAL CHARACTERISTICS AT 5.0V \pm 0.5V

SYMBOL	PARAMETER	WAVEFORM	74AC11543					UNIT
			$T_{amb} = +25^{\circ}\text{C}$			$T_{amb} = -40^{\circ}\text{C to } +85^{\circ}\text{C}$		
			Min	Typ	Max	Min	Max	
t_{PLH} t_{PHL}	Propagation delay A_n to B_n or B_n to A_n	1	2.3 3.3	4.8 6.1	6.8 8.0	2.3 3.3	7.5 8.9	ns
t_{PLH} t_{PHL}	Propagation delay \overline{LE}_{BA} to A_n or \overline{LE}_{AB} to B_n	2	3.0 3.7	5.6 6.6	7.6 8.9	3.0 3.7	8.4 9.9	ns
t_{PZH} t_{PZL}	Output enable time \overline{OE}_{BA} to A_n or \overline{OE}_{AB} to B_n	3	3.1 4.4	5.7 7.7	7.6 9.9	3.1 4.4	8.3 11.2	ns
t_{PZH} t_{PZL}	Output enable time \overline{E}_{BA} to A_n or \overline{E}_{AB} to B_n	3	3.6 4.9	6.2 8.3	8.3 10.6	3.6 4.9	9.1 12.0	ns
t_{PHZ} t_{PLZ}	Output disable time \overline{OE}_{BA} to A_n or \overline{OE}_{AB} to B_n	3	3.5 3.6	5.5 5.5	7.2 7.3	3.5 3.6	7.7 7.7	ns
t_{PHZ} t_{PLZ}	Output disable time \overline{E}_{BA} to A_n or \overline{E}_{AB} to B_n	3	3.9 4.0	6.0 6.0	7.7 8.1	3.9 4.0	8.3 8.5	ns
t_S	Setup time, High or Low A_n to \overline{LE}_{AB} or B_n to \overline{LE}_{BA}	4	2.0			2.0		ns
t_H	Hold time, High or Low \overline{LE}_{AB} to A_n or \overline{LE}_{BA} to B_n	4	1.0			1.0		ns
t_S	Setup time, High or Low A_n to \overline{E}_{AB} or B_n to \overline{E}_{BA}	4	2.5			2.5		ns
t_H	Hold time, High or Low \overline{E}_{AB} to A_n or \overline{E}_{BA} to B_n	4	0.5			0.5		ns
t_W	Latch enable pulse width Low	2	4.0			4.0		ns

Octal latched transceiver with dual enable (3-State)

74AC/ACT11543

AC ELECTRICAL CHARACTERISTICS AT 5.0V ±0.5V

SYMBOL	PARAMETER	WAVEFORM	74ACT11543					UNIT
			T _{amb} = +25°C			T _{amb} = -40°C to +85°C		
			Min	Typ	Max	Min	Max	
t _{PLH} t _{PHL}	Propagation delay A _n to B _n or B _n to A _n	1	3.5 3.2	6.2 6.5	9.1 10.8	3.5 3.2	10.2 12.1	ns
t _{PLH} t _{PHL}	Propagation delay \overline{LE}_{BA} to A _n or \overline{LE}_{AB} to B _n	2	3.0 3.7	6.1 7.2	10.1 11.7	3.0 3.7	11.2 13.2	ns
t _{PZH} t _{PZL}	Output enable time \overline{OE}_{BA} to A _n or \overline{OE}_{AB} to B _n	3	3.3 3.0	6.4 8.0	10.5 12.8	3.3 3.0	11.5 15.3	ns
t _{PZH} t _{PZL}	Output enable time \overline{E}_{BA} to A _n or \overline{E}_{AB} to B _n	3	3.5 3.2	6.7 8.4	11.1 13.4	3.5 3.2	12.2 16.0	ns
t _{PHZ} t _{PLZ}	Output disable time \overline{OE}_{BA} to A _n or \overline{OE}_{AB} to B _n	3	4.6 5.0	6.9 7.1	9.6 9.8	4.6 5.0	10.4 10.5	ns
t _{PHZ} t _{PLZ}	Output disable time \overline{E}_{BA} to A _n or \overline{E}_{AB} to B _n	3	4.8 5.1	7.3 7.5	10.1 10.3	4.8 5.1	11.0 11.1	ns
t _S	Setup time, High or Low A _n to \overline{LE}_{AB} or B _n to \overline{LE}_{BA}	4	2.5			2.5		ns
t _H	Hold time, High or Low \overline{LE}_{AB} to A _n or \overline{LE}_{BA} to B _n	4	2.0			2.0		ns
t _S	Setup time, High or Low A _n to \overline{E}_{AB} or B _n to \overline{E}_{BA}	4	3.0			3.0		ns
t _H	Hold time, High or Low \overline{E}_{AB} to A _n or \overline{E}_{BA} to B _n	4	1.5			1.5		ns
t _W	Latch enable pulse width Low	2	4.0			4.0		ns

AC WAVEFORMS

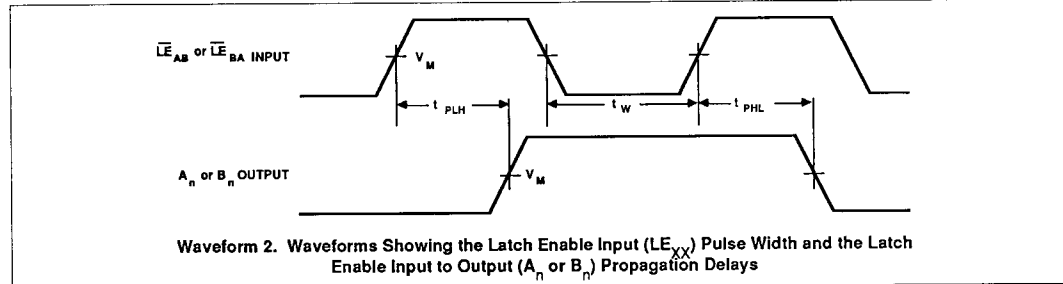
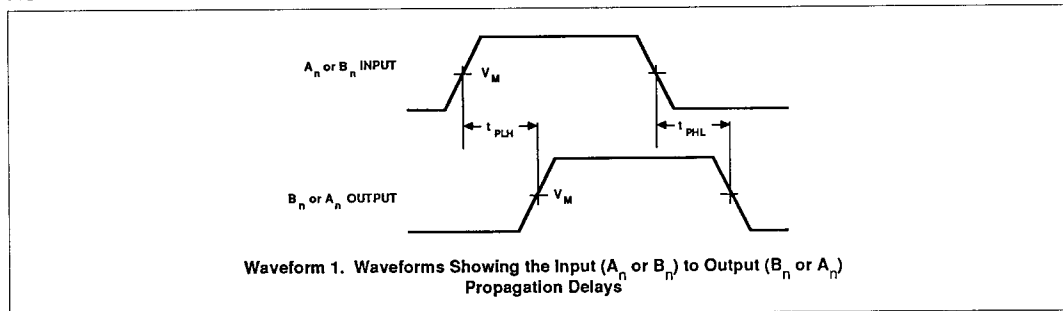

Octal latched transceiver with dual enable (3-State)

74AC/ACT11543

AC WAVEFORMS (Continued)

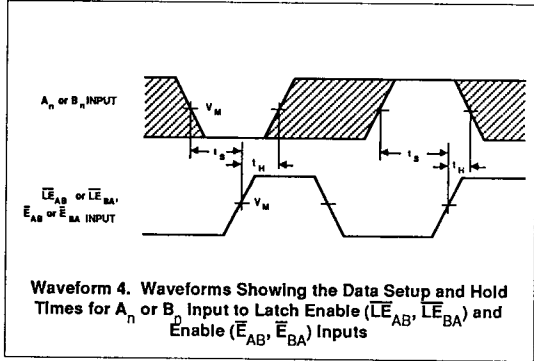
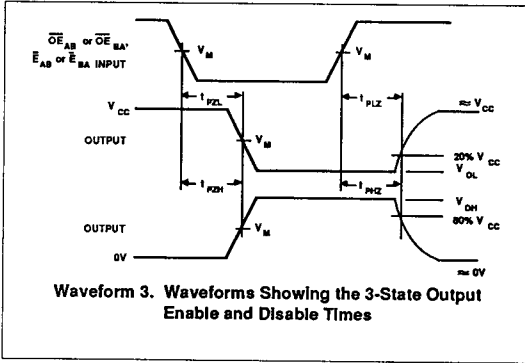

WAVEFORM CONDITIONS

	INPUTS	OUTPUTS
AC	$V_{IN} = \text{GND to } V_{CC}$ $V_M = 50\% V_{CC}$	$V_{OUT} = V_{OL} \text{ to } V_{OH}$ $V_M = 50\% V_{CC}$
ACT	$V_{IN} = \text{GND to } 3.0V$ $V_M = 1.5V$	

TEST CIRCUIT

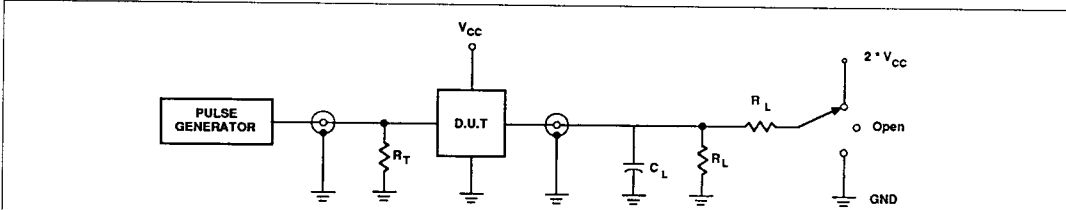

Test Circuit

TEST	S1
t_{PLH}/t_{PHL}	Open
t_{PLZ}/t_{PZL}	$2 \cdot V_{CC}$
t_{PHZ}/t_{PZH}	GND

SWITCH POSITION

DEFINITIONS

C_L = Load capacitance, 50pF; includes jig and probe capacitance
 R_L = Load resistor, 500Ω
 R_T = Termination resistance should be equal to Z_{OUT} of pulse generators
 Input pulses: PRR ≤ 10MHz
 $t_r = t_f = 3ns$