

Temperature Transducer

FEATURES

- Linear current output: $1 \mu\text{A}/^\circ\text{K}$
- Wide range: -55°C to $+150^\circ\text{C}$
- Two-terminal device: Voltage in/current out
- Laser trimmed to $\pm 0.5^\circ\text{C}$ calibration accuracy (AD590M)
- Excellent linearity: $\pm 0.5^\circ\text{C}$ over full range (AD590M)
- Wide power supply range: $+4\text{V}$ to $+30\text{V}$
- Sensor isolation from case
- Low cost

GENERAL DESCRIPTION

The AD590 is an integrated-circuit temperature transducer which produces an output current proportional to absolute temperature. The device acts as a high impedance constant current regulator, passing $1 \mu\text{A}/^\circ\text{K}$ for supply voltages between $+4\text{V}$ and $+30\text{V}$. Laser trimming of the chip's thin film resistors is used to calibrate the device to $298.2 \mu\text{A}$ output at 298.2°K ($+25^\circ\text{C}$).

The AD590 should be used in any temperature-sensing application between -55°C and $+150^\circ\text{C}$ (0°C and 70°C for TO-92)

in which conventional electrical temperature sensors are currently employed. The inherent low cost of a monolithic integrated circuit combined with the elimination of support circuitry makes the AD590 an attractive alternative for many temperature measurement situations. Linearization circuitry, precision voltage amplifiers, resistance-measuring circuitry and cold-junction compensation are not needed in applying the AD590. In the simplest application, a resistor, a power source and any voltmeter can be used to measure temperature.

In addition to temperature measurement, applications include temperature compensation or correction of discrete components, and biasing proportional to absolute temperature. The AD590 is available in chip form making it suitable for hybrid circuits and fast temperature measurements in protected environments.

The AD590 is particularly useful in remote sensing applications. The device is insensitive to voltage drops over long lines due to its high-impedance current output. Any well-insulated twisted pair is sufficient for operation hundreds of feet from the receiving circuitry. The output characteristics also make the AD590 easy to multiplex: the current can be switched by a CMOS multiplexer or the supply voltage can be switched by a logic gate output.

5

SCHEMATIC DIAGRAM

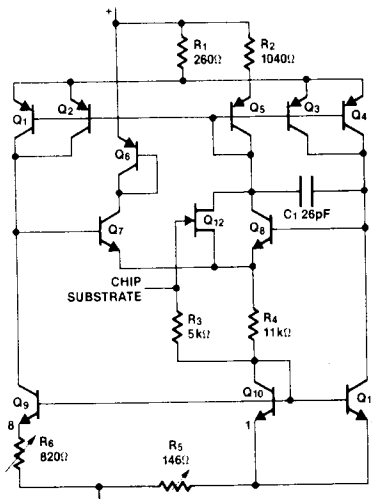

PIN CONFIGURATIONS

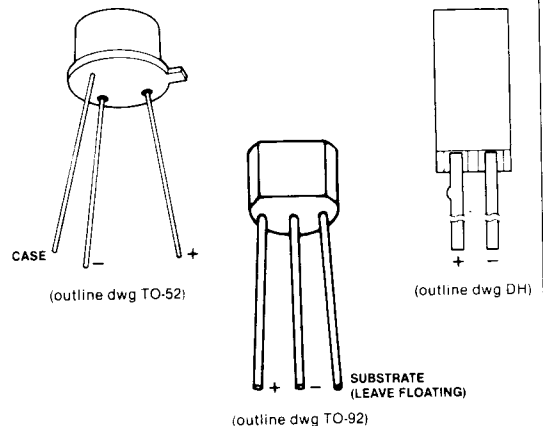

ORDERING INFORMATION

TO-52 and Ceramic Package:
Operate -55°C to $+150^\circ\text{C}$
TO-92:
Operate 0°C to $+70^\circ\text{C}$

NON-LINEARITY ($^\circ\text{C}$)	TO-52 PACKAGE	CERAMIC PACKAGE	TO-92 PACKAGE
± 3.0	AD590IH	AD590IF	AD590IZR
± 1.5	AD590JH	AD590JF	AD590JZR
± 0.8	AD590KH	AD590KF	AD590KZR
± 0.4	AD590LH	AD590LF	—
± 0.3	AD590MH	AD590MF	—

ABSOLUTE MAXIMUM RATINGS ($T_A = +25^\circ\text{C}$ unless otherwise noted)

Forward Voltage (V^+ to V^-)	+ 44V	Rated Performance Temperature Range	
Reverse Voltage (V^+ to V^-)	- 20V	TO-92	.0°C to + 70°C
Breakdown Voltage (Case to V^+ or V^-)	± 200V	TO-52, Ceramic	- 55°C to + 150°C
Storage Temperature Range	- 65°C to + 175°C	Lead Temperature (Soldering, 10 sec.)	+ 300°C

Stresses above those listed under "Absolute Maximum Ratings" may cause permanent damage to the device. These are stress ratings only and functional operation of the device at these or any other conditions above those indicated in the operational sections of the specifications is not implied. Exposure to absolute maximum rating conditions for extended periods may affect device reliability.

SPECIFICATIONS (Typical values at $T_A = +25^\circ\text{C}$, $V^+ = 5\text{V}$ unless otherwise noted)

CHARACTERISTICS	AD590I	AD590J	AD590K	AD590L	AD590M	UNITS
Output						
Nominal Output Current @ + 25°C (298.2°K)	298.2	298.2	298.2	298.2	298.2	μA
Nominal Temperature Coefficient	1.0	1.0	1.0	1.0	1.0	μA/°K
Calibration Error @ + 25°C (Notes)	± 10.0 max	± 5.0 max	± 2.5 max	± 1.0 max	± 0.5 max	°C
Absolute Error (- 55°C to + 150°C)						
Without External Calibration Adjustment	± 20.0 max	± 10.0 max	± 5.5 max	± 3.0 max	± 1.7 max	°C
With External Calibration Adjustment	± 5.8 max	± 3.0 max	± 2.0 max	± 1.6 max	± 1.0 max	°C
Non-Linearity	± 3.0 max	± 1.5 max	± 0.8 max	± 0.4 max	± 0.3 max	°C
Repeatability (Note 2)	± 0.1 max	± 0.1 max	± 0.1 max	± 0.1 max	± 0.1 max	°C
Long Term Drift (Note 3)	± 0.1 max	± 0.1 max	± 0.1 max	± 0.1 max	± 0.1 max	°C/month
Current Noise	40	40	40	40	40	pA/√Hz
Power Supply Rejection						
+ 4 < V^+ < + 5V	0.5	0.5	0.5	0.5	0.5	μA/V
+ 5 < V^+ < + 15V	0.2	0.2	0.2	0.2	0.2	μA/V
+ 15V < V^+ < + 30V	0.1	0.1	0.1	0.1	0.1	μA/V
Case Isolation to Either Lead	10 ¹⁰	10 ¹⁰	10 ¹⁰	10 ¹⁰	10 ¹⁰	Ω
Effective Shunt Capacitance	100	100	100	100	100	pF
Electrical Turn-On Time (Note 1)	20	20	20	20	20	μs
Reverse Bias Leakage Current (Note 4)	10	10	10	10	10	pA
Power Supply Range	+ 4 to + 30	+ 4 to + 30	+ 4 to + 30	+ 4 to + 30	+ 4 to + 30	V

- Notes**
- Does not include self heating effects.
 - Maximum deviation between + 25°C reading after temperature cycling between - 55°C and + 150°C (0°C and 70°C for TO-92).
 - Conditions: Constant + 5V, constant + 125°C.
 - Leakage current doubles every + 10°C.
 - Mechanical strain on package (especially TO-92) may disturb calibration of device.

5

TRIMMING OUT ERRORS

The ideal graph current vs temperature for the AD590 is a straight line, but as Figure 1 shows, the actual shape is slightly different. Since the sensor is limited to the range of -55°C to +150°C (0°C to 70°C for TO-92), it is possible to optimize the accuracy by trimming. Trimming also permits extracting maximum performance from the lower-cost sensors.

The circuit of Figure 2 trims the slope of the AD590 output. The effect of this is shown in Figure 3.

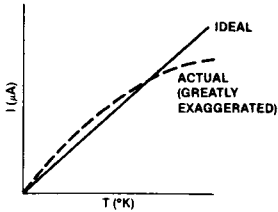

Figure 1. Trimming Out Errors

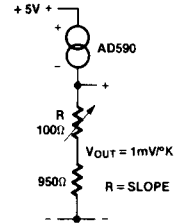

Figure 2. Slope Trimming

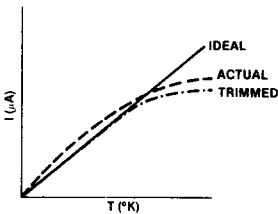

Figure 3. Effect of Slope Trim

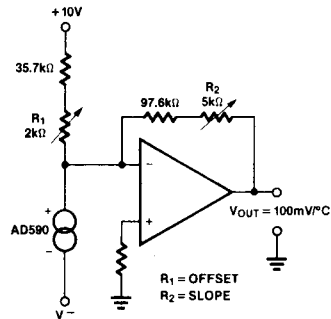

Figure 4. Slope and Offset Trimming

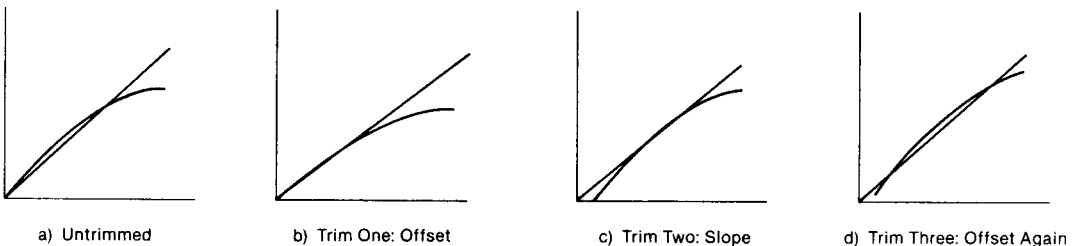

Figure 5. Effect of Slope and Offset Trimming

ACCURACY

Maximum errors over limited temperature spans, with $V_S = +5V$, are listed by device grade in the following tables. The tables reflect the worst-case linearities, which invariably occur at the extremities of the specified temperature range. The trimming conditions for the data in the tables are shown in Figures 2 and 3.

All errors listed in the tables are \pm °C. For example, if $\pm 1^\circ C$ maximum error is required over the $+25^\circ C$ to $+75^\circ C$ range (i.e., lowest temperature of $+25^\circ C$ and span of $50^\circ C$), then

the trimming of a J-grade device, using the single-trim circuit (Figure 2), will result in output having the required accuracy over the stated range. An M-grade device with no trims will have less than $\pm 0.9^\circ C$ error, and an I-grade device with two trims (Figure 3) will have less than $\pm 0.2^\circ$ error. If the requirement is for less than $\pm 1.4^\circ C$ maximum error, from $-25^\circ C$ to $+75^\circ C$ (100° span from $-25^\circ C$), it can be satisfied by an M-grade device with no trims, a K-grade device with one trim, or an I-grade device with two trims.

I GRADE—MAXIMUM ERRORS, °C

NUMBER OF TRIMS	TEMPERATURE SPAN—°C	LOWEST TEMPERATURE IN SPAN—°C							
		-55	-25	0	+25	+50	+75	+100	+125
None	10	8.4	9.2	10.0	10.8	11.6	12.4	13.2	14.4
None	25	10.0	10.4	11.0	11.8	12.0	13.8	15.0	16.0
None	50	13.0	13.0	12.8	13.8	14.6	16.4	18.0	
None	100	15.2	16.0	16.6	17.4	18.8			
None	150	18.4	19.0	19.2					
None	205	20.0							
One	10	0.6	0.4	0.4	0.4	0.4	0.4	0.4	0.6
One	25	1.8	1.2	1.0	1.0	1.0	1.2	1.6	1.8
One	50	3.8	3.0	2.0	2.0	2.0	3.0	3.8	
One	100	4.8	4.5	4.2	4.2	5.0			
One	150	5.5	4.8	5.5					
One	205	5.8							
Two	10	0.3	0.2	0.1	<	<	0.1	0.2	0.3
Two	25	0.5	0.3	0.2	<	0.1	0.2	0.3	0.5
Two	50	1.2	0.6	0.4	0.2	0.2	0.3	0.7	
Two	100	1.8	1.4	1.0	2.0	2.5			
Two	150	2.6	2.0	2.8					
Two	205	3.0							

<: Less than 0.05°C.

J GRADE—MAXIMUM ERRORS, °C

NUMBER OF TRIMS	TEMPERATURE SPAN—°C	LOWEST TEMPERATURE IN SPAN—°C							
		-55	-25	0	+25	+50	+75	+100	+125
None	10	4.2	4.6	5.0	5.4	5.8	6.2	6.6	7.2
None	25	5.0	5.2	5.5	5.9	6.0	6.9	7.5	8.0
None	50	6.5	6.5	6.4	6.9	7.3	8.2	9.0	
None	100	7.7	8.0	8.3	8.7	9.4			
None	150	9.2	9.5	9.6					
None	205	10.0							
One	10	0.3	0.2	0.2	0.2	0.2	0.2	0.2	0.3
One	25	0.9	0.6	0.5	0.5	0.5	0.6	0.8	0.9
One	50	1.9	1.5	1.0	1.0	1.0	1.5	1.9	
One	100	2.3	2.2	2.0	2.0	2.3			
One	150	2.5	2.4	2.5					
One	205	3.0							
Two	10	0.1	<	<	<	<	<	<	0.1
Two	25	0.2	0.1	<	<	<	<	0.1	0.2
Two	50	0.4	0.2	0.1	<	<	0.1	0.2	<
Two	100	0.7	0.5	0.3	0.7	1.0			
Two	150	1.0	0.7	1.2					
Two	205	1.6							

<: Less than $\pm 0.05^\circ C$.

5

K GRADE—MAXIMUM ERRORS, °C

NUMBER OF TRIMS	TEMPERATURE SPAN—°C	LOWEST TEMPERATURE IN SPAN—°C							
		-55	-25	0	+25	+50	+75	+100	+125
None	10	2.1	2.3	2.5	2.7	2.9	3.1	3.3	3.6
None	25	2.6	2.7	2.8	3.0	3.2	3.5	3.8	4.2
None	50	3.8	3.5	3.4	3.6	3.8	4.3	5.1	
None	100	4.2	4.3	4.4	4.6	5.1			
None	150	4.8	4.8	5.3					
None	205	5.5							
One	10	0.2	0.1	0.1	0.1	0.1	0.1	0.1	0.2
One	25	0.6	0.4	0.3	0.3	0.3	0.4	0.5	0.6
One	50	1.2	1.0	0.7	0.7	0.7	1.0	1.2	
One	100	1.5	1.4	1.3	1.3	1.5			
One	150	1.7	1.5	1.7					
One	205	2.0							
Two	10	0.1	<	<	<	<	<	<	0.1
Two	25	0.2	0.1	<	<	<	<	0.1	0.2
Two	50	0.3	0.1	<	<	<	0.1	0.2	
Two	100	0.5	0.3	0.2	0.3	0.7			
Two	150	0.6	0.5	0.7					
Two	205	0.8							

<: Less than ±0.05°C.

5

L GRADE—MAXIMUM ERRORS, °C

NUMBER OF TRIMS	TEMPERATURE SPAN—°C	LOWEST TEMPERATURE IN SPAN—°C							
		-55	-25	0	+25	+50	+75	+100	+125
None	10	1.0	1.0	1.1	1.1	1.2	1.3	1.4	1.6
None	25	1.3	1.3	1.3	1.4	1.5	1.6	1.7	1.9
None	50	1.9	1.8	1.7	1.8	1.9	2.1	2.4	
None	100	2.4	2.4	2.4	2.4	2.7			
None	150	2.7	2.6	2.8					
None	205	3.0							
One	10	0.2	0.1	0.1	0.1	0.1	0.1	0.1	0.2
One	25	0.5	0.4	0.3	0.3	0.3	0.3	0.4	0.5
One	50	1.0	0.8	0.6	0.6	0.6	0.8	1.0	
One	100	1.3	1.2	1.1	1.1	1.3			
One	150	1.4	1.3	1.4					
One	205	1.6							
Two	10	0.1	<	<	<	<	<	<	0.1
Two	25	0.1	<	<	<	<	<	<	0.1
Two	50	0.2	<	<	<	<	<	0.2	
Two	100	0.3	0.2	0.1	0.2	0.3			
Two	150	0.3	0.2	0.3					
Two	205	0.4							

<: Less than ±0.05°C.

M GRADE—MAXIMUM ERRORS, °C

NUMBER OF TRIMS	TEMPERATURE SPAN—°C	LOWEST TEMPERATURE IN SPAN—°C							
		-55	-25	0	+25	+50	+75	+100	+125
None	10	0.6	0.5	0.6	0.6	0.7	0.7	0.7	0.9
None	25	0.8	0.8	0.7	0.7	0.8	0.8	1.0	1.1
None	50	1.0	0.9	0.8	0.9	0.9	1.1	1.2	
None	100	1.3	1.4	1.3	1.4	1.5			
None	150	1.5	1.6	1.6					
None	205	1.7							
One	10	0.2	0.1	0.1	0.1	0.1	0.1	0.1	0.2
One	25	0.4	0.3	0.2	0.2	0.2	0.2	0.3	0.4
One	50	0.5	0.4	0.3	0.3	0.3	0.4	0.5	
One	100	0.8	0.8	0.7	0.7	0.8			
One	150	0.9	0.9	0.9					
One	205	1.0							
Two	10	0.1	<	<	<	<	<	<	0.1
Two	25	0.1	<	<	<	<	<	<	0.1
Two	50	0.2	<	<	<	<	<	0.2	
Two	100	0.2	0.1	<	0.1	0.2			
Two	150	0.3	0.2	0.3					
Two	205	0.3							

<: Less than $\pm 0.05^\circ\text{C}$.

NOTES

- Maximum errors over all ranges are guaranteed based on the known behavior characteristic of the AD590.
- For one-trim accuracy specifications, the 205°C span is assumed to be trimmed at +25°C; for all other spans, it is assumed that the device is trimmed at the midpoint.
- For the 205°C span, it is assumed that the two-trim temperatures are in the vicinity of 0°C and +140°C; for all other spans, the specified trims are at the endpoints.
- In precision applications, the actual errors encountered are usually dependent upon sources of error which are often overlooked in error budgets. These typically include:
 - Trim error in the calibration technique used
 - Repeatability error
 - Long-term drift errors

Trim error is usually the largest error source. This error arises from such causes as poor thermal coupling between the device to be calibrated and the reference sensor; reference sensor errors; lack of adequate time for the device being calibrated to settle to the final temperature; radically different thermal resistances between the case and the surroundings ($R_{\theta CA}$) when trimming and when applying the device.

Repeatability errors arise from a strain hysteresis of the package. The magnitude of this error is solely a function of the magnitude of the temperature span over which the device is used. For example, thermal shocks between 0°C and 100°C involve extremely low hysteresis and result in repeatability errors of less than $\pm 0.05^\circ\text{C}$. When the thermal-shock excursion is widened to -55°C to +150°C, the device will typically exhibit a repeatability error of $\pm 0.05^\circ\text{C}$ (± 0.10 guaranteed maximum).

Long-term drift errors are related to the average operating temperature and the magnitude of the thermal shocks experienced by the device. Extended use of the AD590 at temperatures above 100°C typically results in long-term drift of $\pm 0.03^\circ\text{C}$ per month; the guaranteed maximum is $\pm 0.10^\circ\text{C}$ per month. Continuous operation at temperatures below 100°C induces no measurable drifts in the device. Besides the effects of operating temperature, the severity of thermal shocks incurred will also affect absolute stability. For thermal-shock excursions less than 100°C, the drift is difficult to measure ($< 0.03^\circ\text{C}$). However, for 200°C excursions, the device may drift by as much as $\pm 0.10^\circ\text{C}$ after twenty such shocks. If severe, quick shocks are necessary in the application of the device, realistic simulated life tests are recommended for a thorough evaluation of the error introduced by such shocks.

5

TYPICAL APPLICATIONS

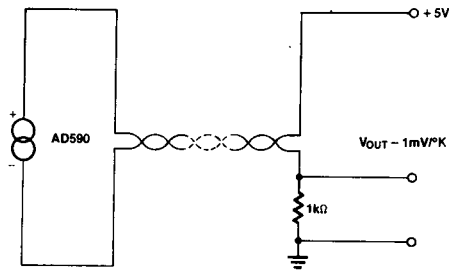
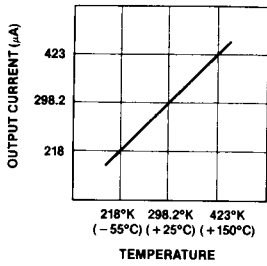

Figure 6. Simple connection. Output is proportional to absolute temperature.

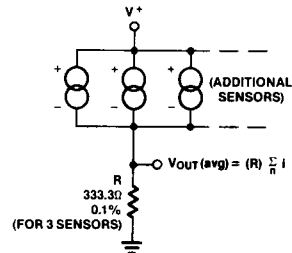
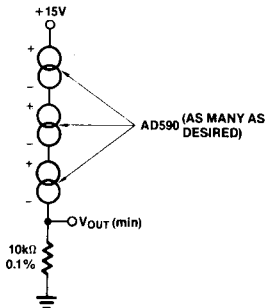

Figure 7. Lowest-temperature sensing scheme. Available current is that of the "coldest" sensor.

Figure 8. Average-temperature sensing scheme. The sum of the AD590 currents appears across R, which is chosen by the formula

$$R = \frac{10k\Omega}{n}$$

n being the number of sensors.

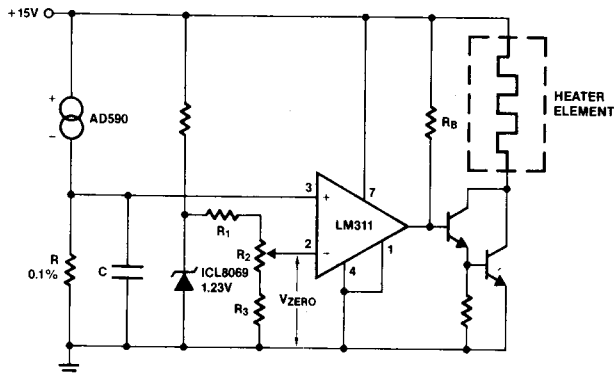

Figure 9. Single-setpoint temperature controller. The AD590 produces a temperature-dependent voltage across R (C is for filtering noise). Setting R₂ produces a scale-zero voltage. For the Celsius scale, make R=1kΩ and V_{ZERO}=0.273 volts. For Fahrenheit, R=1.8kΩ and V_{ZERO}=0.460 volts.

5

TYPICAL APPLICATIONS (Cont'd)

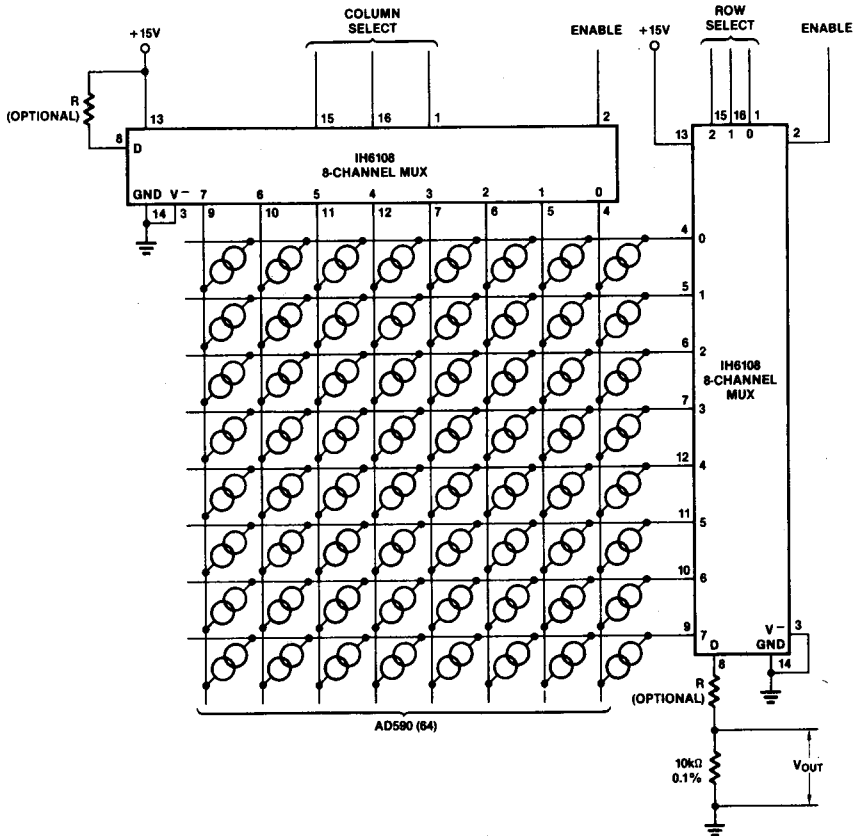

Figure 10. Multiplexing sensors. If shorted sensors are possible, a series resistor in series with the D line will limit the current (shown as R, above; only one is needed). A six-bit digital word will select one of 64 sensors.

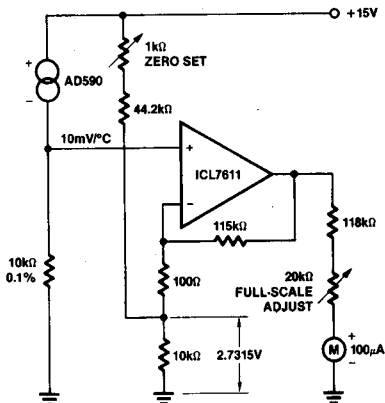

Figure 11. Centigrade thermometer (0°C–100°C). The ultra-low bias current of the ICL7611 allows the use of large-value gain-resistors, keeping meter-current error under 1/2%, and therefore saving the expense of an extra meter-driving amplifier.

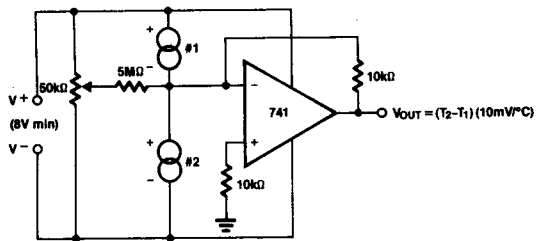

Figure 12. Differential thermometer. The 50kΩ pot trims offsets in the devices whether internal or external, so it can be used to set the size of the difference interval. This also makes it useful for liquid-level detection (where there will be a measurable temperature difference).

TYPICAL APPLICATIONS (Cont'd)

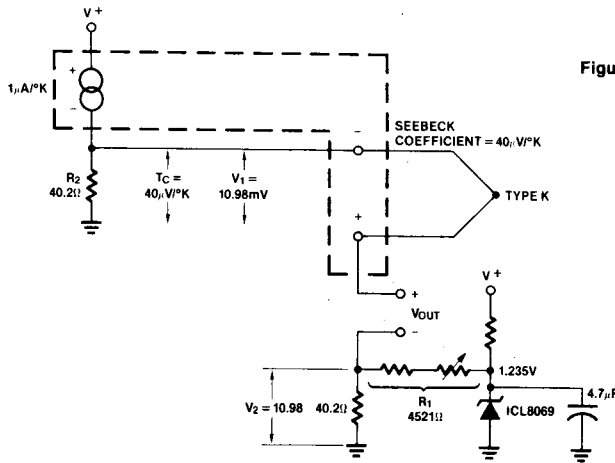

Figure 13. Cold-junction compensation for type K thermocouple.

The reference junction(s) should be in close thermal contact with the AD590 case. V^+ must be at least 4V, while ICL8069 current should be set at 1 mA-2 mA. Calibration does not require shorting or removal of the thermocouple: set R_1 for $V_2 = 10.98$ mV. If very precise measurements are needed, adjust R_2 to the exact Seebeck coefficient for the thermocouple used (measured or from table) note V_1 , and set R_1 to buck out this voltage (i.e., set $V_2 = V_1$). For other thermocouple types, adjust values to the appropriate Seebeck coefficient.

5

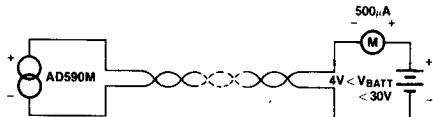
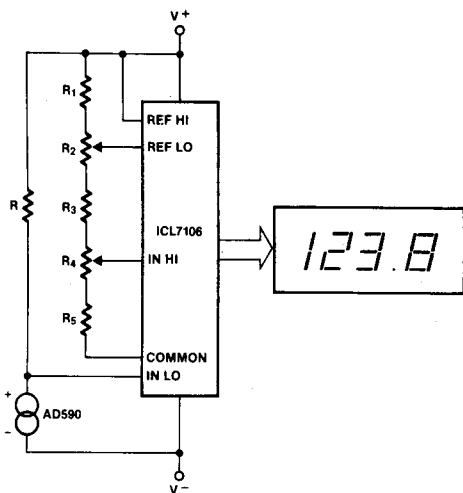

Figure 14. Simplest thermometer. Meter displays current output directly in degrees Kelvin. Using the AD590M, sensor output is within ± 1.7 degrees over the entire range, and less than ± 1 degree over the greater part of it.



	R	R ₁	R ₂	R ₃	R ₄	R ₅
°F	9.00	4.02	2.0	12.4	10.0	0
°C	5.00	4.02	2.0	5.11	5.0	11.8

$$\sum_{1}^5 R_n = 28\text{k}\Omega \text{ (nominal)}$$

All values in kΩ

The ICL7106 has a V_{IN} span of ± 2.0 V, and a V_{CM} range of $(V^+ - 0.5)$ Volts to $(V^- + 1)$ Volts; R is scaled to bring each range within V_{CM} while not exceeding V_{IN} . V_{REF} for both scales is 500mV. Maximum reading on the Celsius range is 199.9°C, limited by the (short-term) maximum allowable sensor temperature. Maximum reading on the Fahrenheit range is 199.9°F (93.3°C), limited by the number of display digits. See also note below.

Figure 15. Basic digital thermometer, Celsius and Fahrenheit scales

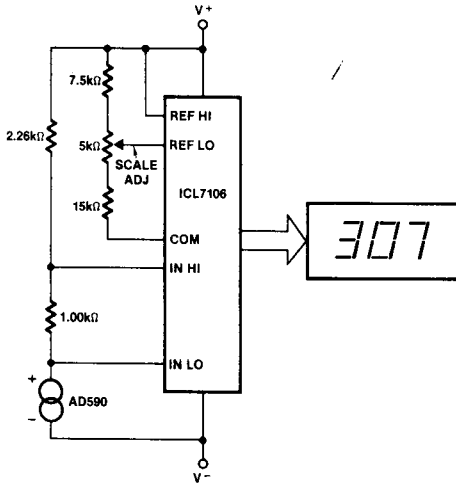

Figure 16. Basic digital thermometer, Kelvin scale. The Kelvin scale version reads from 0 to 1999°K theoretically, and from 223°K to 473°K actually. The 2.26kΩ resistor brings the input within the ICL7106 V_{CM} range: 2 general-purpose silicon diodes or an LED may be substituted.

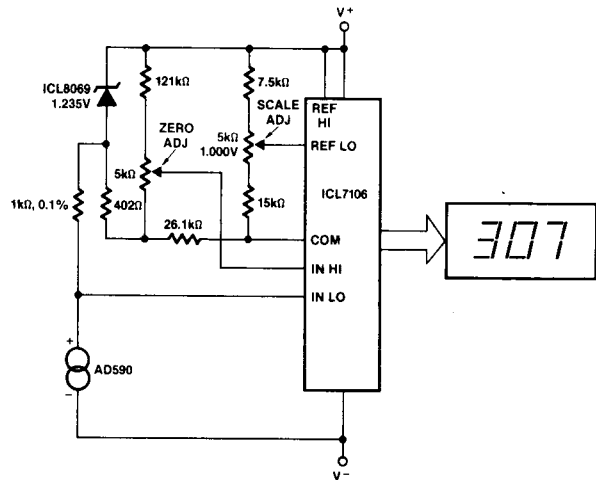

Figure 17. Basic digital thermometer, Kelvin scale with zero adjust. This circuit allows "zero adjustment" as well as slope adjustment. The ICL8069 brings the input within the common-mode range, while the 5kΩ pots trim any offset at 218°K (-55°C), and set scale factor.

Note on Figure 15, Figure 16 and Figure 17: Since all 3 scales have narrow V_{IN} spans, some optimization of ICL7106 components can be made to lower noise and preserve CMR. The table below shows the suggested values. Similar scaling can be used with the ICL7126/36.

Scale	V_{IN} Range (V)	R_{INT} (kΩ)	C_{AZ} (μF)
K	0.223 to 0.473	220	0.47
C	-0.25 to +1.0	220	0.1
F	-0.29 to +0.996	220	0.1

For all:

$C_{REF} = 0.1\mu F$

$C_{OSC} = 100pF$

$C_{INT} = 0.22\mu F$

$R_{OSC} = 100k\Omega$