

74VHC08 • 74VHCT08 Quad 2-Input AND Gate

General Description

The 74VHC/VHCT08 is an advanced high speed CMOS 2 Input AND Gate fabricated with silicon gate CMOS technology. It achieves the high-speed operation similar to equivalent Bipolar Schottky TTL while maintaining the CMOS low power dissipation.

The internal circuit is composed of 4 stages including buffer output, which provide high noise immunity and stable output. An input protection circuit insures that 0V to 7V can be applied to the input pins without regard to the supply voltage. This device can be used to interface 5V to 3V systems and two supply systems such as battery backup. This circuit prevents device destruction due to mismatched supply and input voltages.

Features

- High noise immunity:
VHC $V_{NIH} = V_{NIL} = 28\% V_{CC}$ (min)
VHCT $V_{IH} = 2.0V, V_{IL} = 0.8V$
 - Power down protection:
VHC inputs only
VHCT inputs and outputs
 - Low noise: $V_{OLP} = 0.8V$ (max)
 - Low power dissipation:
 $I_{CC} = 2 \mu A$ (Max) @ $T_A = 25^\circ C$
 - Balanced propagation delays: $t_{PLH} \approx t_{PHL}$
 - Pin and function compatible with 74HC/HCT08
- NOTE:** Add external pull up resistor to VHCT outputs to drive CMOS inputs

Ordering Code: See Section 6

Commercial	Package Number	Package Description
74VHC08M	M14A	14-Lead Molded JEDEC SOIC
74VHC08SJ	M14D	14-Lead Molded EIAJ SOIC
74VHC08MSC	MSC14	14-Lead Molded EIAJ Type 1 SSOP
74VHC08MTC	MTC14	14-Lead Molded JEDEC Type 1 TSSOP
74VHC08N	N14A	14-Lead Molded DIP
74VHCT08M	M14A	14-Lead Molded JEDEC SOIC
74VHCT08SJ	M14D	14-Lead Molded EIAJ SOIC
74VHCT08MTC	MTC14	14-Lead Molded JEDEC Type 1 TSSOP
74VHCT08N	N14A	14-Lead Molded DIP

Note: Surface mount packages are also available on Tape and Reel. Specify by appending the suffix letter "X" to the ordering code. EIAJ Type 1 SSOP available on a Tape and Reel only, order MSCX.

Logic Symbol

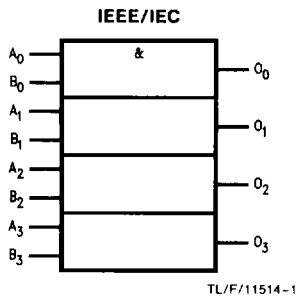

Connection Diagram

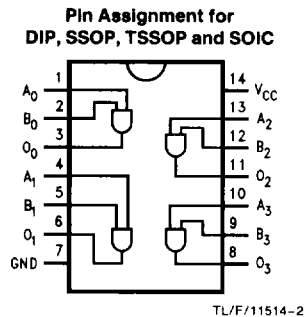

Pin Names	Description
A_n, B_n	Inputs
O_n	Outputs

Truth Table

A	B	O
L	L	L
L	H	L
H	L	L
H	H	H

Absolute Maximum Ratings (Note 1)

Supply Voltage (V_{CC})	-0.5V to +7.0V
DC Input Voltage (V_{IN})	-0.5V to +7.0V
DC Output Voltage (V_{OUT})	
VHC	-0.5V to $V_{CC} + 0.5V$
VHCT*	-0.5V to 7.0V
Input Diode Current (I_{IK})	-20 mA
Output Diode Current (I_{OK})	
VHC	±20 mA
VHCT	-20 mA
DC Output Current (I_{OUT})	±25 mA
DC V_{CC} /GND Current (I_{CC})	±50 mA
Storage Temperature (T_{STG})	-65°C to +150°C
Lead Temperature (T_L)	
(Soldering, 10 seconds)	260°C

* $V_{OUT} > V_{CC}$ only if output is in H state.

Note 1: *Absolute Maximum Ratings are values beyond which the device may be damaged or have its useful life impaired. The databook specifications should be met, without exception, to ensure that the system design is reliable over its power supply, temperature, and output/input loading variables. National does not recommend operation outside databook specifications.*

Recommended Operating Conditions

Supply Voltage (V_{CC})	
VHC	2.0V to +5.5V
VHCT	4.5V to 5.5V
Input Voltage (V_{IN})	0V to +5.5V
Output Voltage (V_{OUT})	0V to V_{CC}
Operating Temperature (T_{OPR})	-40°C to +85°C
Input Rise and Fall Time (t_r, t_f)	
$V_{CC} = 3.3V \pm 0.3V$ (VHC only)	0 ns/V ~ 100 ns/V
$V_{CC} = 5.0V \pm 0.5V$	0 ns/V ~ 20 ns/V

DC Characteristics for VHC Family Devices

Symbol	Parameter	V_{CC} (V)	74VHC			74VHC		Units	Conditions	
			$T_A = 25^\circ\text{C}$			$T_A = -40^\circ\text{C}$ to +85°C				
			Min	Typ	Max	Min	Max			
V_{IH}	High Level Input Voltage	2.0 3.0-5.5	1.50			1.50		V		
			0.7 V_{CC}			0.7 V_{CC}				
V_{IL}	Low Level Input Voltage	2.0 3.0-5.5			0.50		0.50	V		
			0.3 V_{CC}			0.3 V_{CC}				
V_{OH}	High Level Output Voltage	2.0	1.9	2.0		1.9		V	$V_{IN} = V_{IH}$ or V_{IL}	$I_{OH} = -50 \mu\text{A}$
		3.0	2.9	3.0		2.9				
		4.5	4.4	4.5		4.4				
		3.0	2.58			2.48		V		$I_{OH} = -4 \text{ mA}$ $I_{OH} = -8 \text{ mA}$
4.5	3.94			3.80						
V_{OL}	Low Level Output Voltage	2.0		0.0	0.1		0.1	V	$V_{IN} = V_{IH}$ or V_{IL}	$I_{OL} = 50 \mu\text{A}$
		3.0		0.0	0.1		0.1			
		4.5		0.0	0.1		0.1			
		3.0			0.36		0.44	V		$I_{OL} = 4 \text{ mA}$ $I_{OL} = 8 \text{ mA}$
4.5			0.36		0.44					
I_{IN}	Input Leakage Current	0-5.5			±0.1		±1.0	μA	$V_{IN} = 5.5V$ or GND	
I_{CC}	Quiescent Supply Current	5.5			2.0		20.0	μA	$V_{IN} = V_{CC}$ or GND	

DC Characteristics for 'VHC Family Devices: See Section 2 for Waveforms

Symbol	Parameter	V _{CC} (V)	74VHC		Units	Conditions	Fig. No.
			T _A = 25°C				
			Typ	Limits			
**V _{OLP}	Quiet Output Maximum Dynamic V _{OL}	5.0	0.3	0.8	V	C _L = 50 pF	2-11, 12
**V _{OLV}	Quiet Output Minimum Dynamic V _{OL}	5.0	-0.3	-0.8	V	C _L = 50 pF	2-11, 12
**V _{IHD}	Minimum High Level Dynamic Input Voltage	5.0		3.5	V	C _L = 50 pF	2-11, 12
**V _{ILD}	Maximum Low Level Dynamic Input Voltage	5.0		1.5	V	C _L = 50 pF	2-11, 12

**Parameter guaranteed by design.

DC Characteristics for 'VHCT Family Devices

Symbol	Parameter	V _{CC} (V)	74VHCT			74VHCT		Units	Conditions
			T _A = 25°C			T _A = -40°C to +85°C			
			Min	Typ	Max	Min	Max		
V _{IH}	High Level Input Voltage	4.5 5.5	2.0 2.0			2.0 2.0	V		
V _{IL}	Low Level Input Voltage	4.5 5.5			0.8 0.8	0.8 0.8	V		
V _{OH}	High Level Output Voltage	4.5	3.15	3.65		3.15	V	V _{IN} = V _{IH} I _{OH} = -50 μA	
		4.5	2.5			2.4	V	I _{OH} = -8 mA	
V _{OL}	Low Level Output Voltage	4.5		0.0	0.1		0.1	V	V _{IN} = V _{IH} I _{OL} = 50 μA
		4.5			0.36		0.44	V	I _{OL} = 8 mA
I _{IN}	Input Leakage Current	0-5.5			±0.1		±1.0	μA	V _{IN} = 5.5V or GND
I _{CC}	Quiescent Supply Current	5.5			2.0		20.0	μA	V _{IN} = V _{CC} or GND
I _{CC(T)}	Maximum I _{CC} / Input	5.5			1.35		1.50	mA	V _{IN} = 3.4V Other Inputs = V _{CC} or GND
I _{OPD}	Output Leakage Current (Power Down State)	0.0			0.5		5.0	μA	V _{OUT} = 5.5V

DC Characteristics for 'VHCT Family Devices: See Section 2 for Waveforms

Symbol	Parameter	V _{CC} (V)	74VHCT		Units	Conditions	Fig. No.
			T _A = 25°C				
			Typ	Limit			
*V _{OLP}	Quiet Output Maximum Dynamic V _{OL}		0.4	0.8	V	C _L = 50 pF	2-11, 12
*V _{OLV}	Quiet Output Minimum Dynamic V _{OL}		-0.4	-0.8	V	C _L = 50 pF	2-11, 12
*V _{IHD}	Minimum High Level Dynamic Input Voltage			2.0	V	C _L = 50 pF	2-11, 12
*V _{ILD}	Maximum Low Level Dynamic Input Voltage			0.8	V	C _L = 50 pF	2-11, 12

*Parameter guaranteed by design.

AC Electrical Characteristics for 'VHC Family Devices: See Section 2 for Waveforms

Symbol	Parameter	V _{CC} (V)	74VHC			74VHC		Units	Conditions	Fig. No.
			T _A = 25°C			T _A = -40°C to +85°C				
			Min	Typ	Max	Min	Max			
t _{PHL} , t _{PLH}	Propagation Delay	3.3 ± 0.3	6.2	8.8	1.0	10.5	ns	C _L = 15 pF	2-5	
			8.7	12.3	1.0	14.0		C _L = 50 pF		
		5.0 ± 0.5	4.3	5.9	1.0	7.0	ns	C _L = 15 pF		
			5.8	7.9	1.0	9.0		C _L = 50 pF		
C _{IN}	Input Capacitance		4	10		10	pF	V _{CC} = Open		
C _{PD}	Power Dissipation Capacitance		18				pF	(Note 1)		

Note 1: C_{PD} is defined as the value of the internal equivalent capacitance which is calculated from the operating current consumption without load. Average operating current can be obtained by the equation: I_{CC (opr.)} = C_{PD} * V_{CC} * f_{IN} + I_{CC}/4 (per gate).

AC Electrical Characteristics for 'VHCT Family Devices: See Section 2 for Waveforms

Symbol	Parameter	V _{CC} (V)	74VHCT			74VHCT		Units	Conditions	Fig. No.
			T _A = 25°C			T _A = -40°C to +85°C				
			Min	Typ	Max	Min	Max			
t _{PLH} , t _{PHL}	Propagation Delay	5.0 ± 0.5	5.0	6.9	1.0	8.0	ns	C _L = 15 pF	2-5	
			5.5	7.9	1.0	9.0		C _L = 50 pF	2-5	
C _{IN}	Input Capacitance		4	10		10	pF	V _{CC} = Open		
C _{PD}	Power Dissipation Capacitance		18				pF	(Note 1)		

Note 1: C_{PD} is defined as the value of the internal equivalent capacitance, which is calculated from the operating current consumption without load. Average operating current can be obtained from the equation: I_{CC (opr.)} = C_{PD} * V_{CC} * f_{IN} + I_{CC}/4 (per gate)