

LR1117A

1A Adjustable/Fixed Low Dropout Linear Regulator

Features

- Low dropout voltage
- Load regulation: 0.05% typical
- Trimmed current limit
- On-chip thermal limiting
- Standard SOT-223, SOT89, TO-220 and TO-252 packages
- Three-terminal adjustable or fixed 1.8V, 2.5V, 3.3V, 5V

Applications

- Active SCSI terminators
- High efficiency linear regulators
- Post regulators for switching supplies
- Battery chargers
- 12V to 5V linear regulators
- Motherboard clock supplies

Description

The LR1117A and LR1117A-1.8, -2.5, -2.85, -3.3 and -5 are low dropout three-terminal regulators with 1A output current capability. These devices have been optimized for low voltage where transient response and minimum input voltage are critical. The 2.85V version is designed specifically to be used in Active Terminators for SCSI bus.

Current limit is trimmed to ensure specified output current and controlled short-circuit current. On-chip thermal limiting provides protection against any combination of overload and ambient temperatures that would create excessive junction temperatures.

Unlike PNP type regulators where up to 10% of the output current is wasted as quiescent current, the quiescent current of the LR1117A flows into the load, increasing efficiency.

The LR1117A series regulators are available in the industry-standard SOT-223, SOT89, TO-220, and TO-252 (DPAK) power packages.

Typical Applications

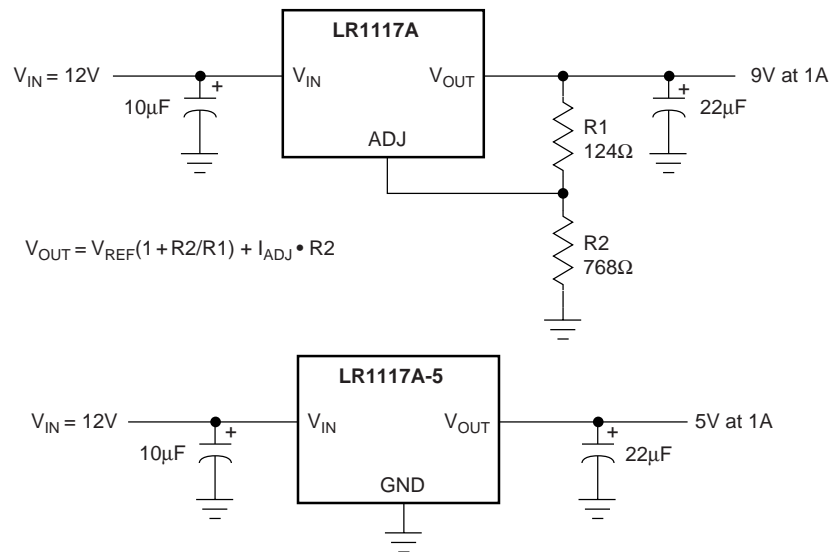

LR1117A

Pin Assignments

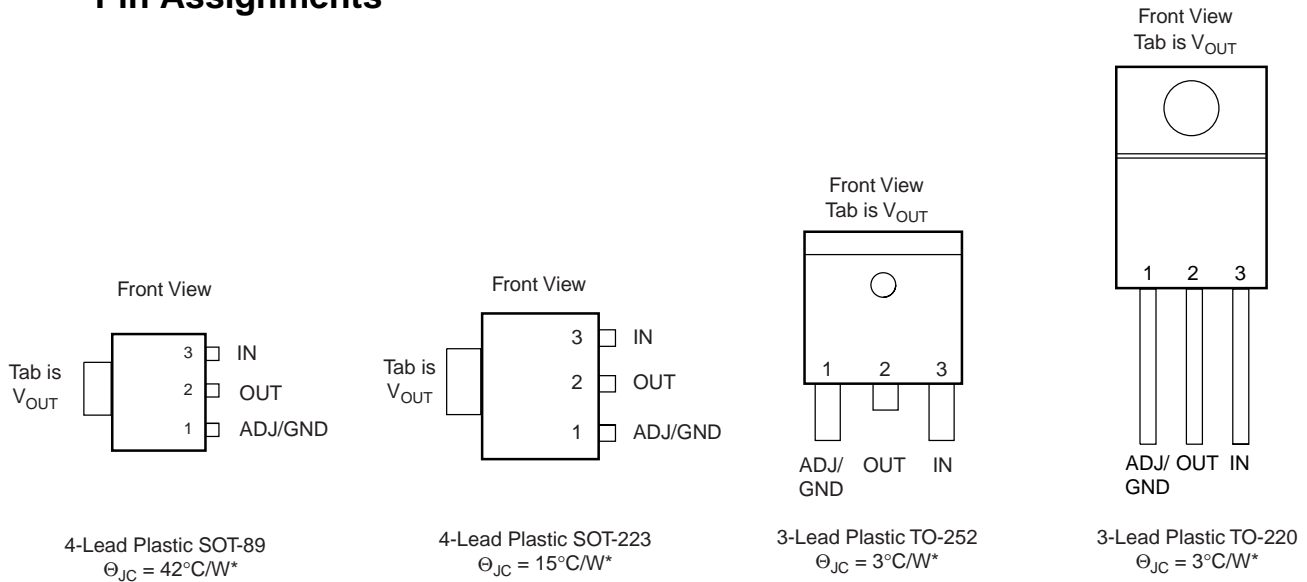

*With package soldered to 0.5 square inch copper area over backside ground plane or internal power plane, Θ_{JA} can vary from 30°C/W to more than 50°C/W . Other mounting techniques may provide better thermal resistance than 30°C/W .

Absolute Maximum Ratings

Parameter	Min.	Max.	Unit
V_{IN}		18	V
$(V_{IN} - V_{OUT}) * I_{OUT}$		See Figure 1	
Operating Junction Temperature Range	0	125	$^{\circ}\text{C}$
Storage Temperature Range	-65	150	$^{\circ}\text{C}$
Lead Temperature (Soldering, 10 sec.)		300	$^{\circ}\text{C}$

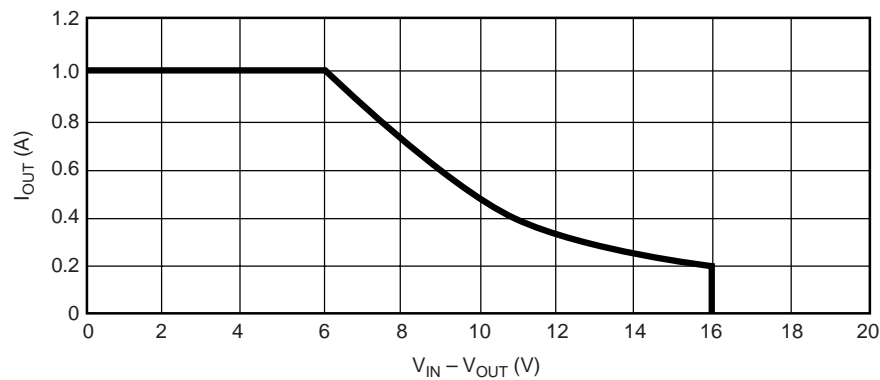

Figure 1. Absolute Maximum Safe Operating Area

LR1117A

Electrical Characteristics

Operating Conditions: $V_{IN} \leq 7V$, $T_J = 25^\circ C$ unless otherwise specified.

The • denotes specifications which apply over the specified operating temperature range.

Parameter	Conditions	Min.	Typ.	Max.	Units
Reference Voltage ³	$1.5V \leq (V_{IN} - V_{OUT}) \leq 7V$, $10mA \leq I_{OUT} \leq 1A$ •	1.225 (-2%)	1.250	1.275 (+2%)	V
Output Voltage ⁴	$10mA \leq I_{OUT} \leq 1A$ LR1117A-1.8, $3.3V \leq V_{IN} \leq 8.8V$ • LR1117A-2.5, $4V \leq V_{IN} \leq 9.5V$ • LR1117A-3.3, $4.8V \leq V_{IN} \leq 10.3V$ • LR1117A-5, $6.5V \leq V_{IN} \leq 12V$ •	1.764 2.450 3.234 4.900	1.8 2.5 3.3 5.0	1.836 2.550 3.366 5.100	V V V V
Line Regulation ^{1,2}	$(V_{OUT} + 1.5V) \leq V_{IN} \leq 12V$, $I_{OUT} = 10mA$ •		0.005	0.2	%
Load Regulation ^{1,2}	$(V_{IN} - V_{OUT}) = 2V$, $10mA \leq I_{OUT} \leq 1A$ •		0.05	0.5	%
Dropout Voltage	$\Delta V_{REF} = 1\%$, $I_{OUT} = 1A$ •		1.100	1.200	V
Current Limit	$(V_{IN} - V_{OUT}) = 2V$ •	1.1	1.5		A
Adjust Pin Current ³	•		35	120	μA
Adjust Pin Current Change ^{3,4}	$1.5V \leq (V_{IN} - V_{OUT}) \leq 7V$, $10mA \leq I_{OUT} \leq 1A$ •		0.2	5	μA
Minimum Load Current	$1.5V \leq (V_{IN} - V_{OUT}) \leq 15V$ •	10			mA
Quiescent Current	$V_{IN} = V_{OUT} + 1.25V$ •		4	13	mA
Ripple Rejection	$f = 120Hz$, $C_{OUT} = 22\mu F$ Tantalum, $(V_{IN} - V_{OUT}) = 3V$, $I_{OUT} = 1A$	60	72		dB
Thermal Regulation	$T_A = 25^\circ C$, 30ms pulse		0.004	0.02	%/W
Temperature Stability	•		0.5		%
Long-Term Stability	$T_A = 125^\circ C$, 1000hrs.		0.03	1.0	%
RMS Output Noise (% of V_{OUT})	$T_A = 25^\circ C$, $10Hz \leq f \leq 10kHz$		0.003		%
Thermal Resistance, Junction to Case	SOT-223 TO-252, TO-220 SOT89		15 3 42		$^\circ C/W$ $^\circ C/W$ $^\circ C/W$
Thermal Shutdown	Junction Temperature		155		$^\circ C$
Thermal Shutdown Hysteresis			10		$^\circ C$

Notes:

- See thermal regulation specifications for changes in output voltage due to heating effects. Load and line regulation are measured at a constant junction temperature by low duty cycle pulse testing.
- Line and load regulation are guaranteed up to the maximum power dissipation (18W). Power dissipation is determined by input/output differential and the output current. Guaranteed maximum output power will not be available over the full input/output voltage range.
- LR1117A only.
- Output current must be limited to meet the absolute maximum ratings of the part.

LR1117A

Typical Performance Characteristics

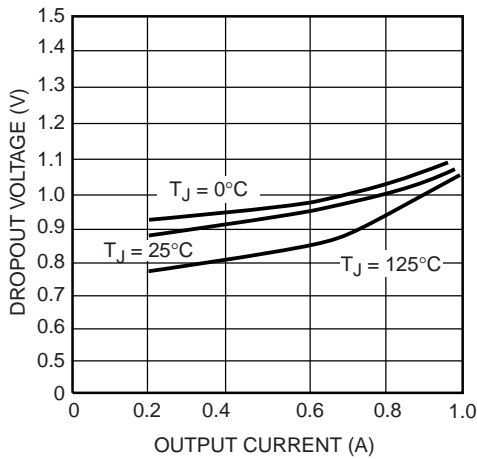

Figure 2. Dropout Voltage vs. Output Current

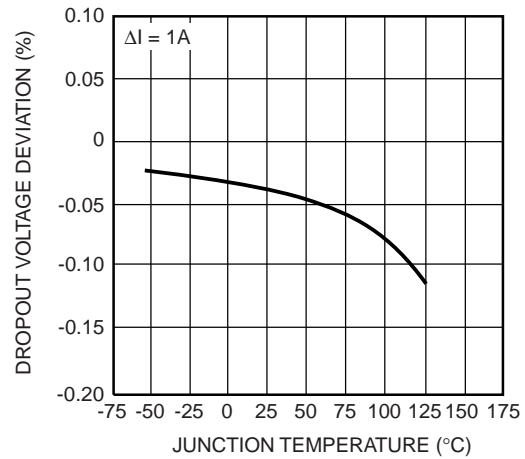

Figure 3. Load Regulation vs. Temperature

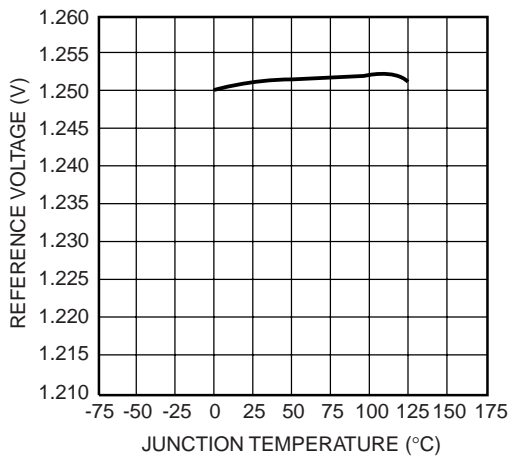

Figure 4. Reference Voltage vs. Temperature

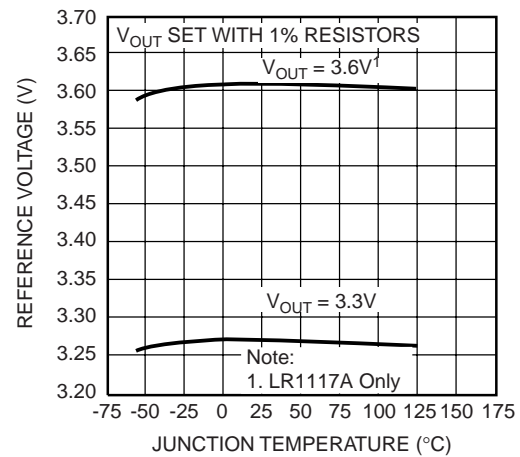

Figure 5. Output Voltage vs. Temperature

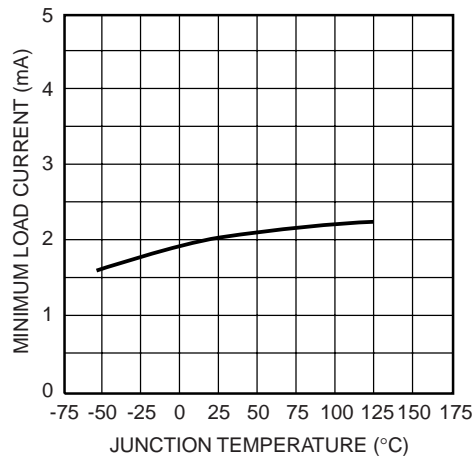

Figure 6. Minimum Load Current vs. Temperature

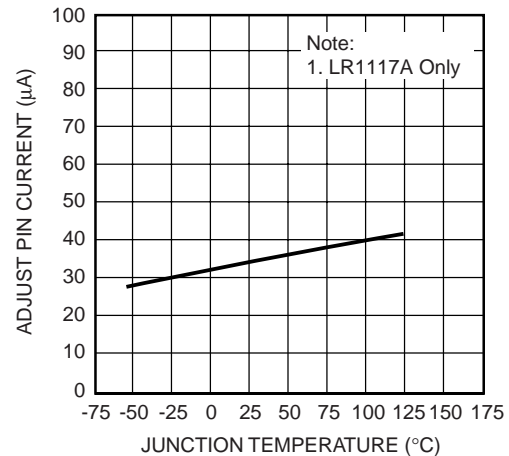

Figure 7. Adjust Pin Current vs. Temperature

LR1117A

Typical Performance Characteristics (continued)

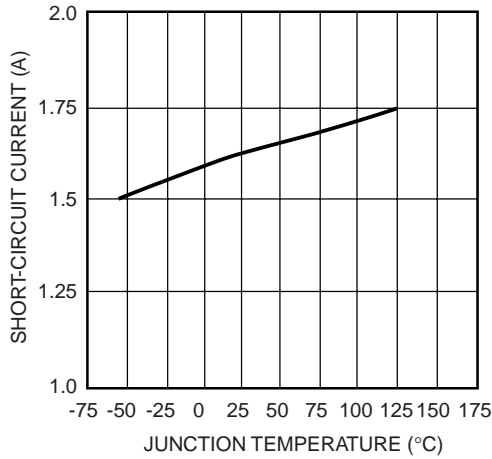

Figure 8. Short-Circuit Current vs. Temperature

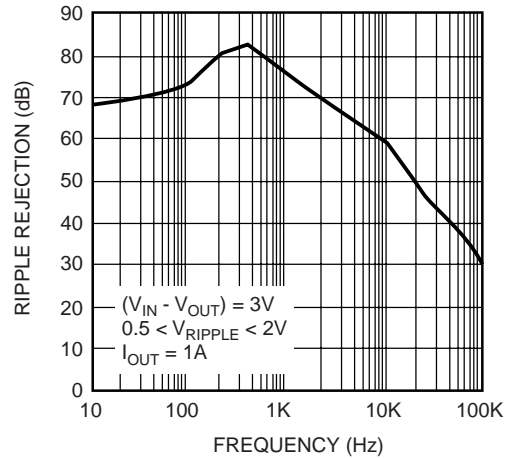

Figure 9. Ripple Rejection vs. Frequency

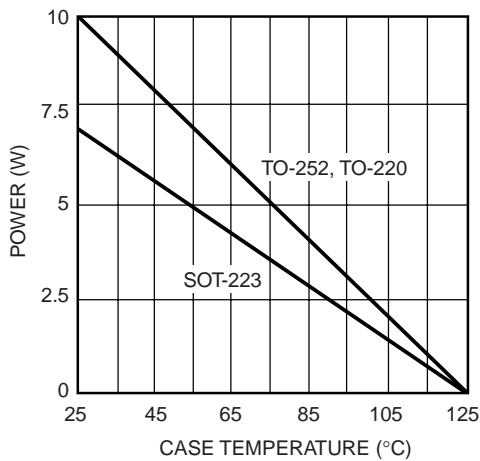

Figure 10. Maximum Power Dissipation

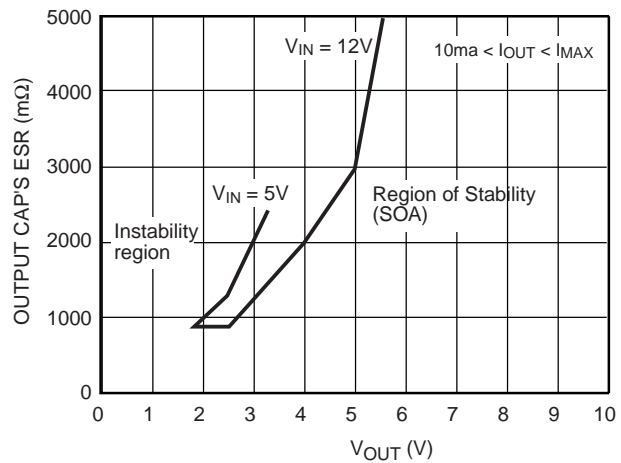

Figure 11. Stability Region (SOA) vs. ESR of the C_{OUT}

LR1117A

Mechanical Dimensions

4-Lead SOT-223 Package

Symbol	Inches		Millimeters		Notes
	Min.	Max.	Min.	Max.	
A	—	.071	—	1.80	
A1	—	.181	—	4.80	
B	.025	.033	.640	.840	
c	—	.090	—	2.29	
D	.248	.264	6.30	6.71	
E	.130	.148	3.30	3.71	
e	.115	.124	2.95	3.15	
F	.033	.041	.840	1.04	
H	.264	.287	6.71	7.29	
I	.012	—	.310	—	
J	—	10°	—	10°	
K	10°	16°	10°	16°	
L	.0008	.0040	.0203	.1018	
M	10°	16°	10°	16°	
N	.010	.014	.250	.360	

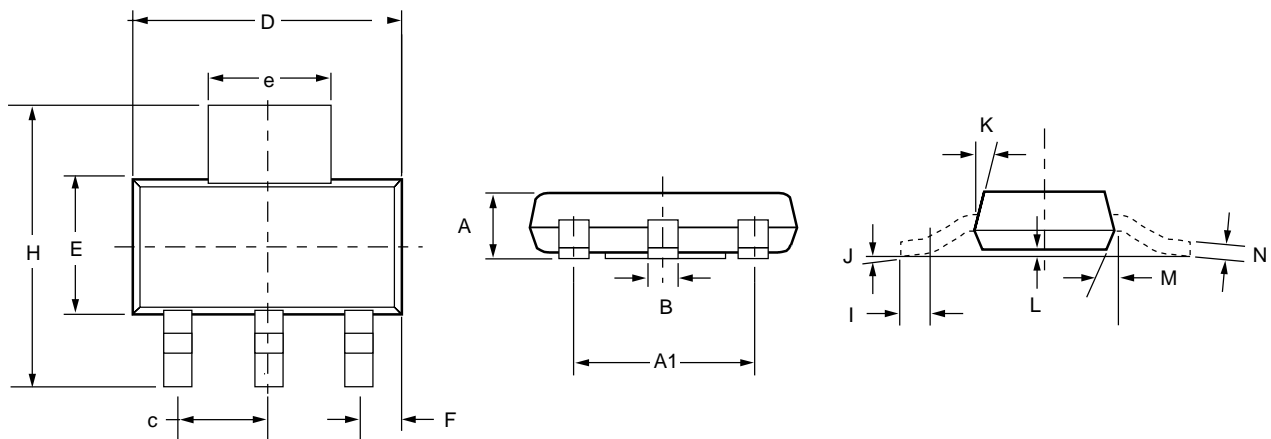

LR1117A

Mechanical Dimensions (continued)

3-Lead TO-220 Package

Symbol	Inches		Millimeters		Notes
	Min.	Max.	Min.	Max.	
A	.140	.190	3.56	4.83	
b	.015	.040	.38	1.02	
b1	.045	.070	1.14	1.78	
c1	.014	.022	.36	.56	
øP	.139	.161	3.53	4.09	
D	.560	.650	14.22	16.51	
E	.380	.420	9.65	10.67	
e	.090	.110	2.29	2.79	
e1	.190	.210	4.83	5.33	
e3	.045	—	1.14	—	
F	.020	.055	.51	1.40	
H1	.230	.270	5.94	6.87	
J1	.080	.115	2.04	2.92	
L	.500	.580	12.70	14.73	
L1	.250 BSC		6.35 BSC		
Q	.100	.135	2.54	3.43	
α	3°	7°	3°	7°	

Notes:

1. Dimension c1 apply for lead finish.

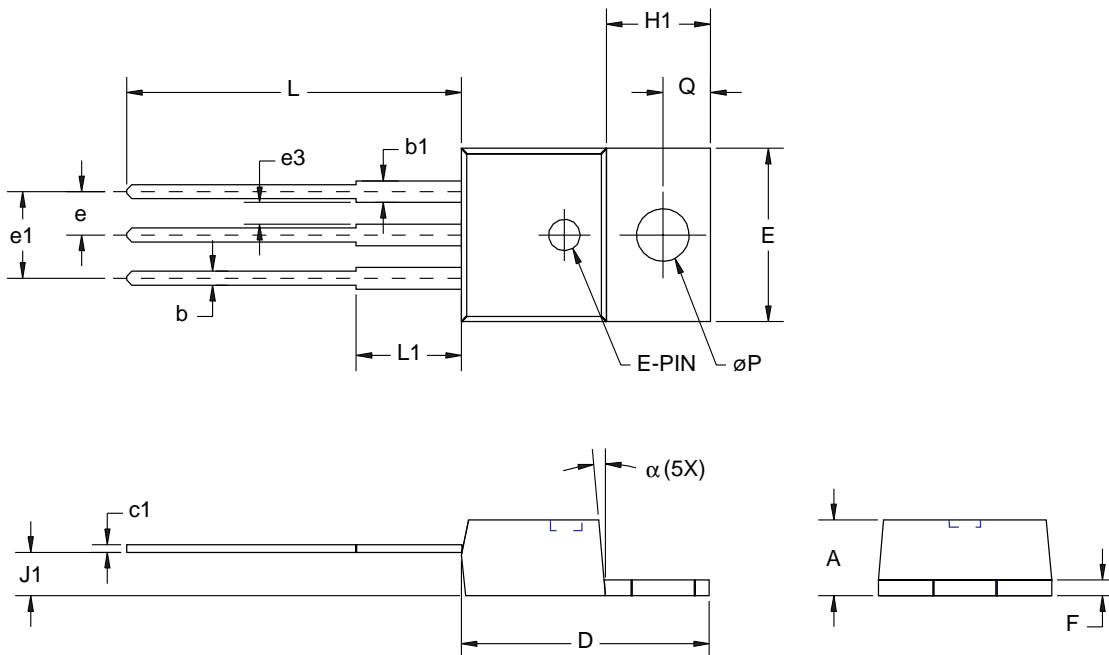

LR1117A

Mechanical Dimensions (continued)

3-Lead TO-252 Package

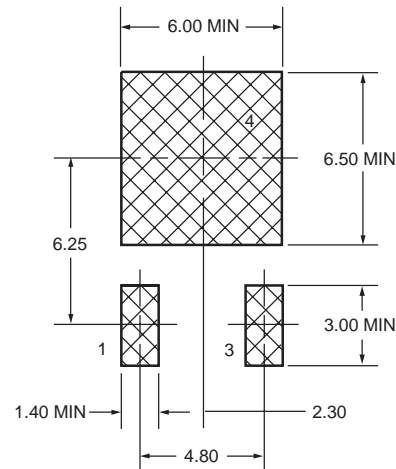
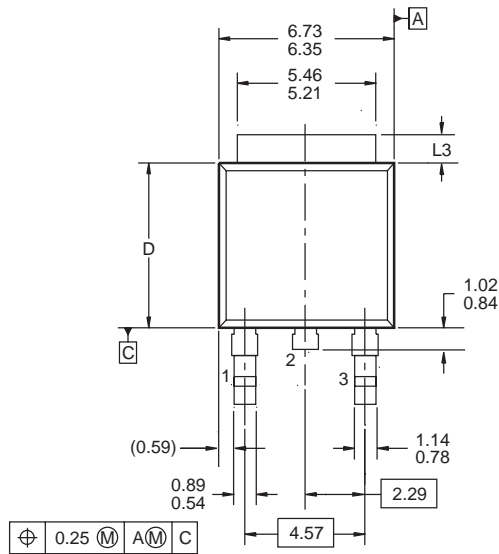

LAND PATTERN RECOMMENDATION

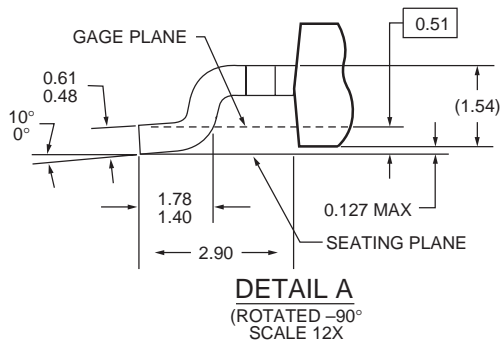
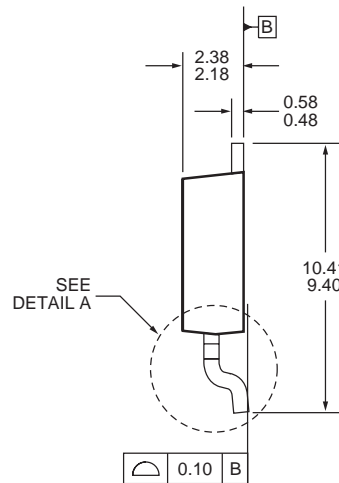
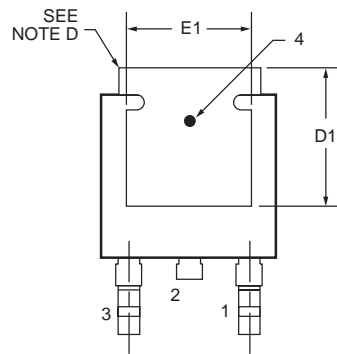

NOTES: UNLESS OTHERWISE SPECIFIED

- A) ALL DIMENSIONS ARE IN MILLIMETERS.
- B) THIS PACKAGE CONFORMS TO JEDEC, TO-252, ISSUE C. VARIATION AA & AB, DATED NOV. 1999.
- C) DIMENSIONING AND TOLERANCING PER ASME Y14.5-1994.
- D) HEAT SINK TOP EDGE COULD BE IN CHAMFERED CORNERS OR EDGE PROTRUSION.
- E) DIMENSIONS L3, D, E1 & D1 TABLE:

	OPTION AA	OPTION AB
L3	0.89 - 1.27	1.52 - 2.03
D	5.97 - 6.22	5.33 - 5.59
E1	4.32 MIN	3.81 MIN
D1	5.21 MIN	4.57 MIN

LR1117A

SOT-89

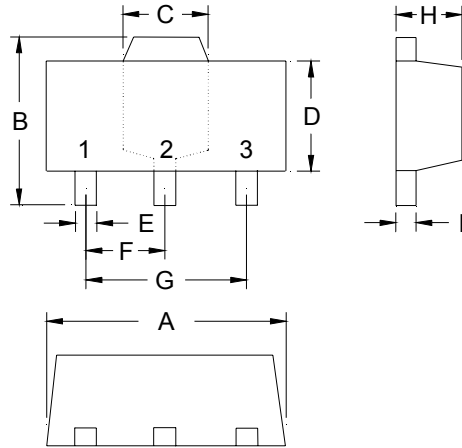

DIM	Min.	Max.
A	4.40	4.60
B	4.05	4.25
C	1.50	1.70
D	2.40	2.60
E	0.36	0.51
F	*1.50	-
G	*3.00	-
H	1.40	1.60
I	0.35	0.41

*: Typical, Unit: mm

LR1117A

Ordering Information

Product Number	Package
LR1117ADX	TO-252 in tape and reel
LR1117ASX	SOT-223 in tape and reel
LR1117AEX	SOT-89 in tape and reel
LR1117AD18X	TO-252 in tape and reel
LR1117AS18X	SOT-223 in tape and reel
LR1117AE18X	SOT-89 in tape and reel
LR1117AD25X	TO-252 in tape and reel
LR1117AS25X	SOT-223 in tape and reel
LR1117AE25X	SOT-89 in tape and reel
LR1117AD285	TO-252
LR1117AS285	SOT-223 in tape and reel
LR1117AE285	SOT-89 in tape and reel
LR1117AD33X	TO-252 in tape and reel
LR1117AS33X	SOT-223 in tape and reel
LR1117AE33X	SOT-89 in tape and reel
LR1117AD5X	TO-252 in tape and reel
LR1117AS5X	SOT-223 in tape and reel
LR1117AE5X	SOT-89 in tape and reel
LR1117AT	TO-220
LR1117AT18	TO-220
LR1117AT25	TO-220
LR1117AT33	TO-220