

PRELIMINARY

Notice: This is not a final specification.
Some parametric limits are subject to change.

MITSUBISHI LSI's M5M416160CJ, TP-5,-6,-7, -5S,-6S,-7S

FAST PAGE MODE 1677216-BIT (1048576-WORD BY 16-BIT) DYNAMIC RAM

DESCRIPTION

This is a family of 1048576-word by 16-bit dynamic RAMS, fabricated with the high performance CMOS process, and is ideal for large-capacity memory systems where high speed, low power dissipation, and low costs are essential.

The use of double-layer metal process combined with twin-well CMOS technology and a single-transistor dynamic storage stacked capacitor cell provide high circuit density at reduced costs. Multiplexed address inputs permit both a reduction in pins and an increase in system densities.

FEATURES

Type name	RAS access time (max.ns)	CAS access time (max.ns)	Address access time (max.ns)	OE access time (max.ns)	Cycle time (min.ms)	Power dissipation (tp,mW)
M5M416160CXX-5,-5S	50	13	25	13	90	540
M5M416160CXX-6,-6S	60	15	30	15	110	430
M5M416160CXX-7,-7S	70	20	35	20	130	385

XX=J,TP

- Standard 42 pin SOJ, 50 pin TSOP
- Single 5.0V $\pm 10\%$ supply
- Low stand-by power dissipation
5.5mW (Max) ----- CMOS Input level
- Low operating power dissipation
M5M416160Cxx-5,-5S ----- 660.0mW (Max)
M5M416160Cxx-6,-6S ----- 525.0mW (Max)
M5M416160Cxx-7,-7S ----- 470.0mW (Max)
- Fast-page mode, Read-modify-write, RAS-only refresh
CAS before RAS refresh, Hidden refresh capabilities
- Early-write mode and OE to control output buffer impedance
All inputs, output TTL compatible and low capacitance
- 4096 refresh cycles every 64ms (A₀ ~ A₁₁)
* : Applicable to self refresh version (M5M416160CJ, TP-5S,-6S,-7S : option) only

APPLICATION

Main memory unit for computers, Microcomputer memory,
Refresh memory for CRT

PIN DESCRIPTION

Pin name	Function
A ₀ ~A ₁₁	Address inputs
DQ ₁ ~DQ ₁₆	Data inputs / outputs
RAS	Row address strobe input
UCAS	Upper byte control column address strobe input
LCAS	Lower byte control column address strobe input
W	Write control input
OE	Output enable input
Vcc	Power supply (+5.0V)
Vss	Ground (0V)

PIN CONFIGURATION (TOP VIEW)

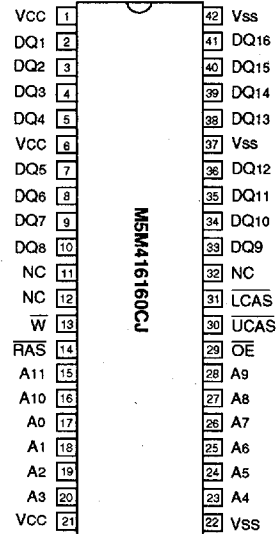

Outline 42P0N-A (400mil SOJ)

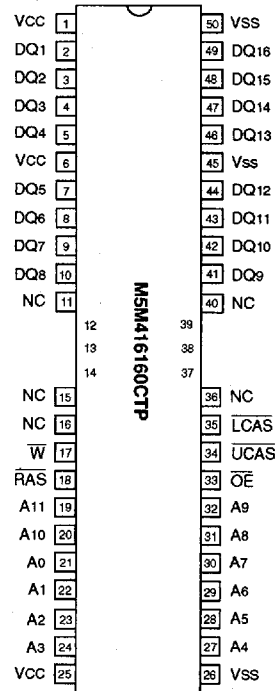

Outline 50P3G-F (400mil TSOP Normal Bend)

NC : NO CONNECTION

6249825 0028802 TTT

M5M416160CJ, TP-5, -6, -7, -5S, -6S, -7S

PRELIMINARY

Notice: This is not a final specification.
Some parameter limits are subject to change.

FAST PAGE MODE 1677216-BIT (1048576-WORD BY 16-BIT) DYNAMIC RAM

FUNCTION

The M5M416160CJ, TP provide, in addition to normal read, write, and read-modify-write operations, a number of other functions, e.g.,

fast page mode, $\overline{\text{RAS}}$ -only refresh, and delayed-write. The input conditions for each are shown in Table 1.

Table 1 Input conditions for each mode

Operation	Inputs					Input/Output	
	RAS	LCAS	UCAS	W	$\overline{\text{OE}}$	DQ1-DQ8	DQ9-DQ16
Lower byte read	ACT	ACT	NAC	NAC	ACT	DOUT	OPN
Upper byte read	ACT	NAC	ACT	NAC	ACT	OPN	DOUT
Word read	ACT	ACT	ACT	NAC	ACT	DOUT	DOUT
Lower byte write	ACT	ACT	NAC	ACT	NAC	DIN	DNC
Upper byte write	ACT	NAC	ACT	ACT	NAC	DNC	DIN
Word write	ACT	ACT	ACT	ACT	NAC	DIN	DIN
$\overline{\text{RAS}}$ -only refresh	ACT	NAC	NAC	DNC	DNC	OPN	OPN
Hidden refresh	ACT	ACT	ACT	NAC	ACT	DOUT	DOUT
CAS before $\overline{\text{RAS}}$ refresh	ACT	ACT	ACT	DNC	DNC	OPN	OPN
Stand-by	NAC	DNC	DNC	DNC	DNC	OPN	OPN

Note: ACT: active, NAC: nonactive, DNC: don't care, VLD: valid, IVD: invalid, APD: applied, OPN: open

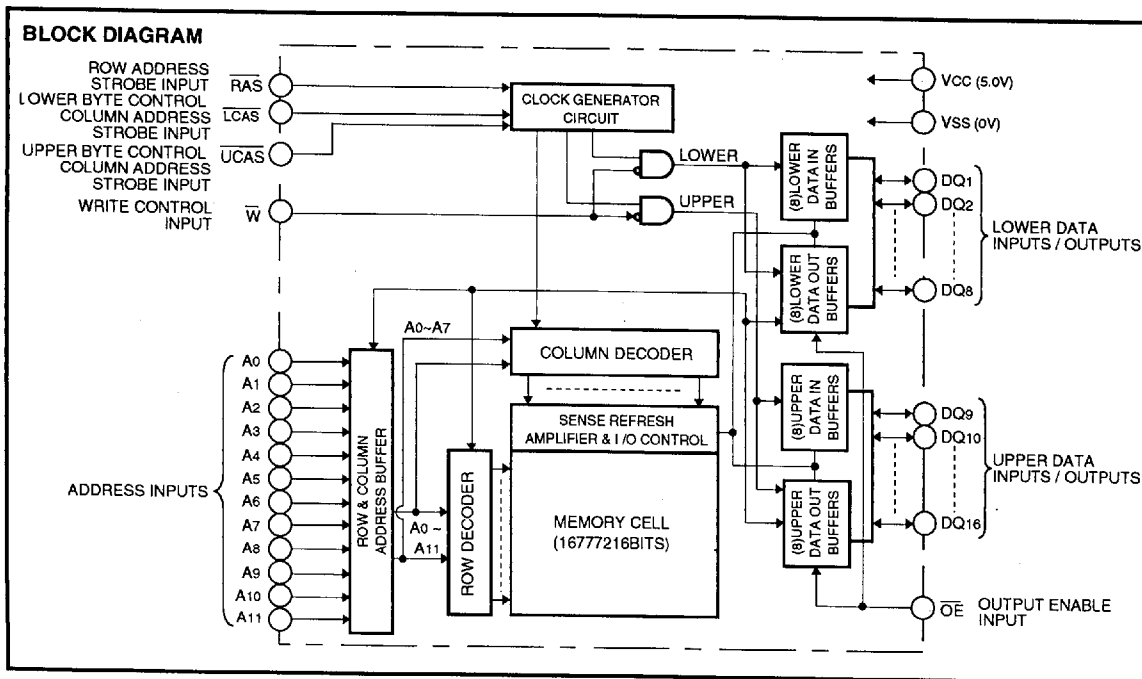

6249825 0028803 936



M5M416160CJ, TP-5, -6, -7, -5S, -6S, -7S

PRELIMINARY
 Note: This is not a final specification.
 Some parametric limits are subject to change.

FAST PAGE MODE 1677216-BIT (1048576-WORD BY 16-BIT) DYNAMIC RAM

ABSOLUTE MAXIMUM RATINGS

Symbol	Parameter	Conditions	Ratings	Unit
Vcc	Supply voltage	With respect to Vss	-1~7	V
Vi	Input voltage		-1~7	V
Vo	Output voltage		-1~7	V
Io	Output current		50	mA
Pd	Power dissipation	Ta=25 °C	1000	mW
Topr	Operating temperature		0 ~ 70	°C
Tstg	Storage temperature		-65 ~ 150	°C

RECOMMENDED OPERATING CONDITIONS (Ta=0~70°C, unless otherwise noted) (Note 1)

Symbol	Parameter	Limits			Unit
		Min	Nom	Max	
Vcc	Supply voltage	4.5	5.0	5.5	V
Vss	Supply voltage	0	0	0	V
VIH	High-level input voltage, all inputs	2.4		6.0	V
VIL	Low-level input voltage, all inputs	-1		0.8	V

Note 1: All voltage values are with respect to Vss.

ELECTRICAL CHARACTERISTICS (Ta=0~70°C, Vcc=5.0V±10%, Vss=0V, unless otherwise noted) (Note 2)

Symbol	Parameter	Test conditions	Limits			Unit	
			Min	Typ	Max		
VOH	High-level output voltage	IOH=-5mA	2.4		Vcc	V	
VOL	Low-level output voltage	IOl=4.2mA	0		0.4	V	
IOZ	Off-state output current	Q floating 0V ≤ VOUT ≤ 5.5V	-10		10	µA	
II	Input current	0V ≤ VIN ≤ 6V, Other inputs pins=0V	-10		10	µA	
ICC1(AV)	Average supply current from Vcc operating (Note 3,4,5)	M5M416160C-5,-5S	RAS, CAS cycling trc=twc=min. output open			120	mA
		M5M416160C-6,-6S				95	
		M5M416160C-7,-7S				85	
ICC2	Supply current from Vcc, stand-by (Note 6)	RAS=CAS=VIH, output open				2	mA
		RAS=CAS ≥ Vcc-0.2V output open				1 0.3*	
ICC3(AV)	Average supply current from Vcc refreshing (Note 3,5)	M5M416160C-5,-5S	RAS cycling, CAS=VIH trc=min. output open			120	mA
		M5M416160C-6,-6S				95	
		M5M416160C-7,-7S				85	
ICC4(AV)	Average supply current from Vcc Fast-page-mode (Note 3,4,5)	M5M416160C-5,-5S	RAS=VIL, CAS cycling tpc=min. output open			80	mA
		M5M416160C-6,-6S				70	
		M5M416160C-7,-7S				65	
ICC6(AV)	Average supply current from Vcc CAS before RAS refresh mode (Note 3)	M5M416160C-5,-5S	CAS before RAS refresh cycling trc=min. output open			120	mA
		M5M416160C-6,-6S				95	
		M5M416160C-7,-7S				85	
ICC8(AV) *	Average supply current from Vcc Extended-refresh cycle (Note 6)	M5M416160C (S)	Stand-by: RAS ≥ Vcc-0.2V CAS ≥ Vcc-0.2V or CAS ≤ 0.2V CAS before RAS refresh: RAS cycling CAS ≤ 0.2V or CAS before RAS refresh cycling W ≤ 0.2V or ≥ Vcc-0.2V OE ≤ 0.2V or ≥ Vcc-0.2V A0~A11 ≤ 0.2V or ≥ Vcc-0.2V DQ=open, trc=125 µs, tRAS=tRASmin~1 µs			600	µA
ICC9(AV) *	Average supply current from Vcc Self-refresh cycle	M5M416160C (S)	RAS=CAS ≤ 0.2V			400	µA

Note 2: Current flowing into an IC is positive, out is negative.
 3: ICC1 (AV), ICC3 (AV) and ICC4 (AV) are dependent on cycle rate. Maximum current is measured at the fastest cycle rate.
 4: ICC1 (AV) and ICC4 (AV) are dependent on output loading. Specified values are obtained with the output open.
 5: Column Address can be changed once or less while RAS=VIL and LCAS/UCAS=VIH.

6249825 0028804 872



M5M416160CJ,TP-5,-6,-7,-5S,-6S,-7S

PRELIMINARY

Notice: This is not a final specification
Some parametric limits are subject to change.

FAST PAGE MODE 1677216-BIT (1048576-WORD BY 16-BIT) DYNAMIC RAM

CAPACITANCE (Ta=0~70°C, Vcc=5.0V±10%, Vss=0V, unless otherwise noted)

Symbol	Parameter	Test conditions	Limits			Unit
			Min	Typ	Max	
CI(A)	Input capacitance, address inputs	Vi=Vss f=1MHz Vi=25mVrms			5	pF
CI(OE)	Input capacitance, OE input				7	pF
CI(W)	Input capacitance, write control input				7	pF
CI(RAS)	Input capacitance, RAS input				7	pF
CI(CAS)	Input capacitance, CAS input				7	pF
CI/O	Input/Output capacitance, data ports				7	pF

SWITCHING CHARACTERISTICS (Ta=0~70°C, Vcc=5.0V±10%, Vss=0V, unless otherwise noted, see notes 6,13,14)

Symbol	Parameter	Limits						Unit
		M5M416160C-5,-5S		M5M416160C-6,-6S		M5M416160C-7,-7S		
		Min	Max	Min	Max	Min	Max	
tCAC	Access time from CAS (Note 7,8)		13		15		20	ns
tRAC	Access time from RAS (Note 7,9)		50		60		70	ns
tAA	Column address access time (Note 7,10)		25		30		35	ns
tCPA	Access time from CAS precharge (Note 7,11)		30		35		40	ns
tOEA	Access time from OE (Note 7)		13		15		20	ns
tCLZ	Output low impedance time from CAS low (Note 7)	5		5		5		ns
tOFF	Output disable time after CAS high (Note 12)	0	13	0	15	0	15	ns
tOEZ	Output disable time after OE high (Note 12)	0	13	0	15	0	15	ns

Note 6: An initial pause of 500 μs is required after power-up followed by a minimum of eight initialization cycles (any combination of cycles containing a RAS clock such as RAS-Only refresh).

Note the RAS may be cycled during the initial pause. And any 8 RAS or RAS/CAS cycles are required after prolonged periods (greater than 64ms) of RAS inactivity before proper device operation is achieved.

7: Measured with a load circuit equivalent to VOH=2.4V(IoH=-5mA) / VOL=0.4V(IoL=4.2mA) load 100pF.

The reference levels for measuring of output signal are 2.4V(VOH) and 0.4V(VOL).

8: Assumes that tRCD ≥ tRCD(max) and tASC ≥ tASC(max).

9: Assumes that tRCD ≤ tRCD(max) and tRAD ≤ tRAD(max). If tRCD or tRAD is greater than the maximum recommended value shown in this table, tRAC will increase by amount that tRCD exceeds the value shown.

10: Assumes that tRAD ≥ tRAD(max) and tASC ≤ tASC(max).

11: Assumes that tCP ≤ tCP(max) and tASC ≥ tASC(max).

12: tOFF(max) and tOEZ(max) defines the time at which the output achieves the high impedance state (IOU ≤ ±10 μA) and is not reference to VOH(min) or VOL(max).

6249825 0028805 709



PRELIMINARY

Notice: This is not a final specification.
Some parametric limits are subject to change.

M5M416160CJ,TP-5,-6,-7,-5S,-6S,-7S

FAST PAGE MODE 1677216-BIT (1048576-WORD BY 16-BIT) DYNAMIC RAM

TIMING REQUIREMENTS (For Read, Write, Read-Modify-Write, Refresh and Fast-Page Mode Cycles)

(Ta=0~70°C, Vcc=5.0V±10%, Vss=0V, unless otherwise noted, see notes 13,14)

Symbol	Parameter	Limits						Unit
		M5M416160C-5,-5S		M5M416160C-6,-6S		M5M416160C-7,-7S		
		Min	Max	Min	Max	Min	Max	
tREF	Refresh cycle time		64		64		64	ms
tREF*	Refresh cycle time		128		128		128	ms
tRP	RAS high pulse width	30		40		50		ns
tRCD	Delay time, RAS low to CAS low (Note 15)	18	37	20	45	20	50	ns
tCRP	Delay time, CAS high to RAS low	10		10		10		ns
tRPC	Delay time, RAS high to CAS low	0		0		0		ns
tCPN	CAS high pulse width	10		10		10		ns
tRAD	Column address delay time from RAS low (Note 16)	13	25	15	30	15	35	ns
tASR	Row address setup time before RAS low	0		0		0		ns
tASC	Column address setup time before CAS low (Note 17)	0	10	0	10	0	10	ns
tRAH	Row address hold time after RAS low	8		10		10		ns
tCAH	Column address hold time after CAS low	13		15		15		ns
tDZC	Delay time, data to CAS low (Note 18)	0		0		0		ns
tDZO	Delay time, data to OE low (Note 18)	0		0		0		ns
tCDD	Delay time, CAS high to data (Note 19)	13		15		15		ns
tODD	Delay time, OE high to data (Note 19)	13		15		15		ns
tT	Transition time (Note 20)	1	50	1	50	1	50	ns

Note 13: The timing requirements are assumed $t_T = 5ns$.

14: VIH(min) and VIL(max) are reference levels for measuring timing of input signals.

15: tRCD(max) is specified as a reference point only. If tRCD is less than tRCD(max), access time is tRAC. If tRCD is greater than tRCD(max), access time is controlled exclusively by tCAC or tAA. tRCD(min) is specified as $tRCD(min) = tRAH(min) + 2t_T + tASC(min)$.

16: tRAD(max) is specified as a reference point only. If $tRAD \geq tRAD(max)$ and $tASC \leq tASC(max)$, access time is controlled exclusively by tAA.

17: tASC(max) is specified as a reference point only. If $tRCD \geq tRCD(max)$ and $tASC \geq tASC(max)$, access time is controlled exclusively by tCAC.

18: Either tDZC or tDZO must be satisfied.

19: Either tCDD or tODD must be satisfied.

20: tT is measured between VIH(min) and VIL(max).

Read and Refresh Cycles

Symbol	Parameter	Limits						Unit
		M5M416160C-5,-5S		M5M416160C-6,-6S		M5M416160C-7,-7S		
		Min	Max	Min	Max	Min	Max	
tRC	Read cycle time	90		110		130		ns
tRAS	RAS low pulse width	50	10000	60	10000	70	10000	ns
tCAS	CAS low pulse width	13	10000	15	10000	20	10000	ns
tCSH	CAS hold time after RAS low	50		60		70		ns
tRSH	RAS hold time after CAS low	13		15		20		ns
tRCS	Read setup time before CAS low	0		0		0		ns
tRCH	Read hold time after CAS high (Note 21)	0		0		0		ns
tRRH	Read hold time after RAS high (Note 21)	10		10		10		ns
tRAL	Column address to RAS hold time	25		30		35		ns
tOCH	CAS hold time after OE low	13		15		20		ns
tORH	RAS hold time after OE low	13		15		20		ns

Note 21: Either tRCH or tRRH must be satisfied for a read cycle.

6249825 0028806 645



PRELIMINARY

Notice: This is not a final specification.
Some parametric limits are subject to change.

FAST PAGE MODE 1677216-BIT (1048576-WORD BY 16-BIT) DYNAMIC RAM

Write Cycle (Early Write and Delayed Write)

Symbol	Parameter	Limits						Unit
		M5M416160C-5,-5S		M5M416160C-6,-6S		M5M416160C-7,-7S		
		Min	Max	Min	Max	Min	Max	
tWC	Write cycle time	90		110		130		ns
tRAS	RAS low pulse width	50	10000	60	10000	70	10000	ns
tCAS	CAS low pulse width	13	10000	15	10000	20	10000	ns
tCSH	CAS hold time after RAS low	50		60		70		ns
tRSH	RAS hold time after CAS low	13		15		20		ns
twCS	Write setup time before CAS low (Note 23)	0		0		0		ns
twCH	Write hold time after CAS low	8		10		15		ns
tcWL	CAS hold time after W low	13		15		20		ns
tRWL	RAS hold time after W low	13		15		20		ns
tWP	Write pulse width	8		10		15		ns
tDS	Data setup time before CAS low or W low	0		0		0		ns
tDH	Data hold time after CAS low or W low	10		15		15		ns
tOEH	OE hold time after W low	13		15		20		ns

Read-Write and Read-Modify-Write Cycles

Symbol	Parameter	Limits						Unit
		M5M416160C-5,-5S		M5M416160C-6,-6S		M5M416160C-7,-7S		
		Min	Max	Min	Max	Min	Max	
tRWC	Read write/read modify write cycle time (Note 22)	131		155		180		ns
tRAS	RAS low pulse width	91	10000	105	10000	120	10000	ns
tCAS	CAS low pulse width	54	10000	60	10000	70	10000	ns
tCSH	CAS hold time after RAS low	91		105		120		ns
tRSH	RAS hold time after CAS low	54		60		70		ns
tRCS	Read setup time before CAS low	0		0		0		ns
tcWD	Delay time, CAS low to W low (Note 23)	36		40		45		ns
tRWD	Delay time, RAS low to W low (Note 23)	73		85		95		ns
tAWD	Delay time, address to W low (Note 23)	48		55		60		ns
tcWL	CAS hold time after W low	13		15		20		ns
tRWL	RAS hold time after W low	13		15		20		ns
tWP	Write pulse width	8		10		10		ns
tDS	Data setup time before W low	0		0		0		ns
tDH	Data hold time after W low	10		10		15		ns
tOEH	OE hold time after W low	13		15		15		ns

Note 22: tRWC is specified as tRWC(min)=tRAC(max)+tODD(min)+tRWL(min)+tRP(min)+5tT.

Note 23: twCS, tcWD, tRWD and tAWD are specified as reference points only. If twCS ≥ twCS(min) the cycle is an early write cycle and the DQ pins will remain high impedance throughout the entire cycle. If tcWD ≥ tcWD(min), tRWD ≥ tRWD(min), tAWD ≥ tAWD(min) and tcpWD ≥ tcpWD(min) (for fast page mode cycle only), the cycle is a read-modify-write cycle and the DQ will contain the data read from the selected address. If neither of the above condition (delayed write) of the DQ (at access time and until CAS or OE goes back to VIH) is indeterminate.

Fast-Page Mode Cycle (Read, Early Write, Read-Write, Read-Modify-Write Cycle) (Note 24)

Symbol	Parameter	Limits						Unit
		M5M416160C-5,-5S		M5M416160C-6,-6S		M5M416160C-7,-7S		
		Min	Max	Min	Max	Min	Max	
tPC	Fast page mode read/write cycle time	35		40		45		ns
tPRWC	Fast page mode read write/read modify write cycle time	76		85		95		ns
tRAS	RAS low pulse width for read write cycle (Note 25)	85	125000	100	125000	115	125000	ns
tCP	CAS high pulse width (Note 26)	8	12	10	15	10	15	ns
tCPRH	RAS hold time after CAS precharge	30		35		40		ns
tcpWD	Delay time, CAS precharge to W low (Note 23)	53		60		65		ns

Note 24: All previously specified timing requirements and switching characteristics are applicable to their respective fast page mode cycle.

25: tRAS(min) is specified as two cycles of CAS input are performed.

26: tCP(max) is specified as a reference point only.

6249825 0028807 581



PRELIMINARY
 Notice: This is not a final specification.
 Some parametric limits are subject to change.

FAST PAGE MODE 1677216-BIT (1048576-WORD BY 16-BIT) DYNAMIC RAM

CAS before RAS Refresh Cycle (Note 27)

Symbol	Parameter	Limits						Unit
		M5M416160C-5,-5S		M5M416160C-6,-6S		M5M416160C-7,-7S		
		Min	Max	Min	Max	Min	Max	
tCSR	CAS setup time before RAS low	10		10		10		ns
tCHR	CAS hold time after RAS low	10		10		15		ns

Note 27: Eight or more CAS before RAS cycles instead of eight RAS cycles are necessary for proper operation of CAS before RAS refresh mode.

SELF REFRESH SPECIFICATIONS

Self refresh devices are denoted by "S" after speed item, like -5S/ -6S/ -7S. The other characteristics and requirements than the below are same as normal devices.

TIMING REQUIREMENTS (Ta=0~70°C, Vcc=5.0V±10%, Vss=0V, unless otherwise noted, see notes 13,14)

Symbol	Parameter	Limits						Unit
		M5M416160C-5S		M5M416160C-6S		M5M416160C-7S		
		Min	Max	Min	Max	Min	Max	
trASS	Self refresh RAS low pulse width	100		100		100		μs
trPS	Self refresh RAS high precharge time	90		110		130		ns
tCHS	Self refresh RAS hold time	- 50		- 50		- 50		ns

SELF REFRESH ENTRY & EXIT CONDITIONS

(1) In case of distributed refresh

The last / first full refresh cycles (4K) must be made within tns / tsn before / after self refresh, on the condition of tns ≤ 64ms and tsn ≤ 64ms.

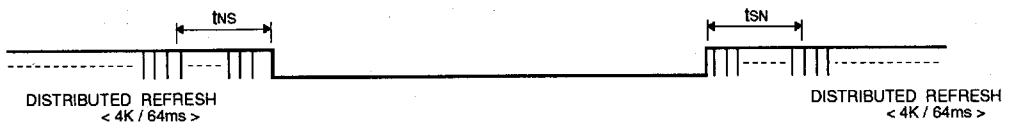

(2) In case of burst refresh

The last / first full refresh cycles (4K) must be made within tns / tsn before / after self refresh, on the condition of tns + tsn ≤ 64ms.

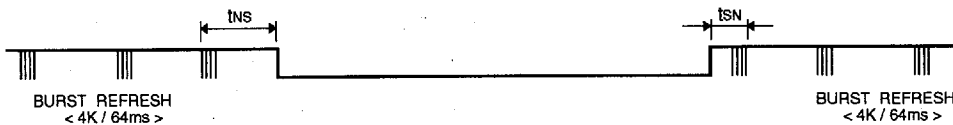

6249825 0028808 418



PRELIMINARY

Notice: This is not a final specification.
Some parametric limits are subject to change.

FAST PAGE MODE 1677216-BIT (1048576-WORD BY 16-BIT) DYNAMIC RAM

Timing Diagrams (Note 28)

Read Cycle

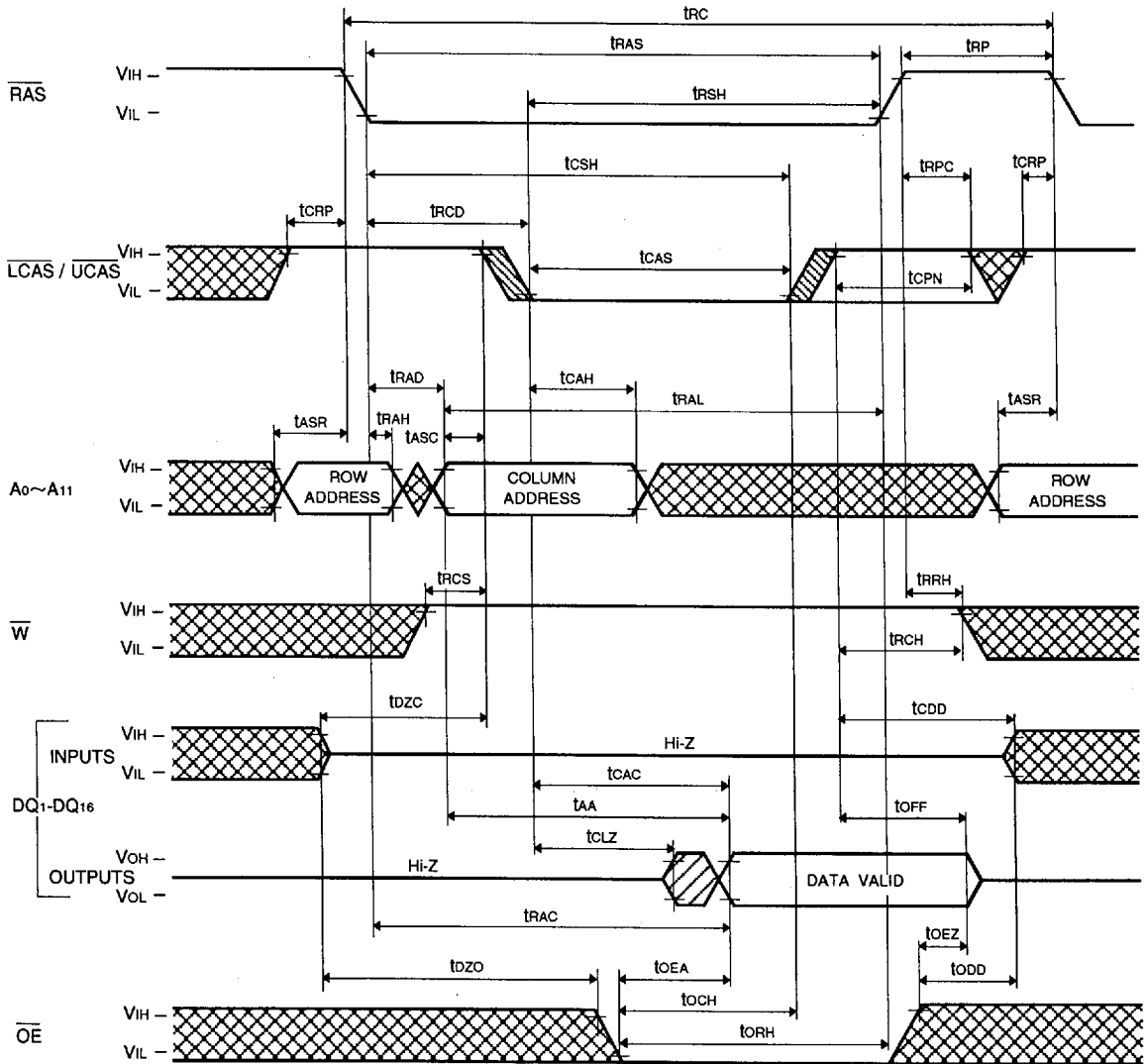

Note 28



Indicates the don't care input.
 $V_{IH}(\min.) \leq V_{IN} \leq V_{IH}(\max.)$ or $V_{IL}(\min.) \leq V_{IN} \leq V_{IL}(\max.)$

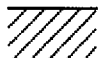

Indicates the invalid output.



Indicates the skew of the two inputs.

PRELIMINARY

Notice: This is not a final specification.
Some parametric limits are subject to change.

FAST PAGE MODE 1677216-BIT (1048576-WORD BY 16-BIT) DYNAMIC RAM

Upper / (Lower) Byte Read Cycle

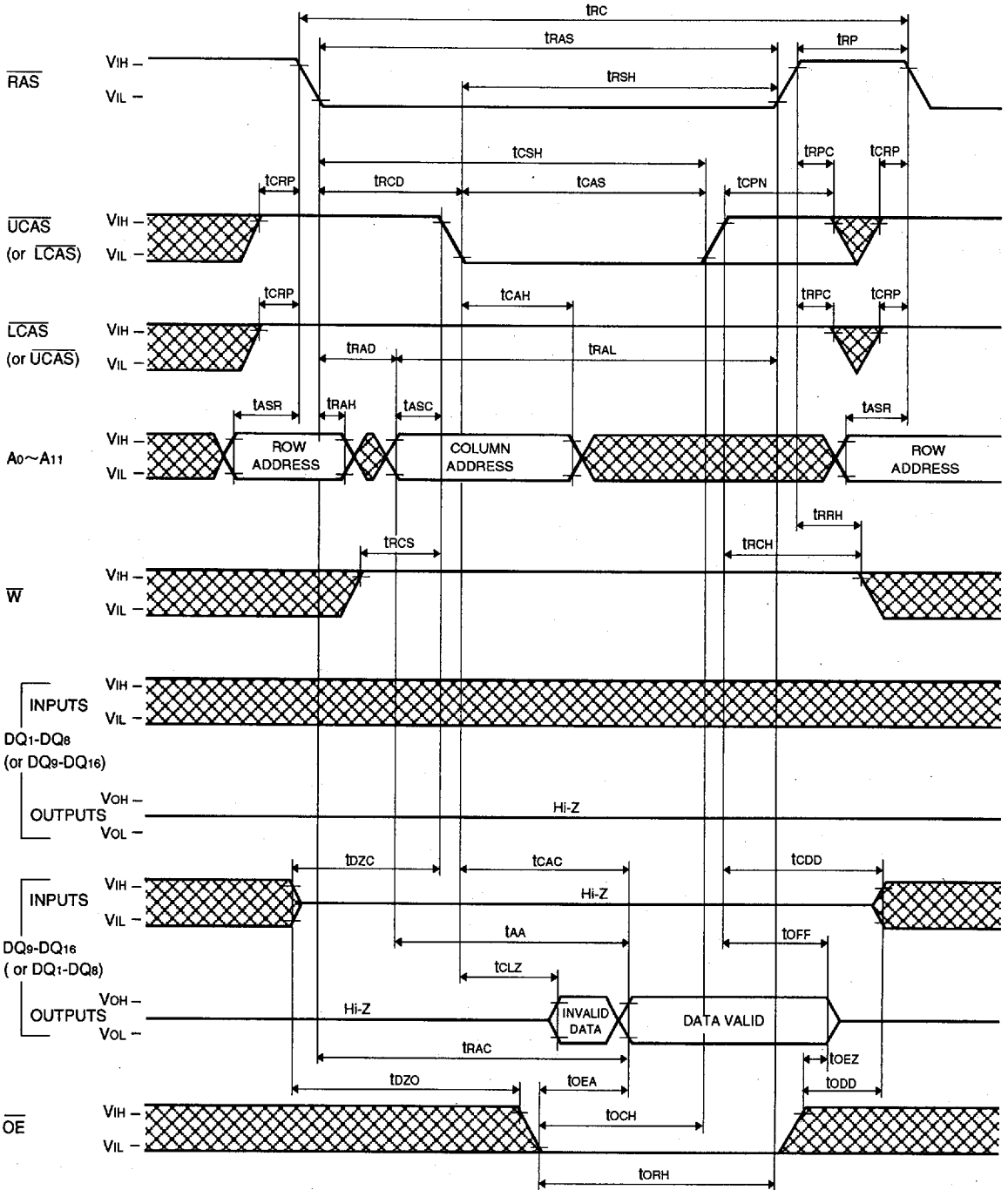

6249825 0028810 076



PRELIMINARY

Notice: This is not a final specification.
Some parametric limits are subject to change.

FAST PAGE MODE 1677216-BIT (1048576-WORD BY 16-BIT) DYNAMIC RAM

Write Cycle (Early write)

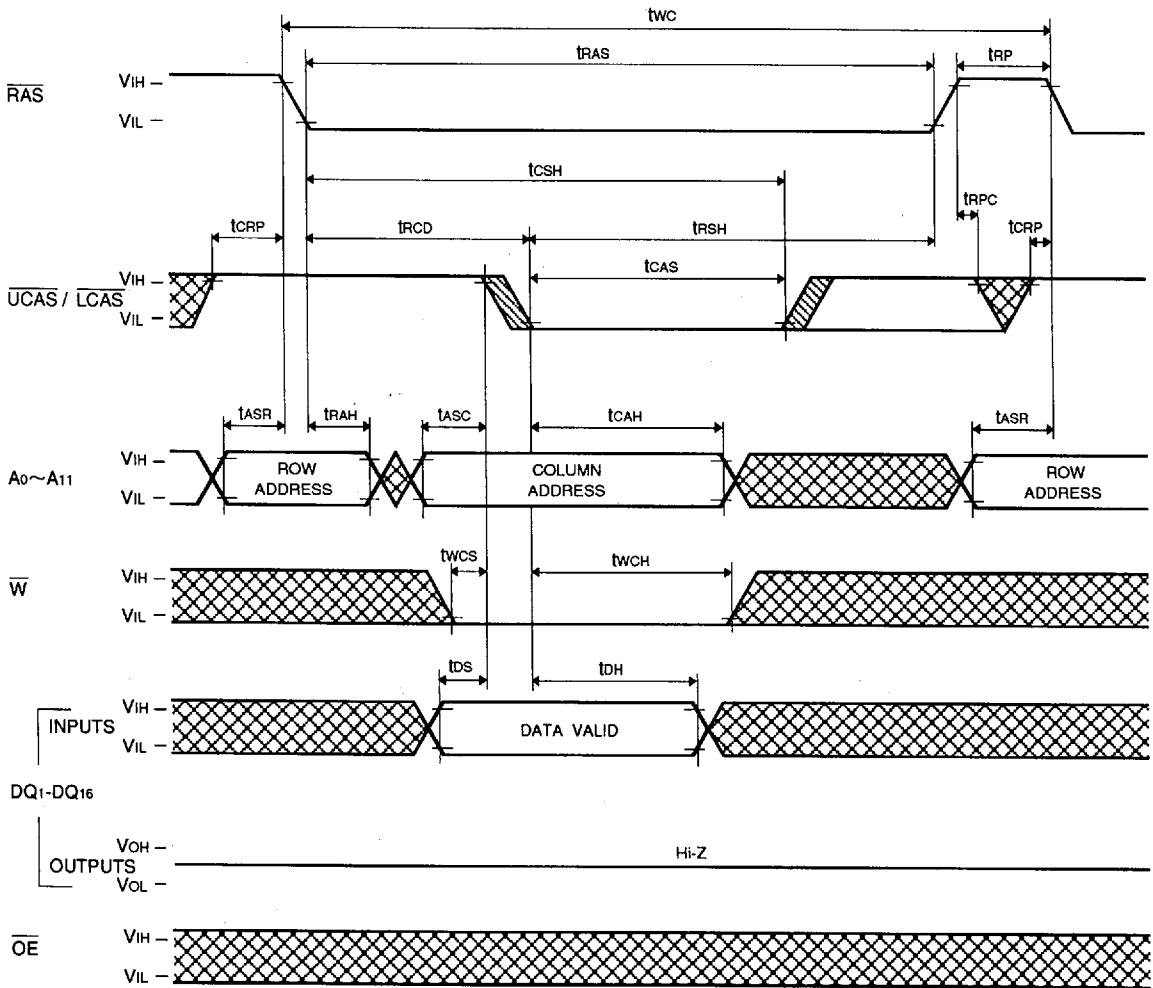

■ 6249825 0028811 T02 ■

PRELIMINARY

Notice: This is not a final specification.
Some parametric limits are subject to change.

M5M416160CJ,TP-5,-6,-7,-5S,-6S,-7S

FAST PAGE MODE 1677216-BIT (1048576-WORD BY 16-BIT) DYNAMIC RAM

Upper / (Lower) Byte Write Cycle (Early write)

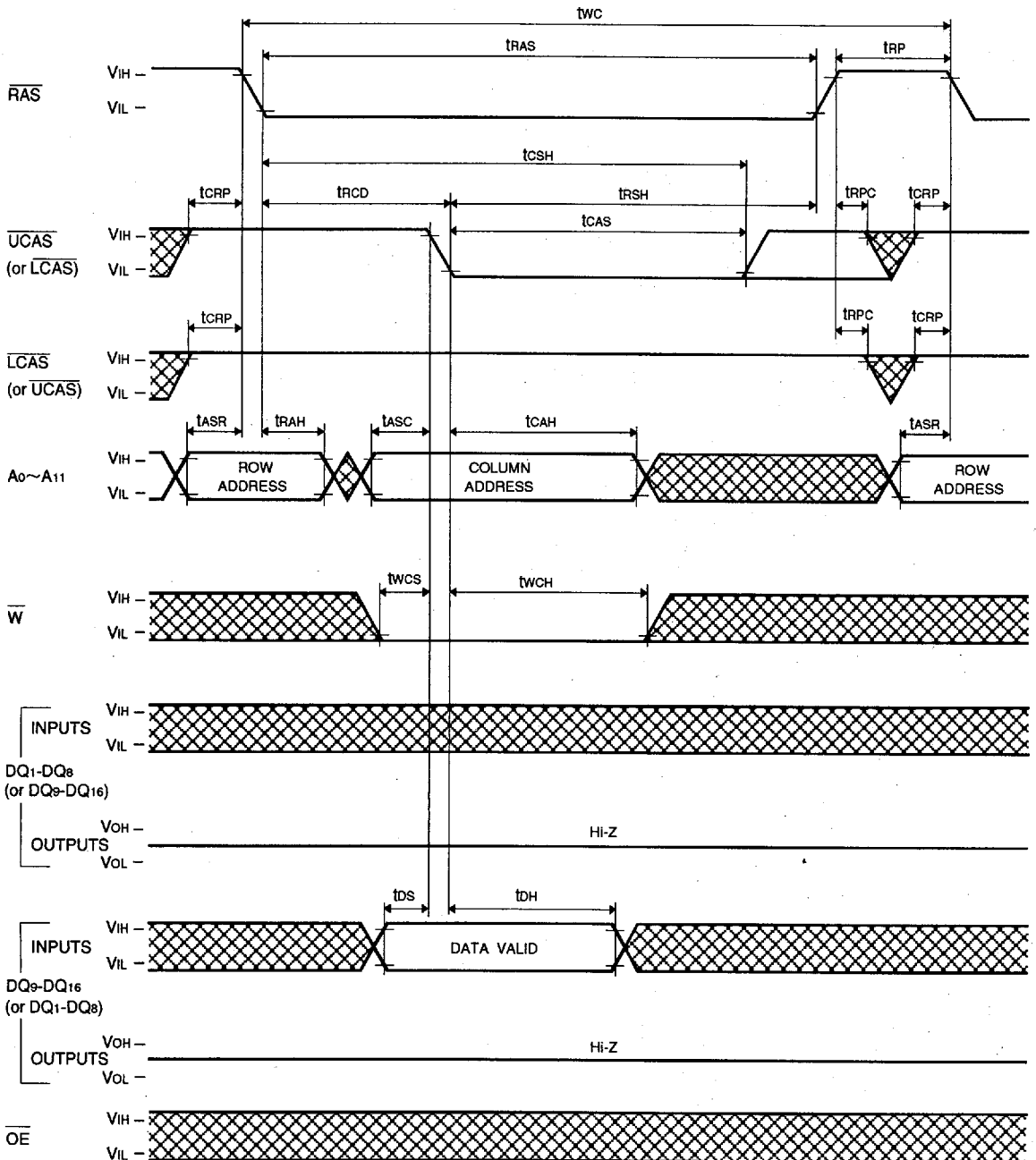

6249825 0028812 949

PRELIMINARY

Notice: This is not a final specification.
Some parametric limits are subject to change.

FAST PAGE MODE 1677216-BIT (1048576-WORD BY 16-BIT) DYNAMIC RAM

Write Cycle (Delayed write)

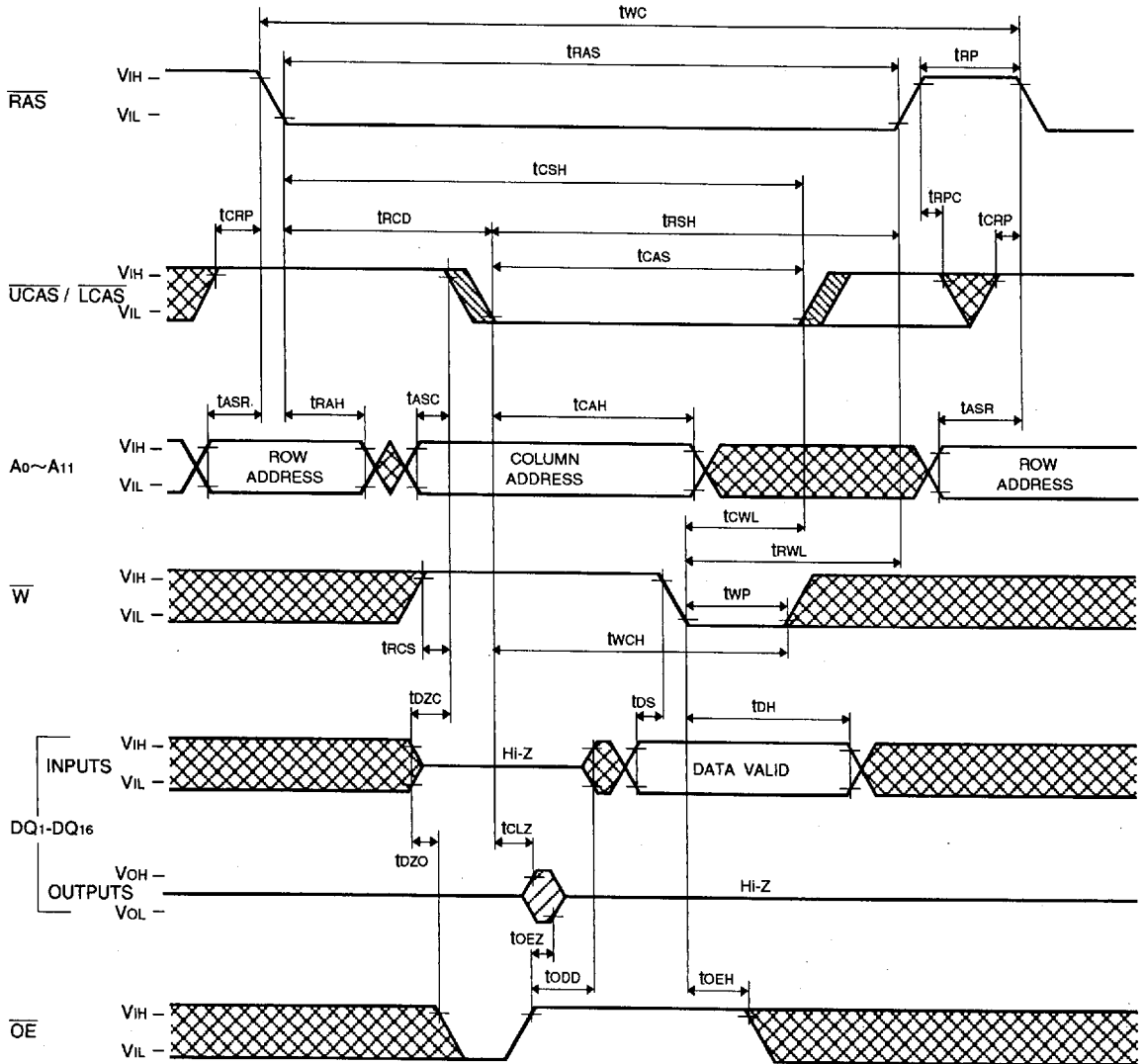

6249825 0028813 885



PRELIMINARY
 Notice: This is not a final specification.
 Some parametric limits are subject to change.

FAST PAGE MODE 1677216-BIT (1048576-WORD BY 16-BIT) DYNAMIC RAM

Upper / (Lower) Byte Write Cycle (Delayed write)

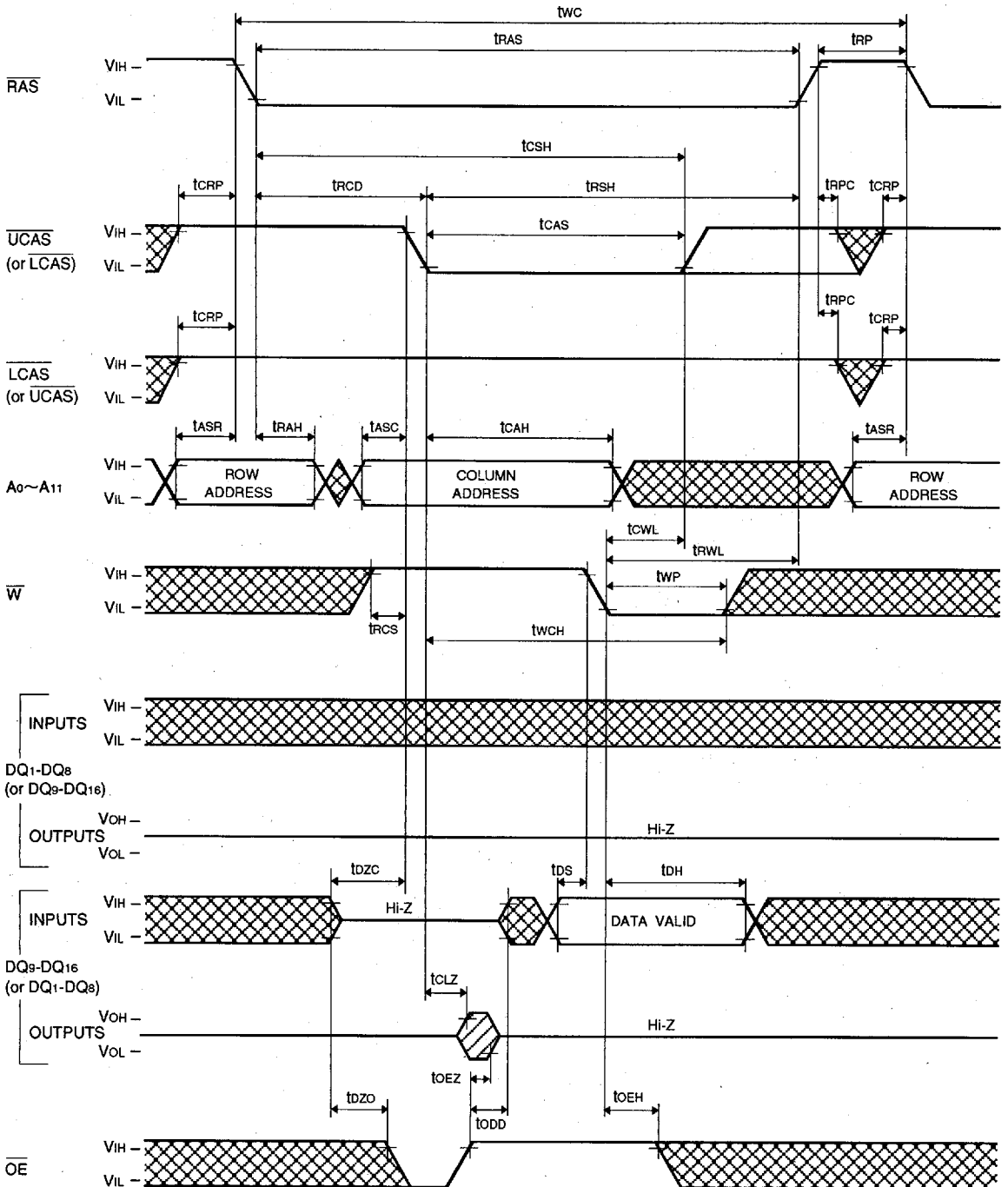

6249825 0028814 711

PRELIMINARY

Notice: This is not a final specification.
Some parametric limits are subject to change.

FAST PAGE MODE 1677216-BIT (1048576-WORD BY 16-BIT) DYNAMIC RAM

Read-Write, Read-Modify-Write Cycle

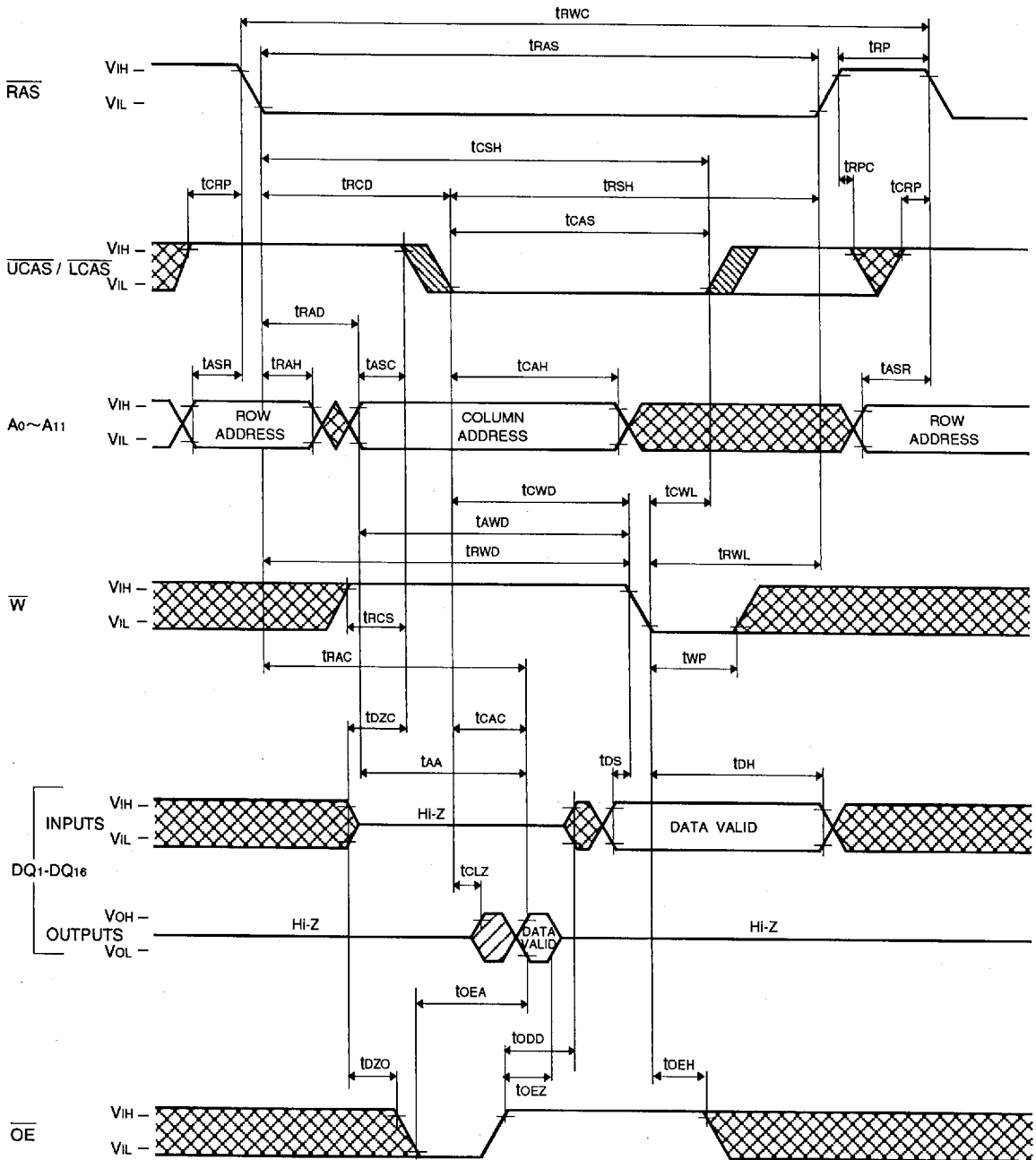

6249825 0028815 658



PRELIMINARY

Notice: This is not a final specification.
Some parametric limits are subject to change.

FAST PAGE MODE 1677216-BIT (1048576-WORD BY 16-BIT) DYNAMIC RAM

RAS-only Refresh Cycle

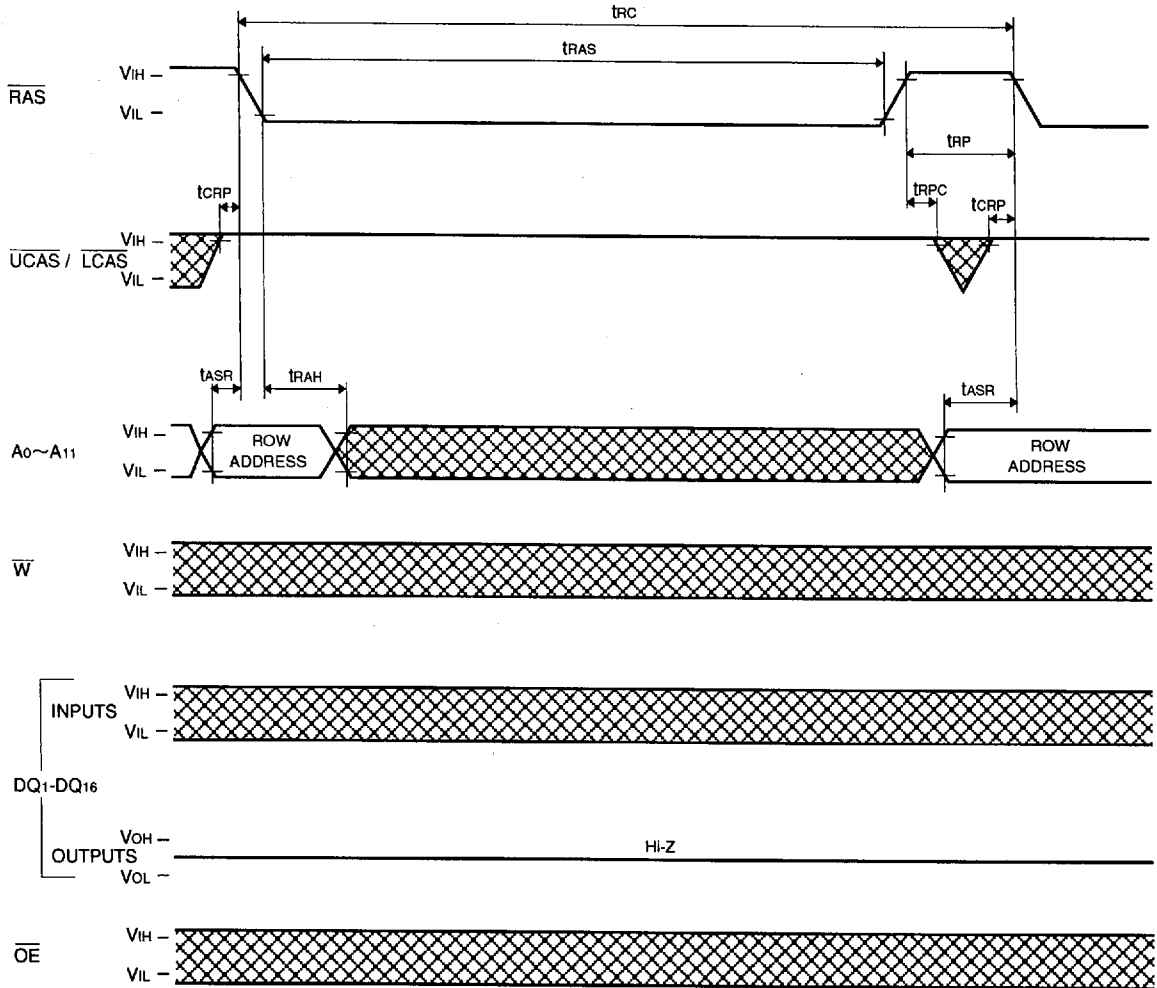

6249825 0028817 420

PRELIMINARY
 Notice: This is not a final specification.
 Some parametric limits are subject to change

FAST PAGE MODE 1677216-BIT (1048576-WORD BY 16-BIT) DYNAMIC RAM

CAS before RAS Refresh Cycle, Extended Refresh Cycle*

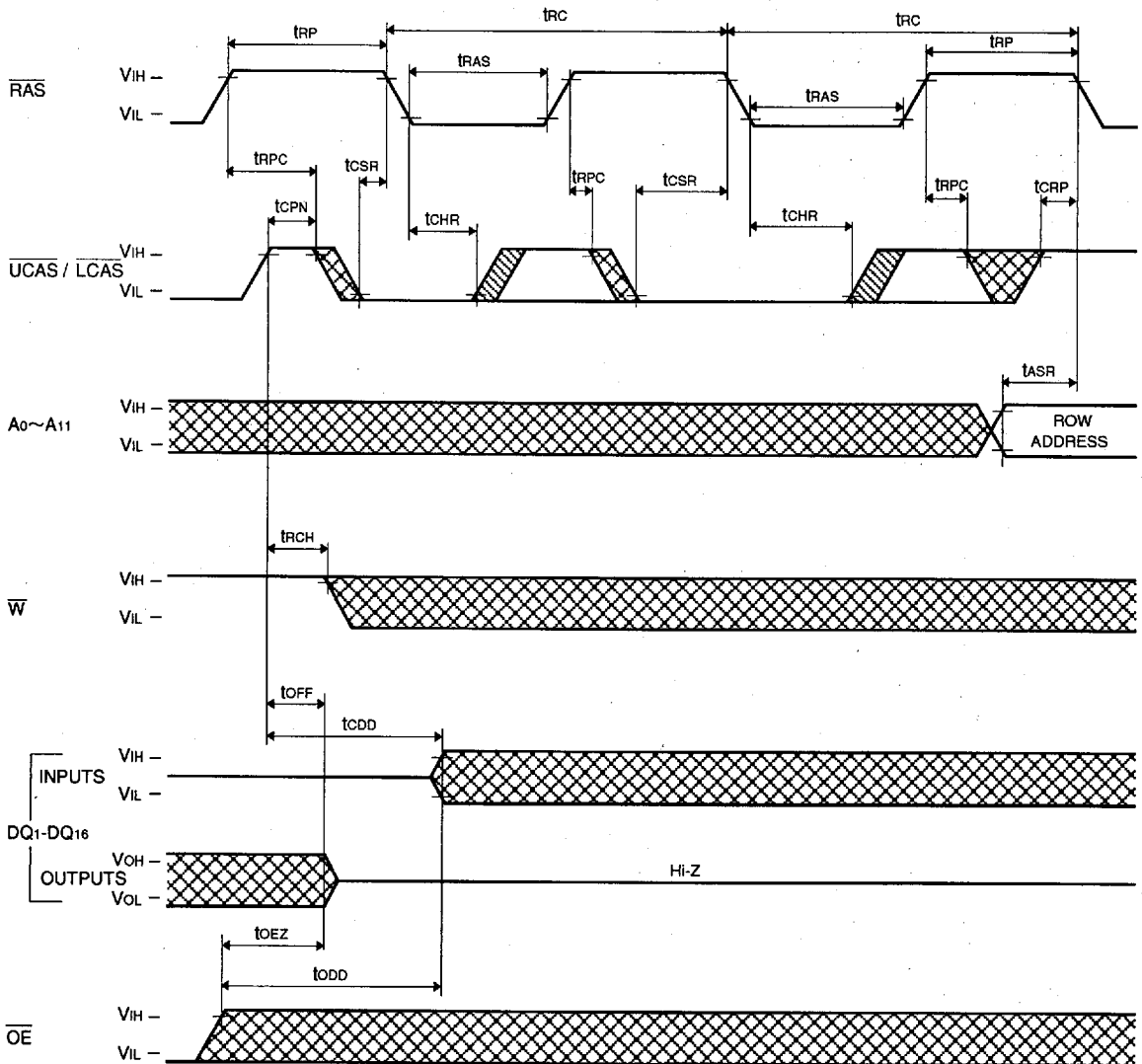

6249825 0028818 367

PRELIMINARY

Notice: This is not a final specification.
Some parametric limits are subject to change.

MITSUBISHI LSIs M5M416160CJ, TP-5, -6, -7, -5S, -6S, -7S

FAST PAGE MODE 1677216-BIT (1048576-WORD BY 16-BIT) DYNAMIC RAM

Upper / (Lower) CAS before RAS Refresh Cycle, Extended Refresh Cycle *

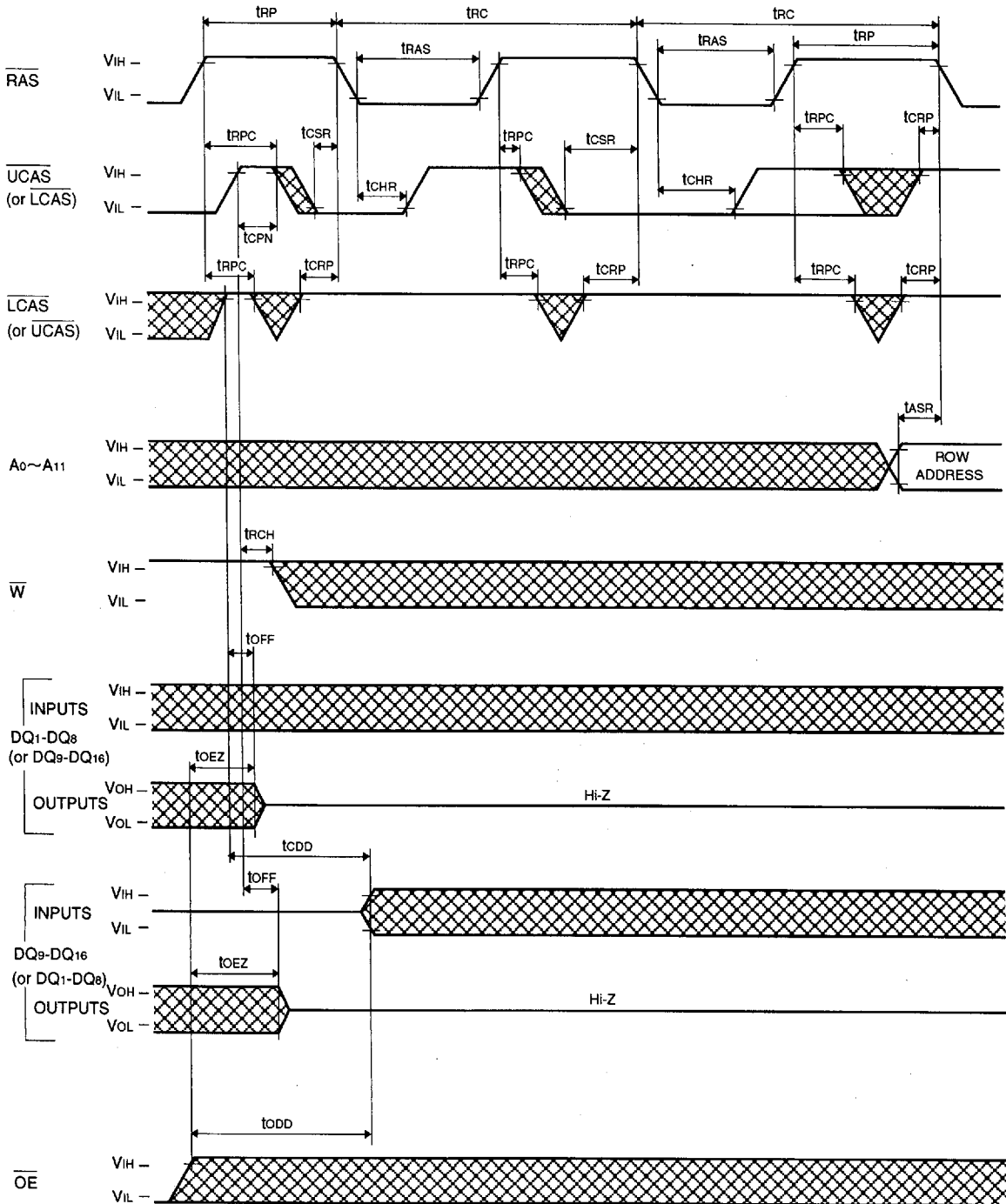

6249825 0028819 2T3

PRELIMINARY
 Notice: This is not a final specification.
 Some parametric limits are subject to change.

FAST PAGE MODE 1677216-BIT (1048576-WORD BY 16-BIT) DYNAMIC RAM

Hidden Refresh Cycle (Read) (Note 29)

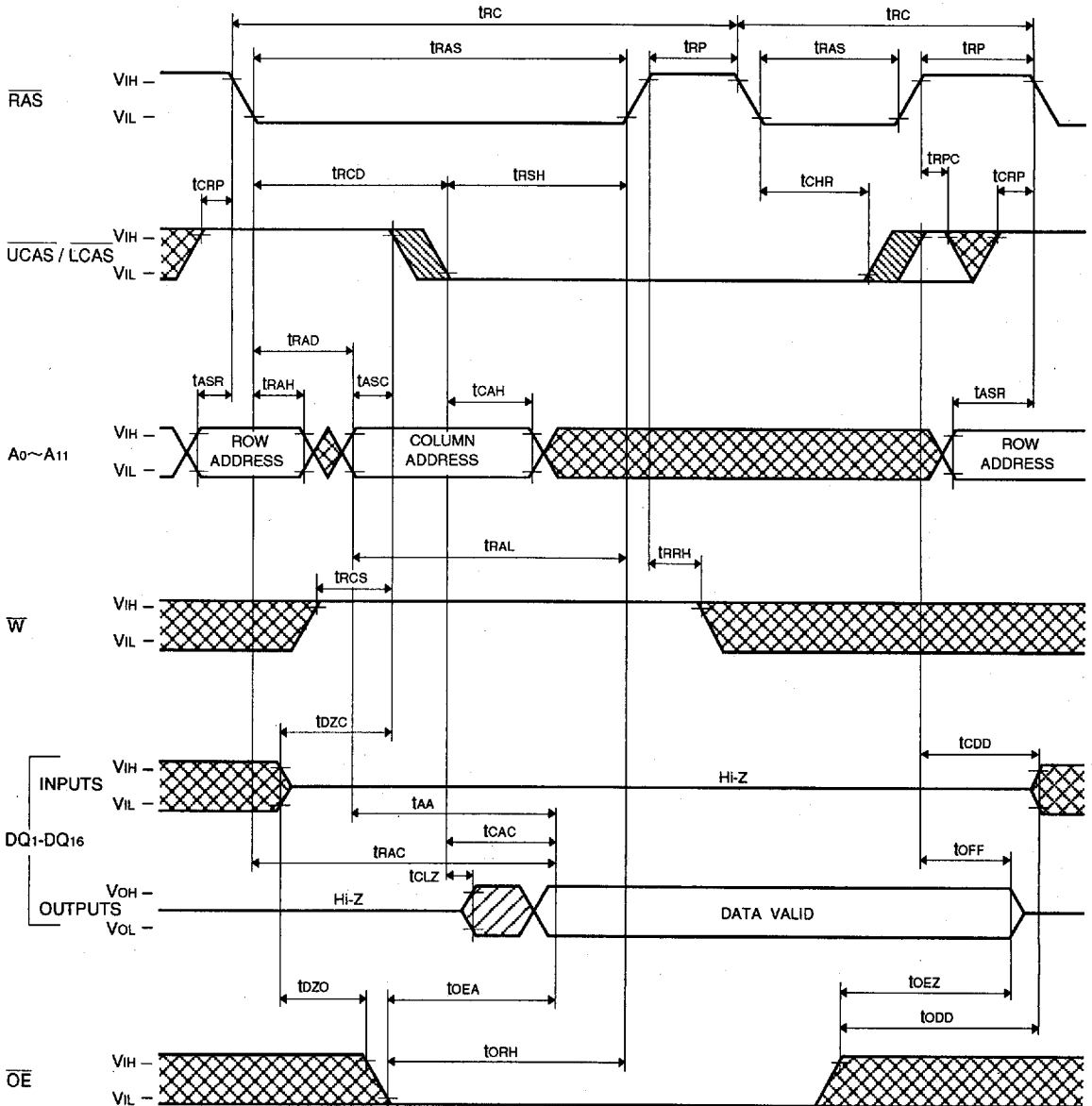

Note 29: Early write, delayed write, read write or read modify write cycle is applicable instead of read cycle.
 Timing requirements and output state are the same as that of each cycle shown above.

6249825 0028820 T15



PRELIMINARY

Notice: This is not a final specification.
Some parametric limits are subject to change.

M5M416160CJ, TP-5, -6, -7, -5S, -6S, -7S

MITSUBISHI LSIs

FAST PAGE MODE 1677216-BIT (1048576-WORD BY 16-BIT) DYNAMIC RAM

Upper / (Lower) Hidden Refresh Cycle (Byte Read) (Note 29)

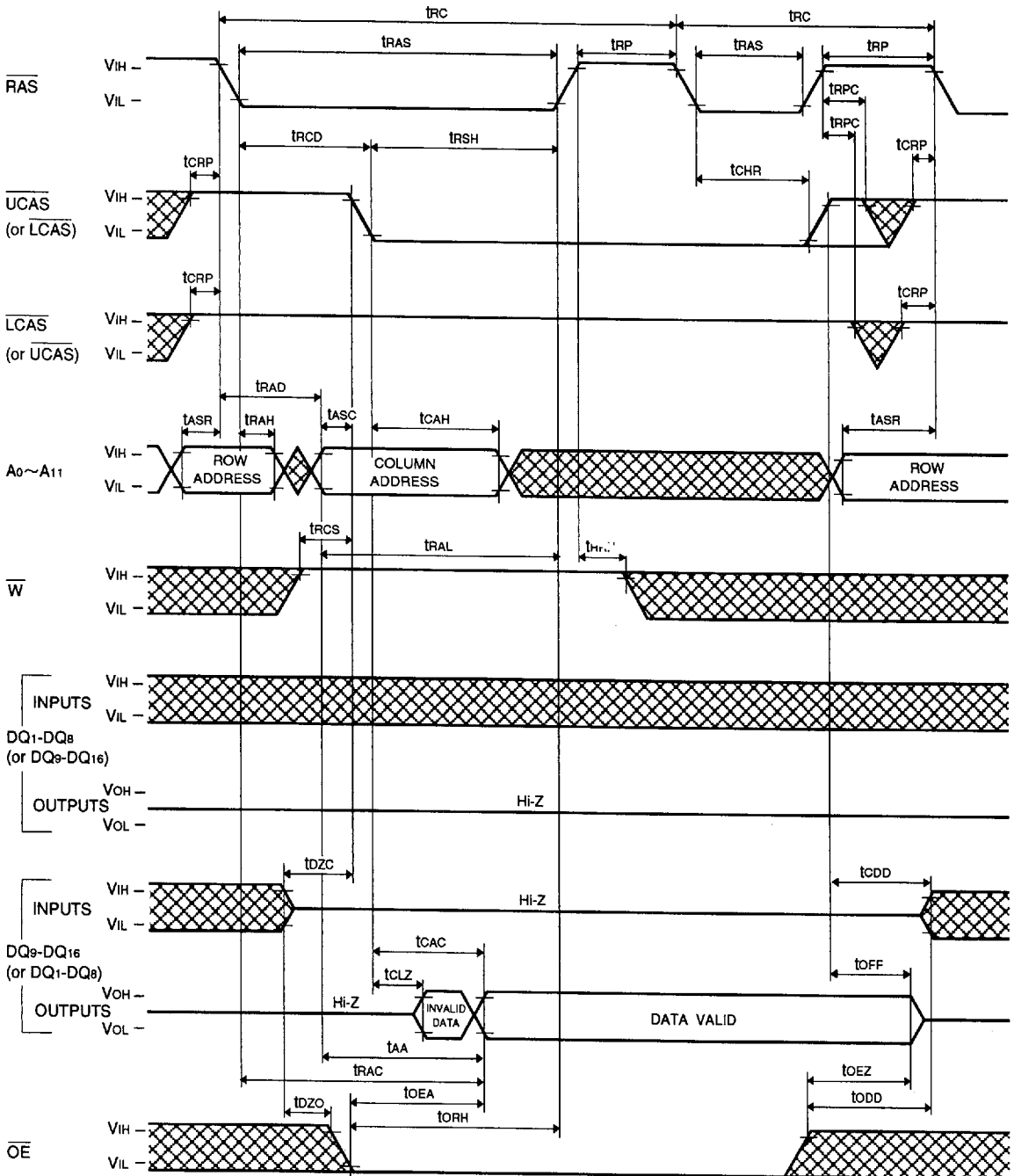

Note 29: Early write, delayed write, read write or read modify write cycle is applicable instead of read cycle.
Timing requirements and output state are the same as that of each cycle shown above.

6249825 0028821 951



PRELIMINARY

Notice: This is not a final specification.
Some parametric limits are subject to change.

MITSUBISHI LSIs

M5M416160CJ, TP-5,-6,-7,-5S,-6S,-7S

FAST PAGE MODE 16777216-BIT (1048576-WORD BY 16-BIT) DYNAMIC RAM

Fast Page Mode Read Cycle

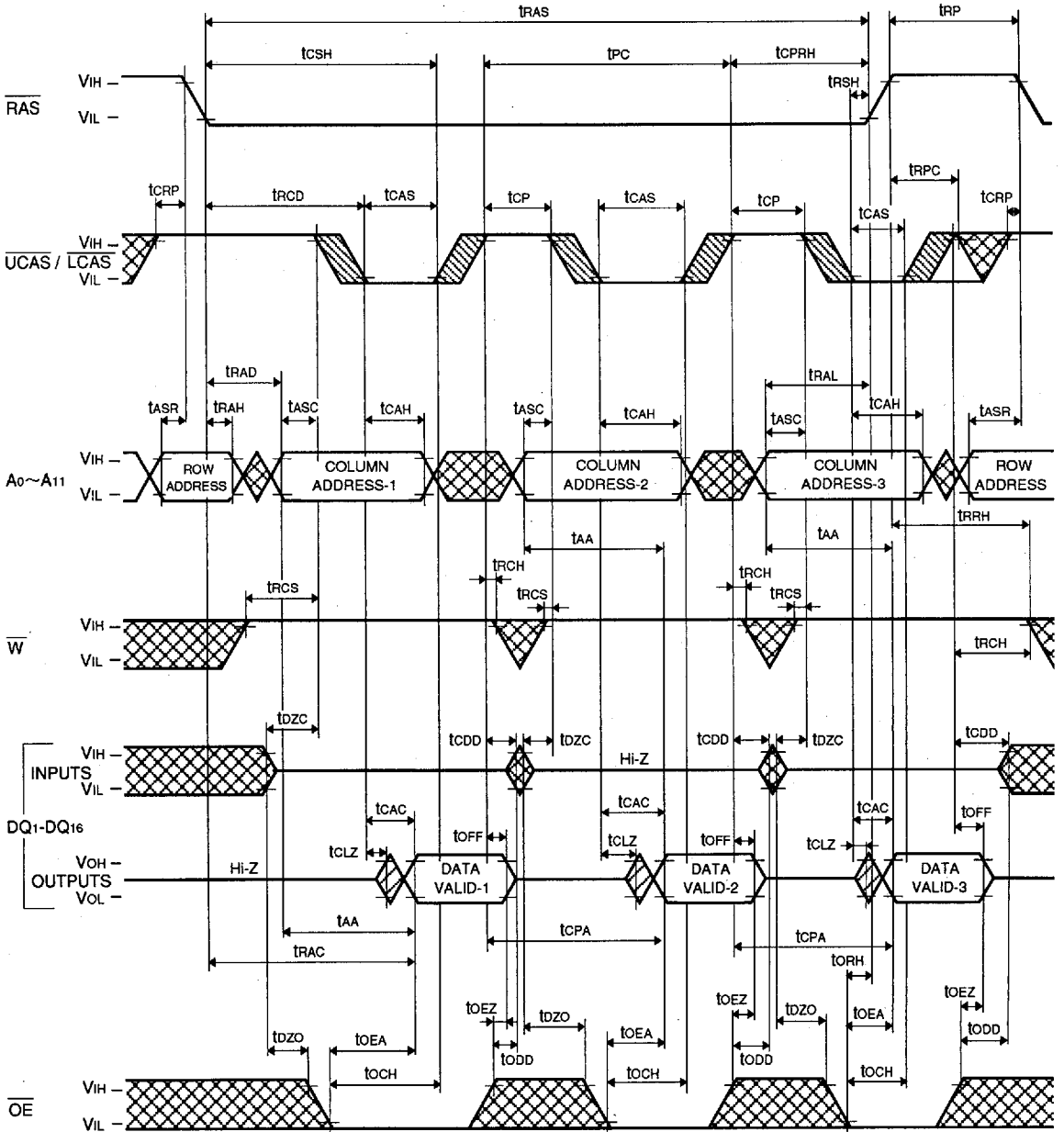

6249825 0028822 898



PRELIMINARY
 Notice: This is not a final specification.
 Some parametric limits are subject to change.

FAST PAGE MODE 1677216-BIT (1048576-WORD BY 16-BIT) DYNAMIC RAM

Fast Page Mode Write Cycle (Early Write)

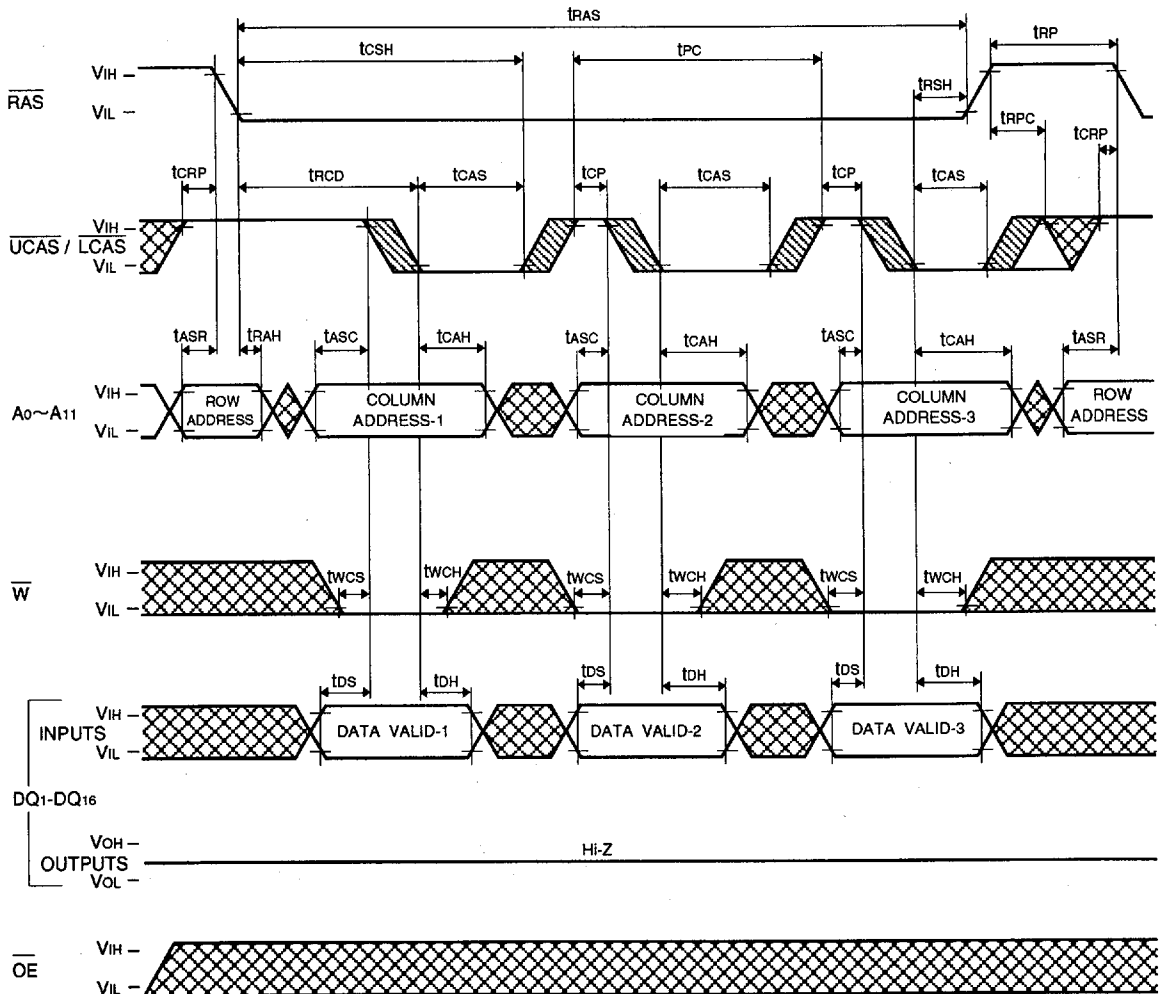

6249825 0028824 660

PRELIMINARY

Notice: This is not a final specification.
Some parametric limits are subject to change.

FAST PAGE MODE 1677216-BIT (1048576-WORD BY 16-BIT) DYNAMIC RAM

Fast Page Mode Upper / (Lower) Byte Write Cycle (Early Write)

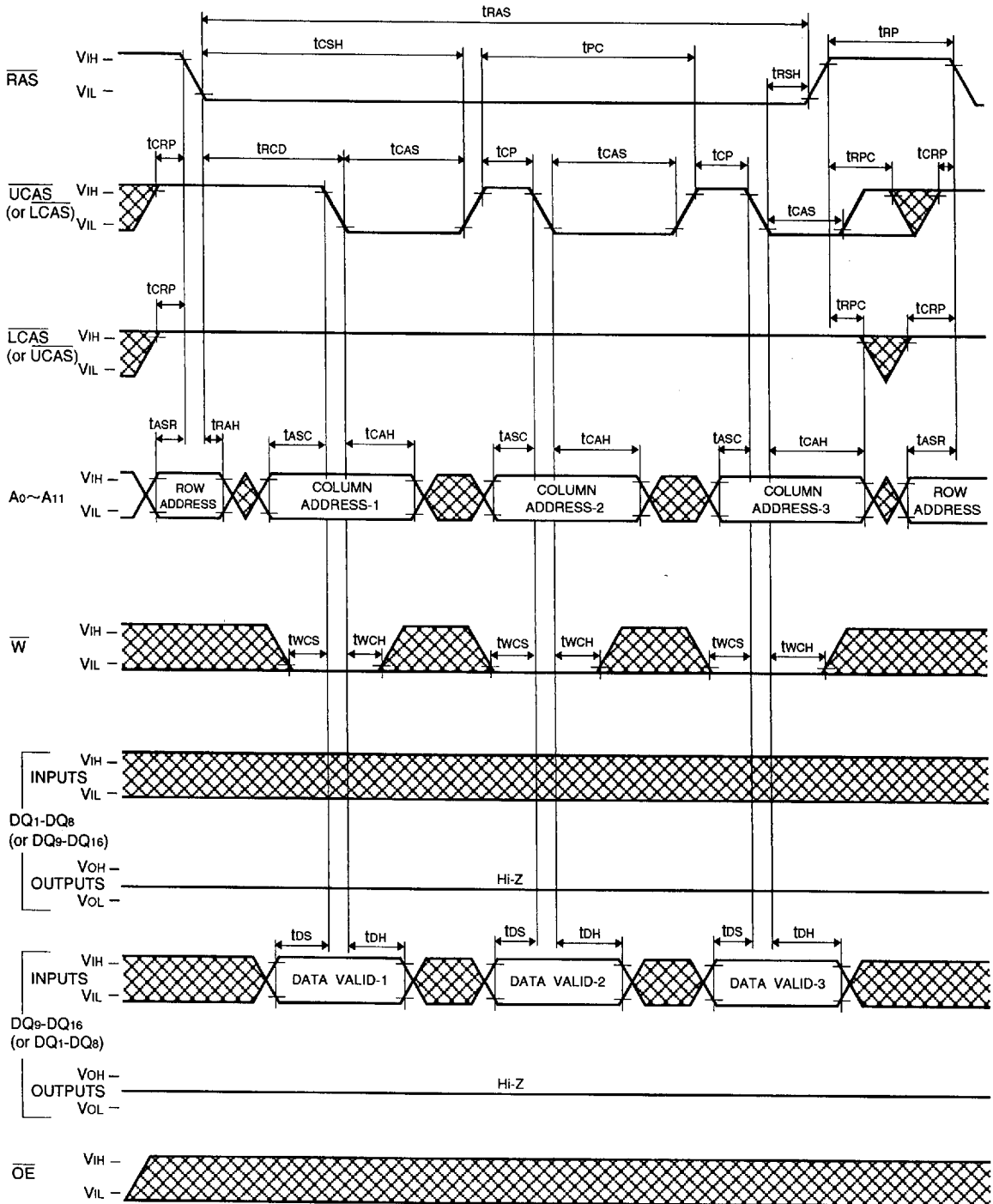

6249825 0028825 5T7



PRELIMINARY

Note: This is not a final specification.
Some parametric limits are subject to change.

FAST PAGE MODE 1677216-BIT (1048576-WORD BY 16-BIT) DYNAMIC RAM

Fast Page Mode Write Cycle (Delayed Write)

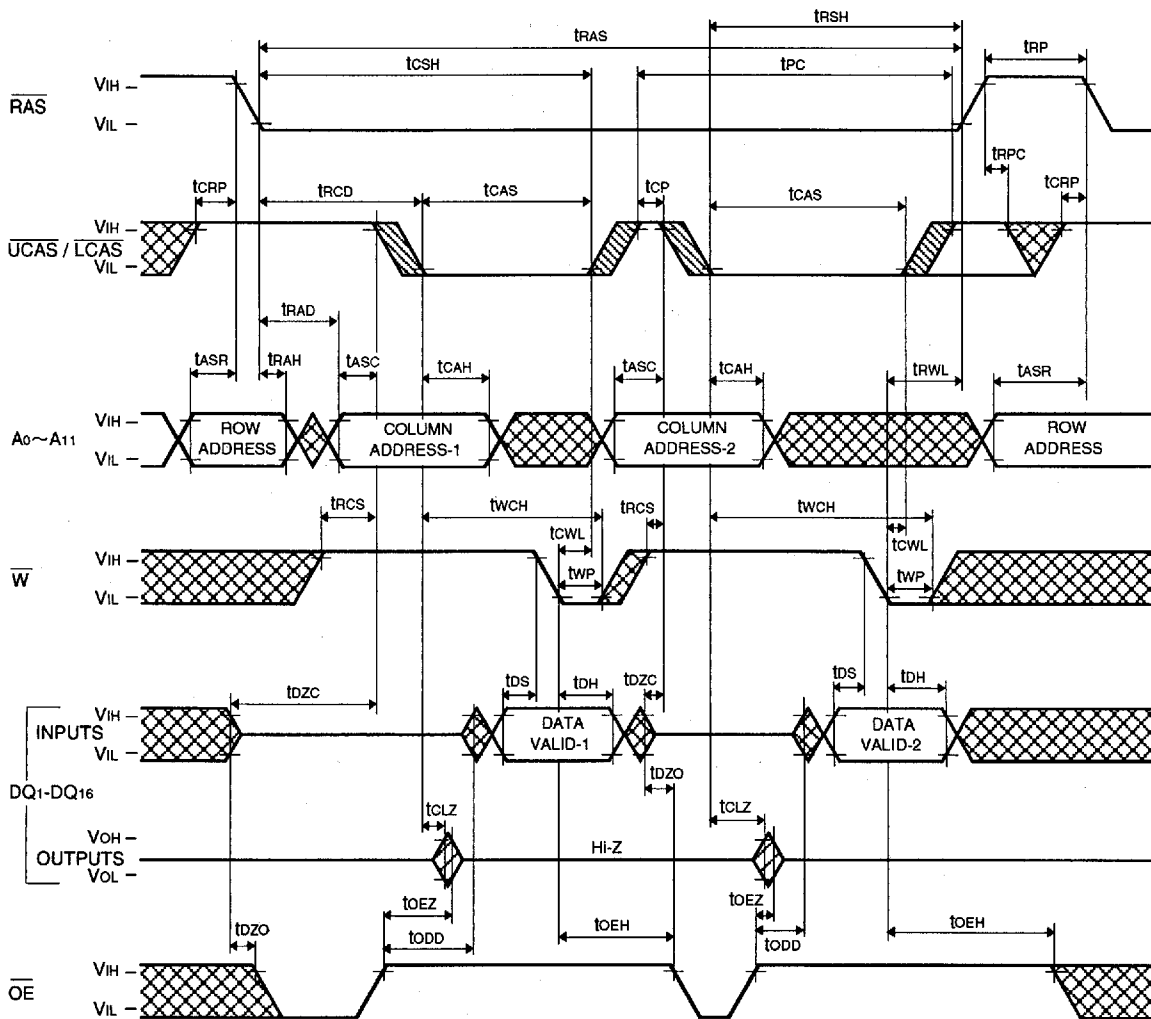

6249825 0028826 433

PRELIMINARY

Notice: This is not a final specification.
Some parametric limits are subject to change.

MITSUBISHI LSIs M5M416160CJ, TP-5, -6, -7, -5S, -6S, -7S

FAST PAGE MODE 1677216-BIT (1048576-WORD BY 16-BIT) DYNAMIC RAM

Fast Page Mode Upper / (Lower) Byte Write Cycle (Delayed Write)

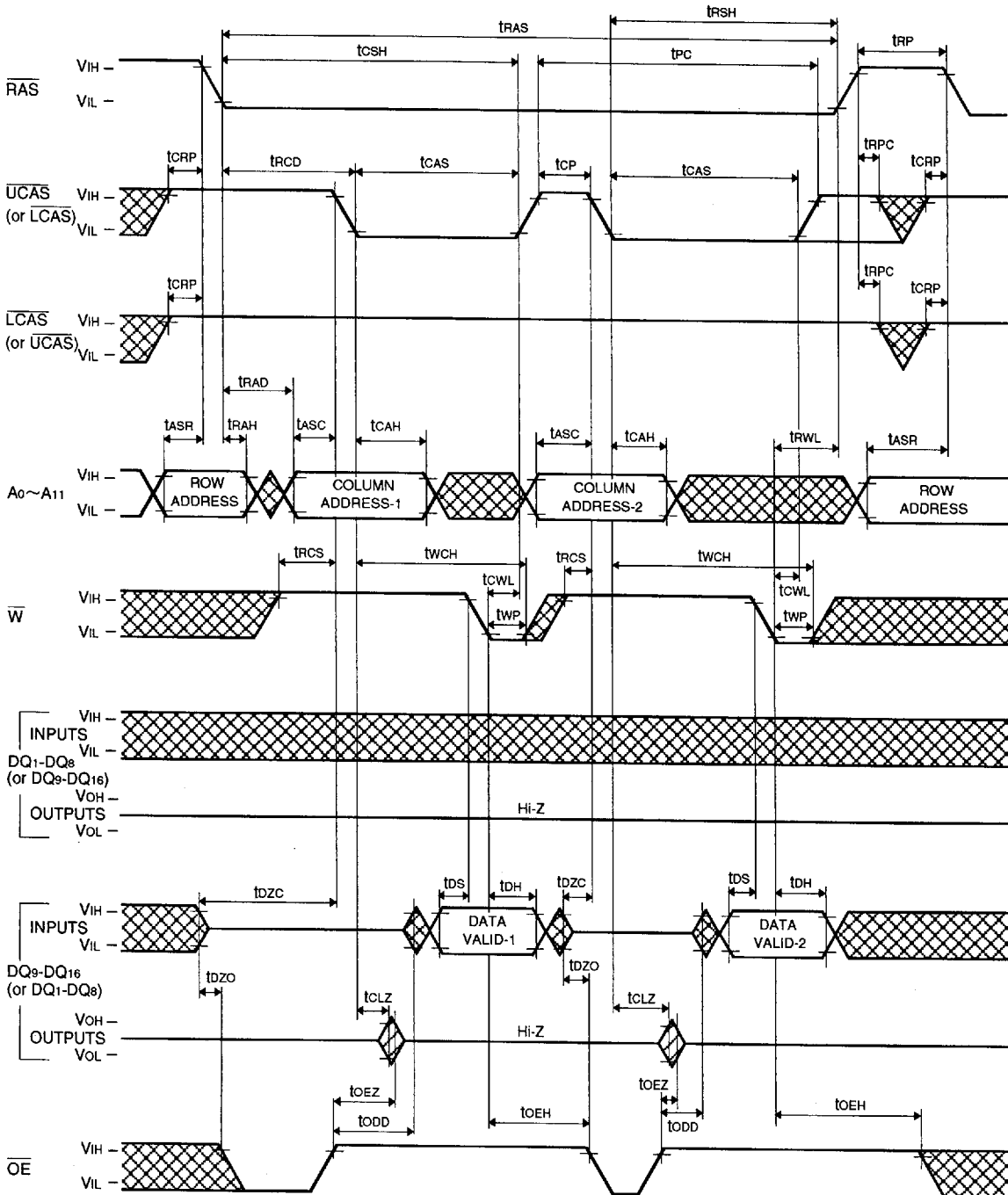

6249825 0028827 37T



PRELIMINARY

Notice: This is not a final specification.
Some parametric limits are subject to change.

M5M416160CJ, TP-5, -6, -7, -5S, -6S, -7S

FAST PAGE MODE 1677216-BIT (1048576-WORD BY 16-BIT) DYNAMIC RAM

Fast Page Mode Read-Write, Read-Modify-Write Cycle

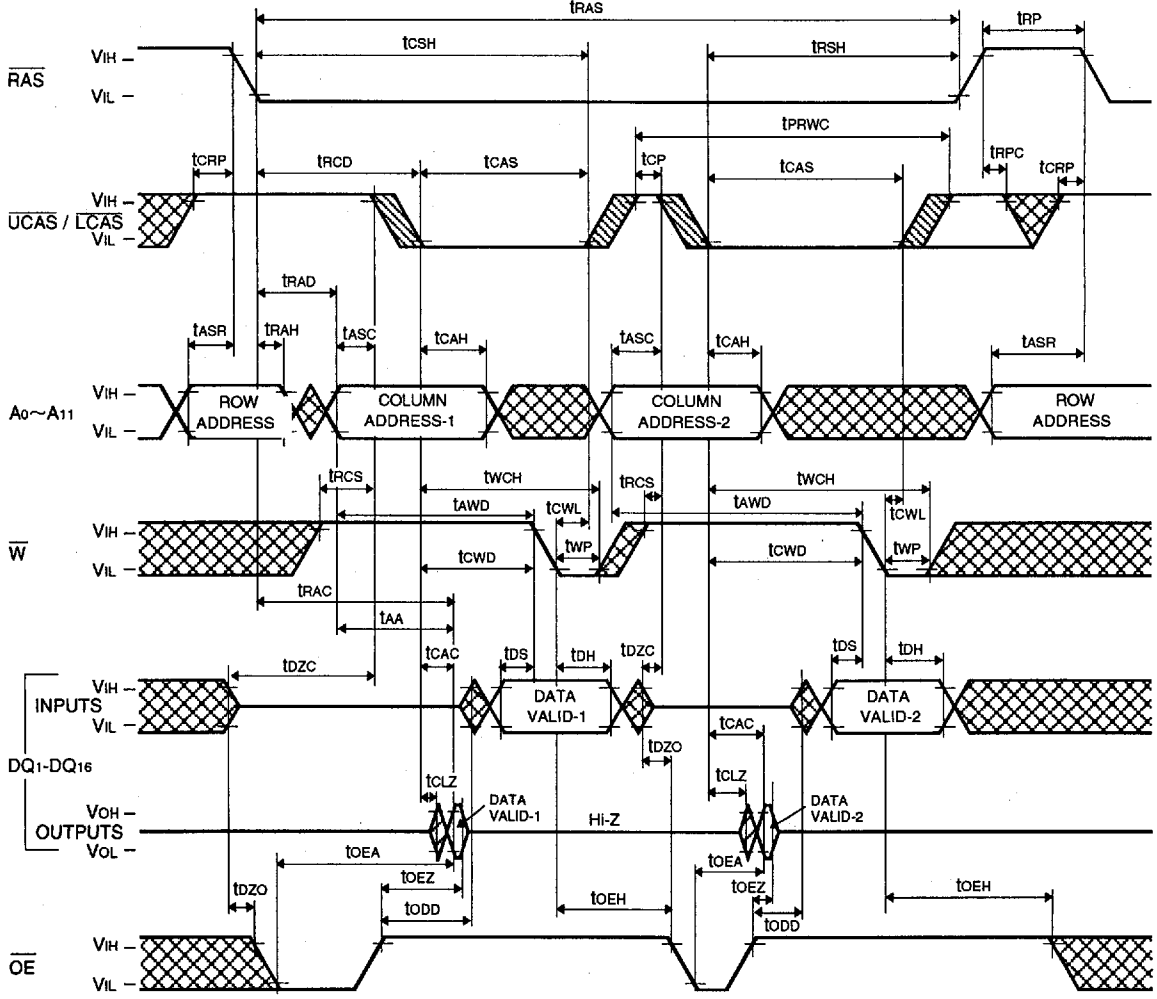

6249825 0028828 206



PRELIMINARY

Notice: This is not a final specification.
Some parametric limits are subject to change.

FAST PAGE MODE 1677216-BIT (1048576-WORD BY 16-BIT) DYNAMIC RAM

Fast Page Mode Read-Upper / (Lower) Write, Read-Modify-Upper / (Lower) Write Cycle

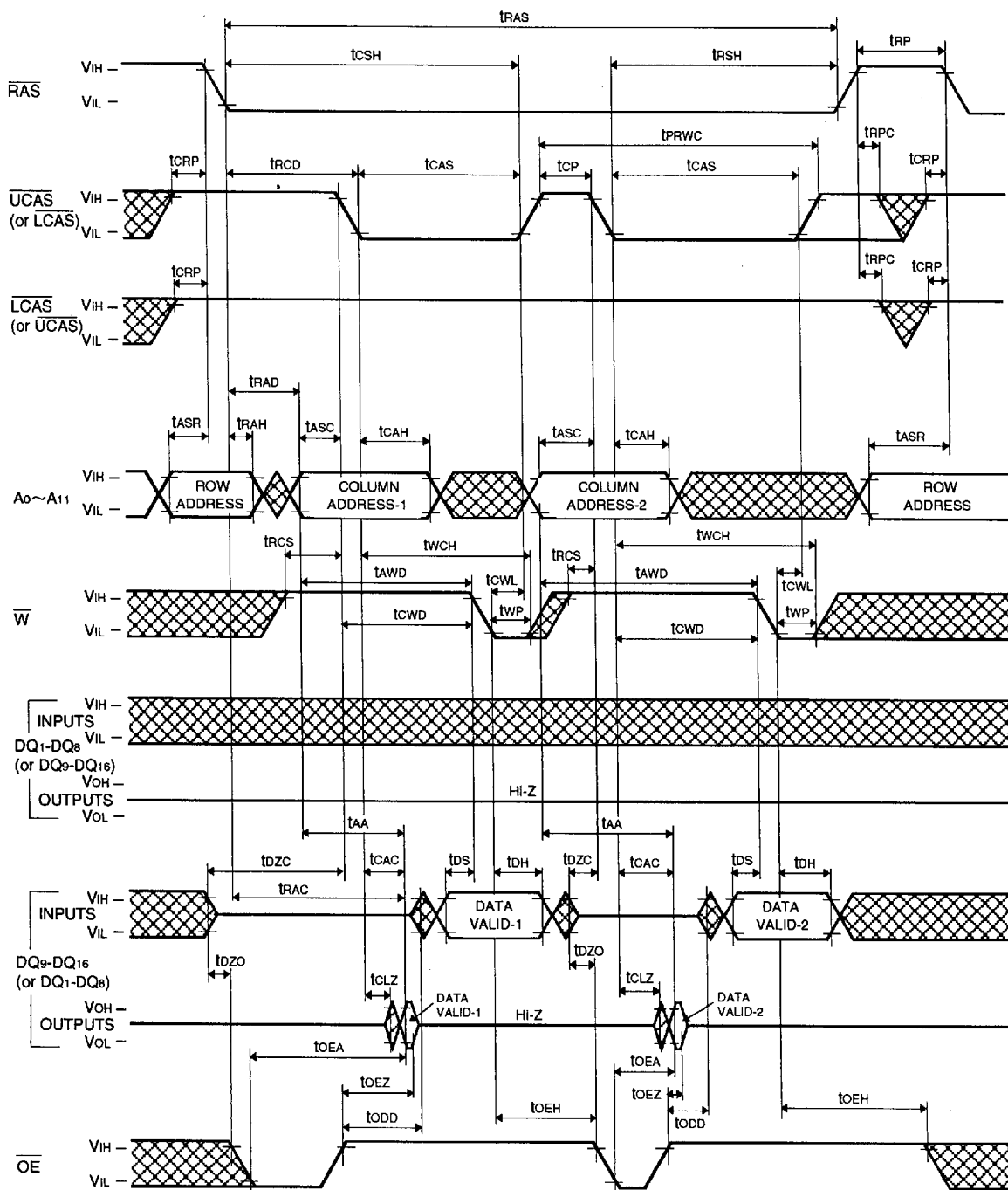

6249825 0028829 142

PRELIMINARY

Notice: This is not a final specification.
Some parametric limits are subject to change

FAST PAGE MODE 1677216-BIT (1048576-WORD BY 16-BIT) DYNAMIC RAM

Self Refresh Cycle*

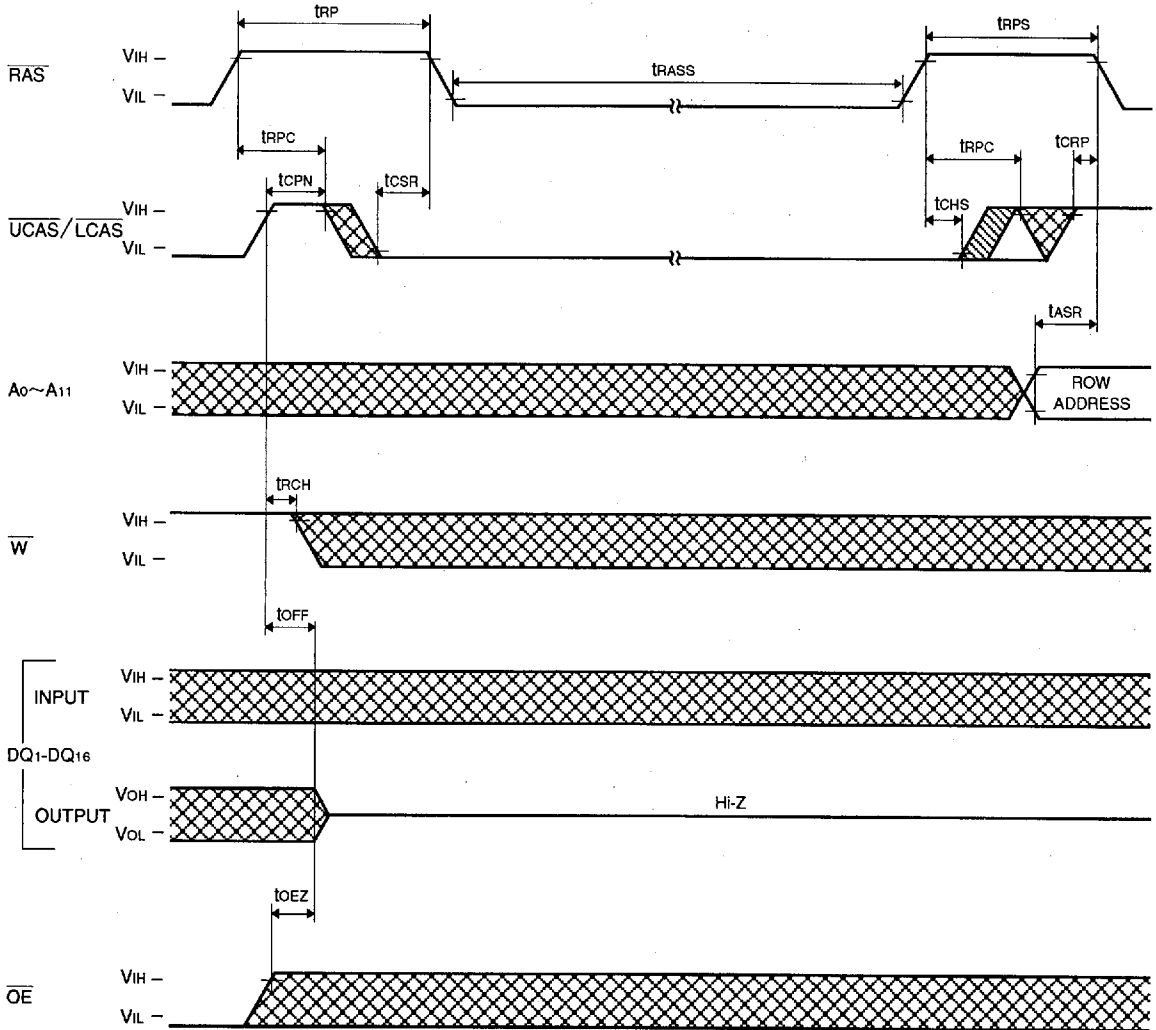

6249825 0028830 964

PRELIMINARY

Notice: This is not a final specification.
Some parameter limits are subject to change

FAST PAGE MODE 16777216-BIT (1048576-WORD BY 16-BIT) DYNAMIC RAM

Upper / (Lower) Self Refresh Cycle*

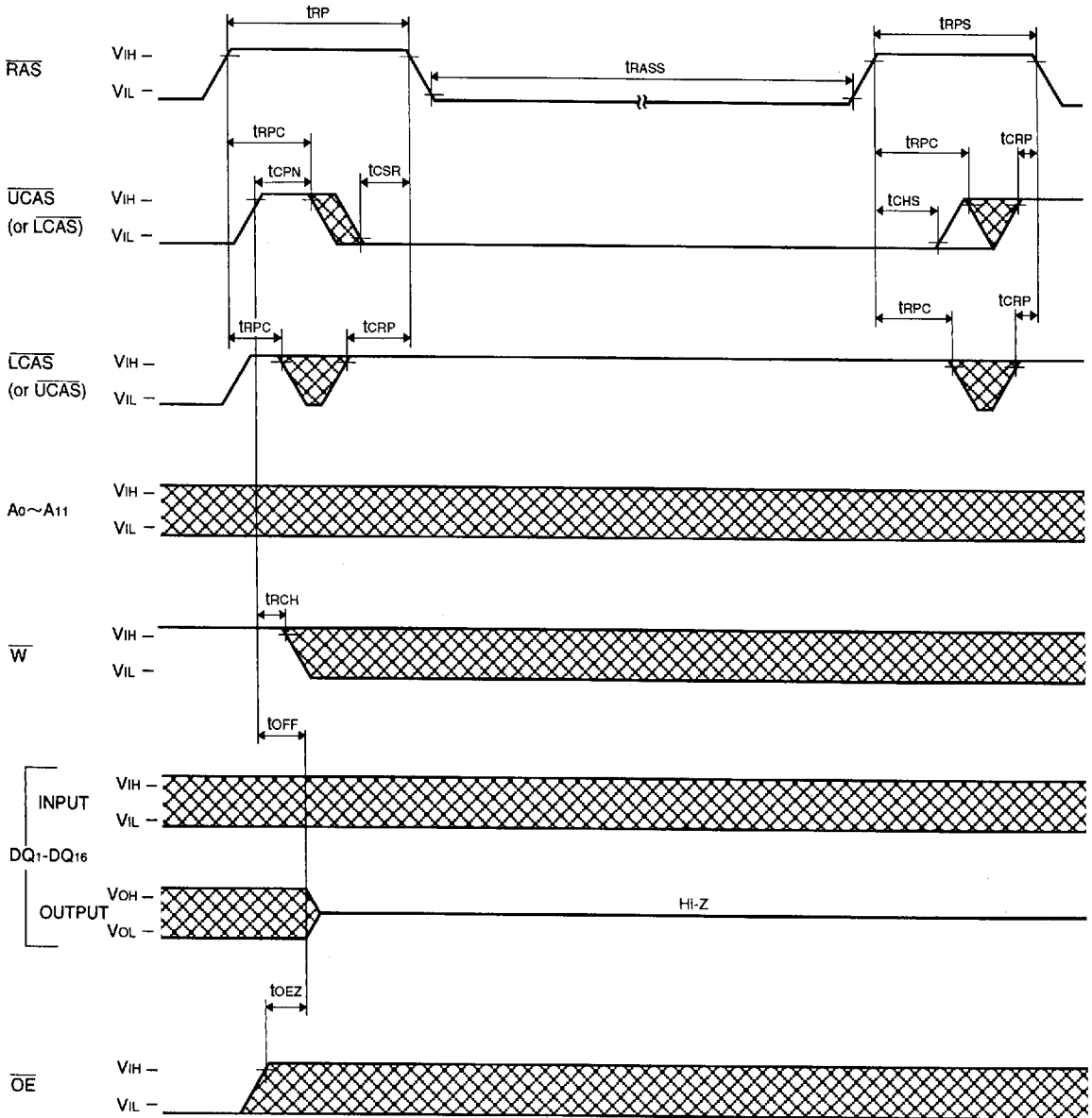

■ 6249825 0028831 8T0 ■