

NEW SYNCBURST FLOW-THROUGH - 2.5V I/O

GENERAL DESCRIPTION (continued)

Burst operation can be initiated with either address status processor (ADSP#) or address status controller (ADSC#) input pins. Subsequent burst addresses can be internally generated as controlled by the burst advance pin (ADV#).

Address and write control are registered on-chip to simplify WRITE cycles. This allows self-timed WRITE cycles. Individual byte enables allow individual bytes to be written. BW1# controls DQ1-DQ8 and DQP1, BW2# controls DQ9-DQ16 and DQP2, BW3# controls DQ17-DQ24 and DQP3, and BW4# controls DQ25-DQ32 and DQP4, conditioned by

BWE# being LOW. GW# LOW causes all bytes to be written. Parity bits are available in the x36 version only.

The MT58LC128K32/36E1 operates from a +3.3V power supply and all inputs and outputs can communicate with other 2.5V I/O. All inputs are 3.3V-tolerant and can be used in mixed 3.3V and 2.5V systems. The device is ideally suited for systems that benefit from a wide synchronous data bus and 2.5V I/O. The device is also ideal in generic 32-, 36-, 64- and 72-bit-wide applications.

FUNCTIONAL BLOCK DIAGRAM
128K x 32

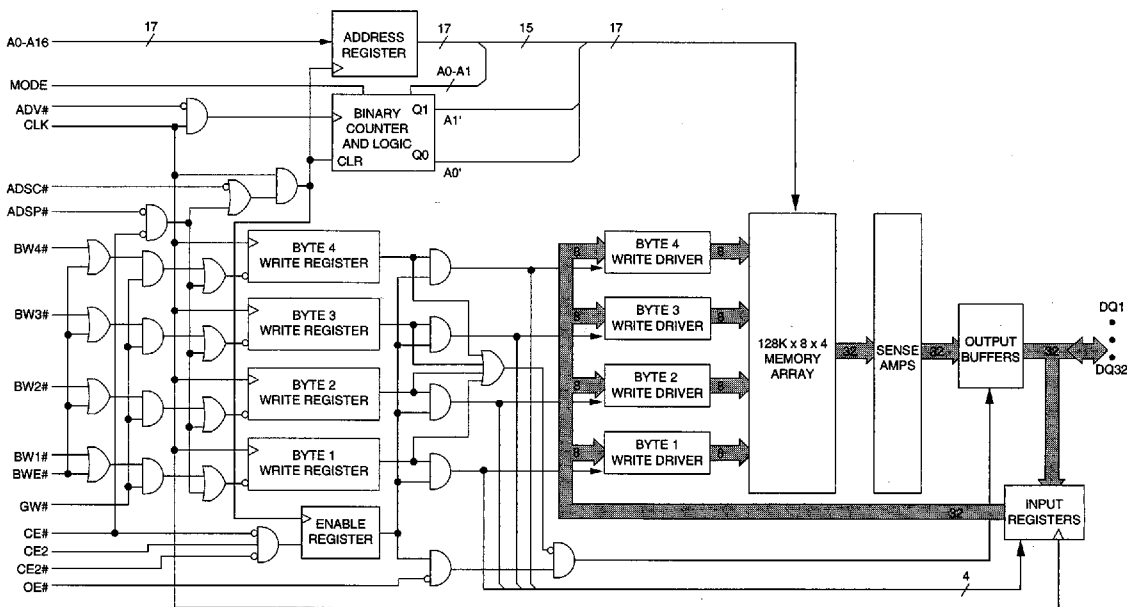

NOTE: 1. Functional Block Diagrams illustrate simplified device operation. See Truth Table, Pin Descriptions and timing diagrams for detailed information.

FUNCTIONAL BLOCK DIAGRAM
128K x 36

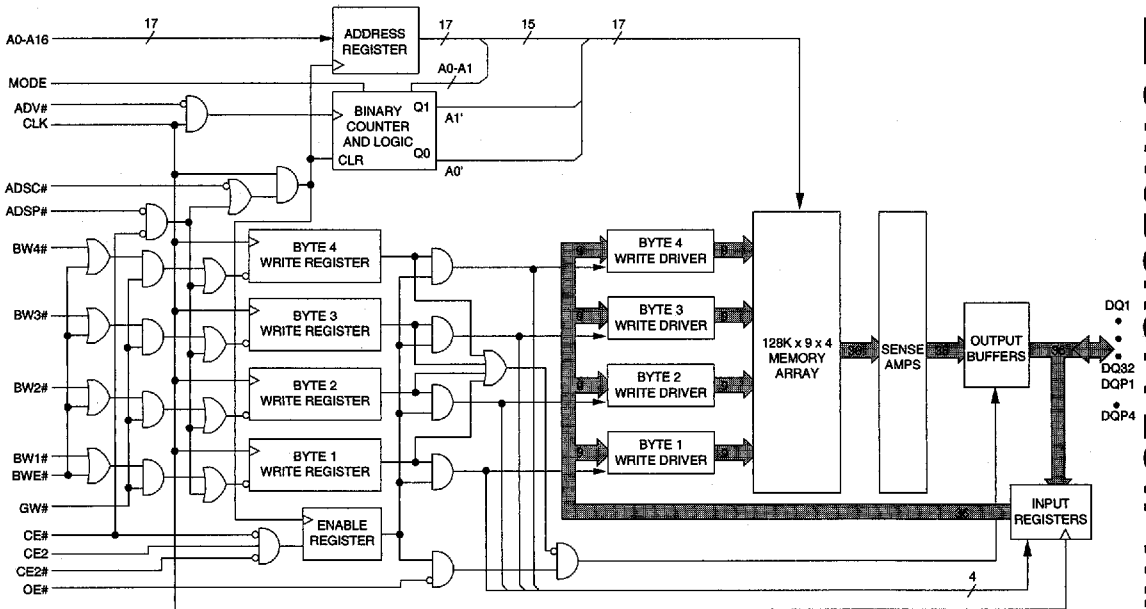

PIN DESCRIPTIONS

TQFP PINS	SYMBOL	TYPE	DESCRIPTION
37, 36, 35, 34, 33, 32, 100, 99, 82, 81, 44, 45, 46, 47, 48, 49, 50	A0-A16	Input	Synchronous Address Inputs: These inputs are registered and must meet the setup and hold times around the rising edge of CLK.
93, 94, 95, 96	BW1#, BW2#, BW3#, BW4#	Input	Synchronous Byte Write Enables: These active LOW inputs allow individual bytes to be written when BWE# is LOW and must meet the setup and hold times around the rising edge of CLK. A Byte Write Enable is LOW for a WRITE cycle and HIGH for a READ cycle. BW1# controls DQ1-DQ8 and DQP1. BW2# controls DQ9-DQ16 and DQP2. BW3# controls DQ17-DQ24 and DQP3. BW4# controls DQ25-DQ32 and DQP4. Data I/O are tristated if any of these four inputs are LOW.
89	CLK	Input	Clock: This signal registers the address, data, chip enables, byte write enables and burst control inputs on its rising edge. All synchronous inputs must meet setup and hold times around the clock's rising edge.
98	CE#	Input	Synchronous Chip Enable: This active LOW input is used to enable the device and conditions the internal use of ADSP#. This input is sampled only when a new external address is loaded.
92	CE2#	Input	Synchronous Chip Enable: This active LOW input is used to enable the device. This input is sampled only when a new external address is loaded. This input can be used for memory depth expansion.
97	CE2	Input	Synchronous Chip Enable: This active HIGH input is used to enable the device. This input is sampled only when a new external address is loaded. This input can be used for memory depth expansion.
86	OE#	Input	Output Enable: This active LOW asynchronous input enables the data I/O output drivers.
83	ADV#	Input	Synchronous Address Advance: This active LOW input is used to advance the internal burst counter, controlling burst access after the external address is loaded. A HIGH on this pin effectively causes wait states to be generated (no address advance). This pin must be HIGH at the rising edge of the first clock after an ADSP# cycle is initiated if a WRITE cycle is desired (to ensure use of correct address).
84	ADSP#	Input	Synchronous Address Status Processor: This active LOW input interrupts any ongoing burst, causing a new external address to be registered. A READ is performed using the new address, independent of the byte write enables and ADSC#, but dependent upon CE2 and CE2#. ADSP# is ignored if CE# is HIGH. Power-down state is entered if CE2 is LOW or CE2# is HIGH.
85	ADSC#	Input	Synchronous Address Status Controller: This active LOW input interrupts any ongoing burst and causes a new external address to be registered. A READ or WRITE is performed using the new address if all chip enables are active. Power-down state is entered if one or more chip enables are inactive.

PIN DESCRIPTIONS (continued)

TQFP PINS	SYMBOL	TYPE	DESCRIPTION
64	ZZ	Input	Snooze Enable: This active HIGH asynchronous input causes the device to enter a low-power standby mode in which all data in the memory array is retained. When active, all other inputs are ignored.
87	BWE#	Input	Byte Write Enable: This active LOW input permits byte write operations and must meet the setup and hold times around the rising edge of CLK.
88	GW#	Input	Global Write: This active LOW input allows a full 36-bit WRITE to occur independent of the BWE# and BWn# lines and must meet the setup and hold times around the rising edge of CLK.
16, 66	NC	-	No Connect: These signals are not internally connected. These signals may be connected to ground to improve package heat dissipation.
38, 39, 42, 43	DNU	-	Do Not Use: These signals may either be unconnected or wired to GND to improve package heat dissipation.
52, 53, 56, 57, 58, 59, 62, 63, 68, 69, 72, 73, 74, 75, 78, 79, 2, 3, 6, 7, 8, 9, 12, 13, 18, 19, 22, 23, 24, 25, 28, 29	DQ1-DQ32	Input/ Output	SRAM Data I/O: Byte 1 is DQ1-DQ8; Byte 2 is DQ9-DQ16; Byte 3 is DQ17-DQ24; Byte 4 is DQ25-DQ32. Input data must meet setup and hold times around the rising edge of CLK.
51, 80, 1, 30	NC/DQP1- NC/DQP4	NC/ I/O	No Connect/Parity Data I/O: On the x36 version, Byte 1 Parity is DQP1; Byte 2 Parity is DQP2; Byte 3 Parity is DQP3; Byte 4 Parity is DQP4. On the x32 version, these pins are No Connects (NC).
31	MODE	Input	Mode: This input selects the burst sequence. A LOW on this pin selects LINEAR BURST. NC or HIGH on this pin selects INTERLEAVED BURST. Do not alter input state while device is operating.
15, 41, 65, 91	Vcc	Supply	Power Supply: +3.3V +10%/-5%
4, 11, 20, 27, 54, 61, 70, 77	VccQ	Supply	Isolated Output Buffer Supply: +2.5V +0.4V/-0.125V.
5, 10, 14, 17, 21, 26, 40, 55, 60, 67, 71, 76, 90	Vss	Supply	Ground: GND. Pin 14 does not have to be connected directly to GND as long as the input voltage is $\leq V_{IL}$.

INTERLEAVED BURST ADDRESS TABLE (MODE = NC OR HIGH)

First Address (External)	Second Address (Internal)	Third Address (Internal)	Fourth Address (Internal)
X...X00	X...X01	X...X10	X...X11
X...X01	X...X00	X...X11	X...X10
X...X10	X...X11	X...X00	X...X01
X...X11	X...X10	X...X01	X...X00

LINEAR BURST ADDRESS TABLE (MODE = GND)

First Address (External)	Second Address (Internal)	Third Address (Internal)	Fourth Address (Internal)
X...X00	X...X01	X...X10	X...X11
X...X01	X...X10	X...X11	X...X00
X...X10	X...X11	X...X00	X...X01
X...X11	X...X00	X...X01	X...X10

PARTIAL TRUTH TABLE FOR WRITE COMMANDS

Function	GW#	BWE#	BW1#	BW2#	BW3#	BW4#
READ	H	H	X	X	X	X
READ	H	L	H	H	H	H
WRITE Byte 1	H	L	L	H	H	H
WRITE all bytes	H	L	L	L	L	L
WRITE all bytes	L	X	X	X	X	X

NOTE: Using BWE# and BW1# through BW4#, any one or more bytes may be written.

TRUTH TABLE

OPERATION	ADDRESS USED	CE#	CE2#	CE2	ZZ	ADSP#	ADSC#	ADV#	WRITE#	OE#	CLK	DQ
Deselected Cycle, Power-down	None	H	X	X	L	X	L	X	X	X	L-H	High-Z
Deselected Cycle, Power-down	None	L	X	L	L	L	X	X	X	X	L-H	High-Z
Deselected Cycle, Power-down	None	L	H	X	L	L	X	X	X	X	L-H	High-Z
Deselected Cycle, Power-down	None	L	X	L	L	H	L	X	X	X	L-H	High-Z
Deselected Cycle, Power-down	None	L	H	X	L	H	L	X	X	X	L-H	High-Z
SNOOZE MODE, Power-down	None	X	X	X	H	X	X	X	X	X	X	High-Z
READ Cycle, Begin Burst	External	L	L	H	L	L	X	X	X	L	L-H	Q
READ Cycle, Begin Burst	External	L	L	H	L	L	X	X	X	H	L-H	High-Z
WRITE Cycle, Begin Burst	External	L	L	H	L	H	L	X	L	X	L-H	D
READ Cycle, Begin Burst	External	L	L	H	L	H	L	X	H	L	L-H	Q
READ Cycle, Begin Burst	External	L	L	H	L	H	L	X	H	H	L-H	High-Z
READ Cycle, Continue Burst	Next	X	X	X	L	H	H	L	H	L	L-H	Q
READ Cycle, Continue Burst	Next	X	X	X	L	H	H	L	H	H	L-H	High-Z
READ Cycle, Continue Burst	Next	H	X	X	L	X	H	L	H	L	L-H	Q
READ Cycle, Continue Burst	Next	H	X	X	L	X	H	L	H	H	L-H	High-Z
WRITE Cycle, Continue Burst	Next	X	X	X	L	H	H	L	L	X	L-H	D
WRITE Cycle, Continue Burst	Next	H	X	X	L	X	H	L	L	X	L-H	D
READ Cycle, Suspend Burst	Current	X	X	X	L	H	H	H	H	L	L-H	Q
READ Cycle, Suspend Burst	Current	X	X	X	L	H	H	H	H	H	L-H	High-Z
READ Cycle, Suspend Burst	Current	H	X	X	L	X	H	H	H	L	L-H	Q
READ Cycle, Suspend Burst	Current	H	X	X	L	X	H	H	H	H	L-H	High-Z
WRITE Cycle, Suspend Burst	Current	X	X	X	L	H	H	H	L	X	L-H	D
WRITE Cycle, Suspend Burst	Current	H	X	X	L	X	H	H	L	X	L-H	D

- NOTE:**
1. X means "don't care." H means logic HIGH. L means logic LOW. WRITE#=L means any one or more byte write enable signals (BW1#, BW2#, BW3# or BW4#) and BWE# are LOW or GW# is LOW. WRITE#=H means all byte write enable signals and GW# are HIGH.
 2. BW1# enables WRITES to Byte 1 (DQ1-DQ8, DQP1). BW2# enables WRITES to Byte 2 (DQ9-DQ16, DQP2). BW3# enables WRITES to Byte 3 (DQ17-DQ24, DQP3). BW4# enables WRITES to Byte 4 (DQ25-DQ32, DQP4). DQP1-DQP4 are available on the x36 version only.
 3. All inputs except OE# and ZZ must meet setup and hold times around the rising edge (LOW to HIGH) of CLK.
 4. Wait states are inserted by suspending burst.
 5. For a WRITE operation following a READ operation, OE# must be HIGH before the input data setup time and held HIGH throughout the input data hold time.
 6. This device contains circuitry that will ensure the outputs will be in High-Z during power-up.
 7. ADSP# LOW always initiates an internal READ at the L-H edge of CLK. A WRITE is performed by setting one or more byte write enable signals and BWE# LOW or GW# LOW for the subsequent L-H edge of CLK. Refer to WRITE timing diagram for clarification.

ABSOLUTE MAXIMUM RATINGS*

Voltage on Vcc Supply Relative to Vss	-0.5V to +4.6V
Voltage on VccQ Supply Relative to Vss	-0.5V to +4.6V
V _{IN} (DQxx)	-0.5V to VccQ +0.5V
V _{IN} (inputs)	-0.5V to Vcc +0.5V
Storage Temperature (plastic)	-55°C to +150°C
Junction Temperature**	+150°C
Short Circuit Output Current	100mA

*Stresses greater than those listed under "Absolute Maximum Ratings" may cause permanent damage to the device. This is a stress rating only and functional operation of the device at these or any other conditions above those indicated in the operational sections of this specification is not implied. Exposure to absolute maximum rating conditions for extended periods may affect reliability.

**Maximum junction temperature depends upon package type, cycle time, loading, ambient temperature and airflow. See Micron Technical Note TN-05-14 for more information.

ELECTRICAL CHARACTERISTICS AND RECOMMENDED DC OPERATING CONDITIONS

(0°C ≤ T_A ≤ 70°C; Vcc = +3.3V +0.3V/-0.165V; VccQ = +2.5V +0.4V/-0.125V unless otherwise noted)

DESCRIPTION	CONDITIONS	SYMBOL	MIN	MAX	UNITS	NOTES
Input High (Logic 1) Voltage	Databus (DQxx)	V _{IHQ}	1.7	VccQ+0.3	V	1, 2
	Inputs	V _{IH}	1.7	Vcc+0.3	V	1, 2
Input Low (Logic 0) Voltage		V _{IL}	-0.3	0.7	V	1, 2
Input Leakage Current	0V ≤ V _{IN} ≤ Vcc	I _{LI}	-1	1	μA	13
Output Leakage Current	Output(s) disabled, 0V ≤ V _{IN} ≤ VccQ (DQxx)	I _{LO}	-1	1	μA	
Output High Voltage	I _{OH} = -2.0mA	V _{OH}	1.7		V	1
	I _{OH} = -1.0mA	V _{OH}	2.0		V	1
Output Low Voltage	I _{OL} = 2.0mA	V _{OL}		0.7	V	1
	I _{OL} = 1.0mA	V _{OL}		0.4	V	1
Supply Voltage		Vcc	3.135	3.6	V	1
Isolated Output Buffer Supply		VccQ	2.375	2.9	V	1

ELECTRICAL CHARACTERISTICS AND RECOMMENDED DC OPERATING CONDITIONS
 $(0^{\circ}\text{C} \leq T_A \leq 70^{\circ}\text{C}; V_{CC} = +3.3\text{V} +0.3\text{V}/-0.165\text{V}; V_{CCQ} = +2.5\text{V} +0.4\text{V}/-0.125\text{V}$ unless otherwise noted)

DESCRIPTION	CONDITIONS	SYM	TYP	MAX					UNITS	NOTES
				-8.5	-9	-10	-11	-12		
Power Supply Current: Operating	Device selected; all inputs $\leq V_{IL}$ or $\geq V_{IH}$; cycle time $\geq 1\text{KC MIN}$; $V_{CCQ} = \text{MAX}$; $V_{CC} = \text{MAX}$; outputs open	I _{CC}	TBD	250	230	200	200	150	mA	3, 11, 12
Power Supply Current: Idle	Device selected; $V_{CC} = \text{MAX}$; $V_{CCQ} = \text{MAX}$; ADSC#, ADSP#, ADV#, GW#, BW# $\geq V_{IH}$; inputs $\leq V_{SS} + 0.2$ or $\geq V_{CC} - 0.2$; Data (DQxx) $\leq V_{SS} + 0.2$ or $\geq V_{CCQ} - 0.2$; cycle time $\geq 1\text{KC MIN}$; outputs open	I _{CC1}	TBD	75	75	70	60	45	mA	11, 12
CMOS Standby	Device deselected; $V_{CC} = \text{MAX}$; $V_{CCQ} = \text{MAX}$; inputs $\leq V_{SS} + 0.2$ or $\geq V_{CC} - 0.2$; Data (DQxx) $\leq V_{SS} + 0.2$ or $\geq V_{CCQ} - 0.2$; all inputs static; CLK frequency = 0	I _{SB2}	TBD	5	5	5	5	5	mA	11, 12
TTL Standby	Device deselected; $V_{CC} = \text{MAX}$; $V_{CCQ} = \text{MAX}$; all inputs $\leq V_{IL}$ or $\geq V_{IH}$; all inputs static; CLK frequency = 0	I _{SB3}	TBD	25	25	25	25	25	mA	11, 12
Clock Running	Device deselected; $V_{CC} = \text{MAX}$; $V_{CCQ} = \text{MAX}$; inputs $\leq V_{SS} + 0.2$ or $\geq V_{CC} - 0.2$; Data (DQxx) $\leq V_{SS} + 0.2$ or $\geq V_{CCQ} - 0.2$; cycle time $\geq 1\text{KC MIN}$	I _{SB4}	TBD	75	75	70	60	45	mA	11, 12

CAPACITANCE

DESCRIPTION	CONDITIONS	SYMBOL	TYP	MAX	UNITS	NOTES
Control Input Capacitance	$T_A = 25^{\circ}\text{C}; f = 1\text{ MHz}$ $V_{CCQ} = 2.5\text{V}$	C _I	3	4	pF	1
Input/Output Capacitance (DQ)		C _O	6	8	pF	1
Address and Clock Input Capacitance		C _A	2.5	3	pF	1

THERMAL CONSIDERATIONS

DESCRIPTION	CONDITIONS	SYMBOL	TYP	UNITS	NOTES
Thermal resistance - Junction to Ambient	Still Air, soldered on 4.25 x	θ_{JA}	TBD	$^{\circ}\text{C/W}$	1
Thermal resistance - Junction to Case	1.125 inch 4-layer circuit board	θ_{JC}	TBD	$^{\circ}\text{C/W}$	1

NOTE: 1. This parameter is sampled.

ELECTRICAL CHARACTERISTICS AND RECOMMENDED AC OPERATING CONDITIONS

 (Note 5) $0^{\circ}\text{C} \leq T_A \leq 70^{\circ}\text{C}$; $V_{CC} = +3.3\text{V} +0.3\text{V}/-0.165\text{V}$; $V_{CCQ} = +2.5\text{V} +0.4\text{V}/-0.125\text{V}$

DESCRIPTION	SYM	-8.5		-9		-10		-11		-12		UNITS	NOTES
		MIN	MAX	MIN	MAX	MIN	MAX	MIN	MAX	MIN	MAX		
Clock													
Clock cycle time	t_{KC}	12		13		15		15		20		ns	
Clock HIGH time	t_{KH}	4		4		5		5		6		ns	
Clock LOW time	t_{KL}	4		4		5		5		6		ns	
Output Times													
Clock to output valid	t_{KQ}		8.5		9		10		11		12	ns	
Clock to output invalid	t_{KQX}	3		3		3		3		3		ns	
Clock to output in Low-Z	t_{KQLZ}	4		4		4		4		4		ns	4, 6, 7
Clock to output in High-Z	t_{KQHZ}		5		5		5		5		6	ns	4, 6, 7
OE# to output valid	t_{OEQ}		5		5		5		5		6	ns	9
OE# to output in Low-Z	t_{OELZ}	0		0		0		0		0		ns	4, 6, 7
OE# to output in High-Z	t_{OEHZ}		5		5		5		5		6	ns	4, 6, 7
Setup Times													
Address	t_{AS}	2.5		2.5		2.5		2.5		3		ns	8, 10
Address Status (ADSC#, ADSP#)	t_{ADSS}	2.5		2.5		2.5		2.5		3		ns	8, 10
Address Advance (ADV#)	t_{AAS}	2.5		2.5		2.5		2.5		3		ns	8, 10
Byte Write Enables (BW1#, BW2#, BW3#, BW4#, BWE#, GW#)	t_{WS}	2.5		2.5		2.5		2.5		3		ns	8, 10
Data-in	t_{DS}	2.5		2.5		2.5		2.5		3		ns	8, 10
Chip Enable (CE#, CE2#, CE2)	t_{CES}	2.5		2.5		2.5		2.5		3		ns	8, 10
Hold Times													
Address	t_{AH}	0.5		0.5		0.5		0.5		0.5		ns	8, 10
Address Status (ADSC#, ADSP#)	t_{ADSH}	0.5		0.5		0.5		0.5		0.5		ns	8, 10
Address Advance (ADV#)	t_{AAH}	0.5		0.5		0.5		0.5		0.5		ns	8, 10
Byte Write Enables (BW1#, BW2#, BW3#, BW4#, BWE#, GW#)	t_{WH}	0.5		0.5		0.5		0.5		0.5		ns	8, 10
Data-in	t_{DH}	0.5		0.5		0.5		0.5		0.5		ns	8, 10
Chip Enable (CE#, CE2#, CE2)	t_{CEH}	0.5		0.5		0.5		0.5		0.5		ns	8, 10

NEW SYNCBURST FLOW-THROUGH - 2.5V I/O

AC TEST CONDITIONS

Input pulse levels	V _{SS} to 2.5V
Input rise and fall times	2.5ns
Input timing reference levels	1.25V
Output reference levels	1.25V
Output load	See Figures 1 and 2

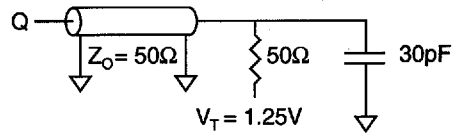

Fig. 1 OUTPUT LOAD EQUIVALENT

NOTES

- All voltages referenced to V_{SS} (GND).
- Overshoot: V_{IH} ≤ +4.6V for t ≤ 1/2 t_{CK} for I ≤ 20mA
Undershoot: V_{IL} ≥ -0.7V for t ≤ 1/2 t_{CK} for I ≤ 20mA
Power-up: V_{IH} ≤ +3.6V, V_{CC} ≤ 3.135V
and V_{CCQ} ≤ 2.375V for t ≤ 200ms
- I_{CC} is given with no output current. I_{CC} increases with faster cycle times.
- This parameter is sampled.
- Test conditions as specified with the output loading as shown in Fig. 1 unless otherwise noted.
- Output loading is specified using Fig. 1 with C_L = 5pF versus 30pF. Transition is measured ±150mV from steady state voltage.
- At any given temperature and voltage condition, t_{KQHZ} is less than t_{KQLZ}.
- A WRITE cycle is defined by at least one byte write enable LOW and ADSP# HIGH for the required setup and hold times. A READ cycle is defined by all byte write enables HIGH and (ADSC# or ADV# LOW) or ADSP# LOW for the required setup and hold times.
- OE# is a "don't care" when a byte write enable is sampled LOW.
- This is a synchronous device. All addresses must meet the specified setup and hold times for all rising edges of CLK when either ADSP# or ADSC# is LOW and chip enabled. All other synchronous inputs must meet the setup and hold times with stable logic levels for all rising edges of clock (CLK) when the chip is enabled. Chip enable must be valid at each rising edge of CLK (when either ADSP# or ADSC# is LOW) to remain enabled.
- "Device Deselected" means device is in POWER-DOWN mode as defined in the Truth Table. "Device Selected" means device is active (not in POWER-DOWN mode).
- Typical values are measured at V_{CC} = 3.3V, V_{CCQ} = 2.5V, 25°C, and 15ns cycle time.
- MODE pin has an internal pull-up and exhibits an input leakage current of ±10μA.

LOAD DERATING CURVES

Micron 128K x 32 and 128K x 36 Synchronous SRAM timing is dependent upon the capacitive loading on the outputs. The data sheet is written assuming a load of 30pF.

Consult the factory for copies of I/O current versus voltage curves. For capacitive loading derating curves see Micron Technical Note TN-05-20, "3.3V SRAM Capacitive Loading."

SNOOZE MODE

SNOOZE MODE is a low current, "power-down" mode in which the device is deselected and current is reduced to I_{SB2} . The duration of SNOOZE MODE is dictated by the length of time the ZZ pin is in a HIGH state. After entering SNOOZE MODE, all inputs except ZZ become gated inputs and are ignored.

The ZZ pin (pin 64) is an asynchronous, active HIGH input that causes the device to enter SNOOZE MODE. When the ZZ pin becomes a logic HIGH, I_{SB2} is guaranteed after the setup time t_{ZZ} is met. Any access pending when entering SNOOZE MODE is not guaranteed to successfully complete. Therefore, SNOOZE MODE must not be initiated until valid pending operations are completed.

SNOOZE MODE ELECTRICAL CHARACTERISTICS

DESCRIPTION	CONDITIONS	SYMBOL	MIN	MAX	UNITS	NOTES
Current during SNOOZE MODE	$ZZ \geq V_{IH}$	I_{SB2Z}		5	mA	
ZZ HIGH to SNOOZE MODE time		t_{ZZ}	t_{KC}		ns	1
SNOOZE MODE Operation recovery time		t_{RZZ}		t_{KC}	ns	1

NOTE: 1. This parameter is sampled.

SNOOZE MODE WAVEFORM

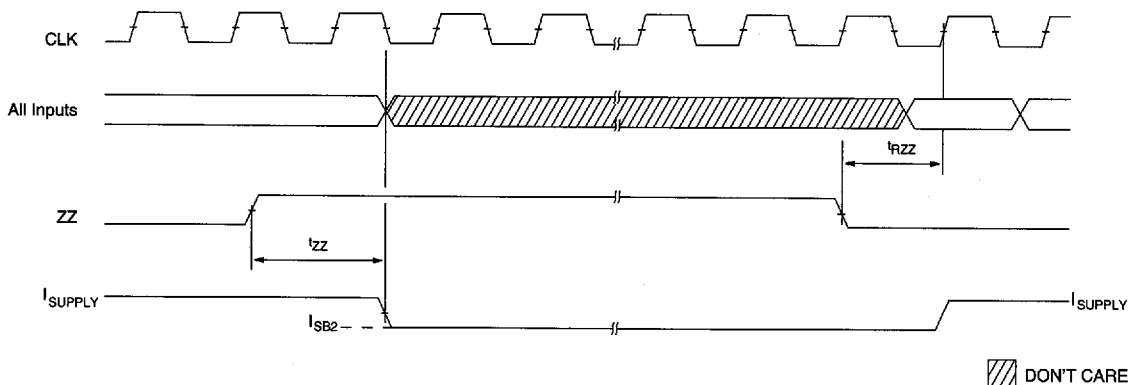

READ TIMING

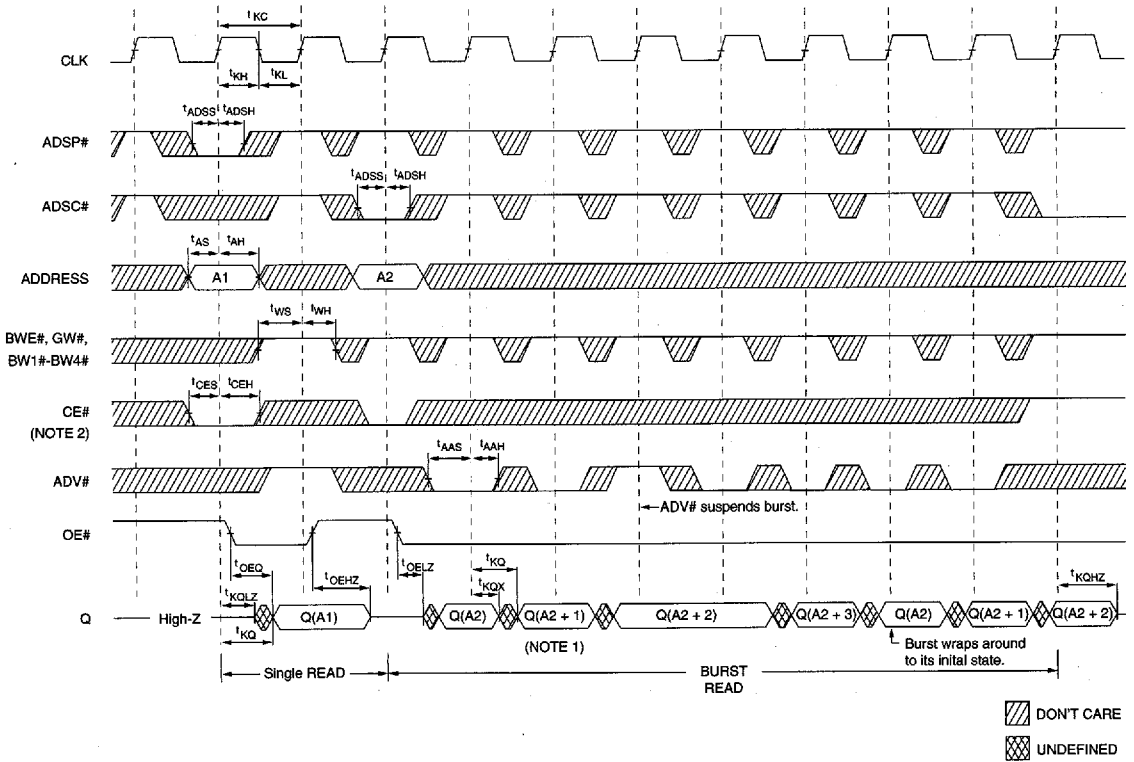

▨ DONT CARE
▩ UNDEFINED

- NOTE:**
1. Q(A2) refers to output from address A2. Q(A2+1) refers to output from the next internal burst address following A2.
 2. CE2# and CE2 have timing identical to CE#. On this diagram, when CE# is LOW, CE2# is LOW and CE2 is HIGH. When CE# is HIGH, CE2# is HIGH and CE2 is LOW.
 3. Timing is shown assuming that the device was not enabled before entering into this sequence. OE# does not cause Q to be driven until after the following clock rising edge.

READ TIMING PARAMETERS

	-8.5		-9		-10		-11		-12		
SYM	MIN	MAX	MIN	MAX	MIN	MAX	MIN	MAX	MIN	MAX	UNITS
t_{KC}	12		13		15		15		20		ns
t_{KH}	4		4		5		5		6		ns
t_{KL}	4		4		5		5		6		ns
t_{KQ}		8.5		9		10		11		12	ns
t_{KQX}	3		3		3		3		3		ns
t_{KQZ}	4		4		4		4		4		ns
t_{KQHZ}		5		5		5		5		6	ns
t_{OEQ}		5		5		5		5		6	ns
t_{OELZ}	0		0		0		0		0		ns
t_{OEZH}		5		5		5		5		6	ns

	-8.5		-9		-10		-11		-12		
SYM	MIN	MAX	MIN	MAX	MIN	MAX	MIN	MAX	MIN	MAX	UNITS
t_{AS}	2.5		2.5		2.5		2.5		3		ns
t_{ADSS}	2.5		2.5		2.5		2.5		3		ns
t_{AAS}	2.5		2.5		2.5		2.5		3		ns
t_{WS}	2.5		2.5		2.5		2.5		3		ns
t_{CES}	2.5		2.5		2.5		2.5		3		ns
t_{AH}	0.5		0.5		0.5		0.5		0.5		ns
t_{ADSH}	0.5		0.5		0.5		0.5		0.5		ns
t_{AAH}	0.5		0.5		0.5		0.5		0.5		ns
t_{WH}	0.5		0.5		0.5		0.5		0.5		ns
t_{CEH}	0.5		0.5		0.5		0.5		0.5		ns

NEW SYNCBURST FLOW-THROUGH - 2.5V I/O

WRITE TIMING

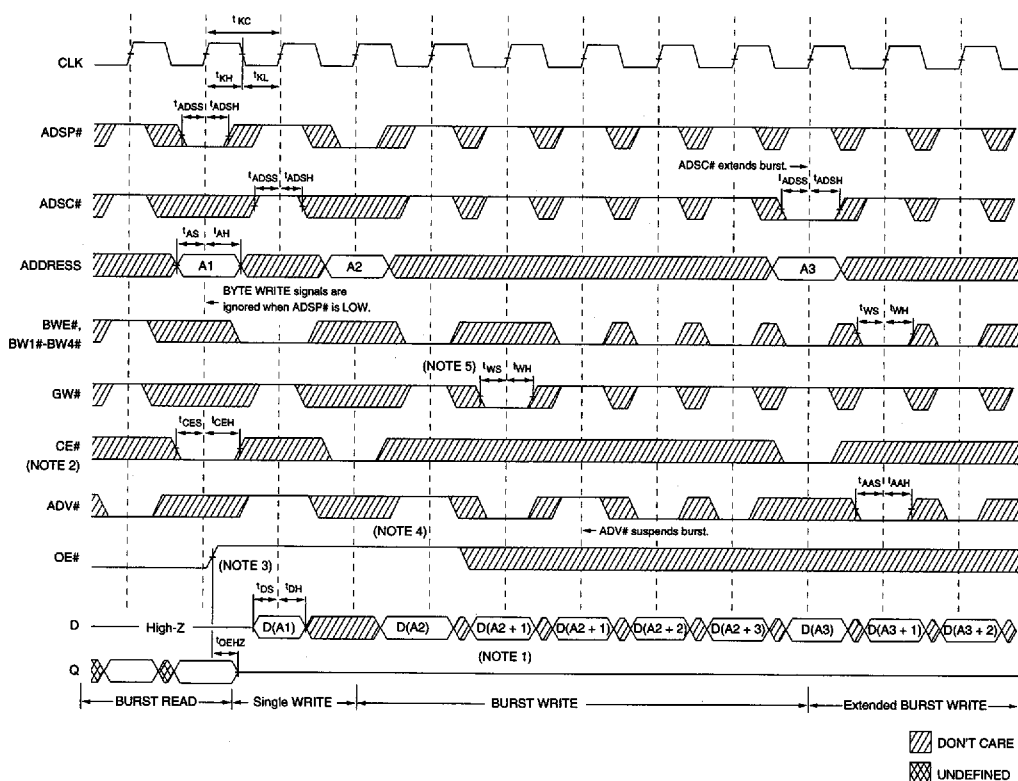

- NOTE:
1. D(A2) refers to input for address A2. D(A2+1) refers to input for the next internal burst address following A2.
 2. CE2# and CE2 have timing identical to CE#. On this diagram, when CE# is LOW, CE2# is LOW and CE2 is HIGH. When CE# is HIGH, CE2# is HIGH and CE2 is LOW.
 3. OE# must be HIGH before the input data setup and held HIGH throughout the data hold time. This prevents input/output data contention for the time period prior to the byte write enable inputs being sampled.
 4. ADV# must be HIGH to permit a WRITE to the loaded address.
 5. Full width WRITE can be initiated by GW# LOW or GW# HIGH and BWE#, BW1#- BW4# LOW.

WRITE TIMING PARAMETERS

SYM	-8.5		-9		-10		-11		-12		UNITS
	MIN	MAX	MIN	MAX	MIN	MAX	MIN	MAX	MIN	MAX	
t _{KC}	12		13		15		15		20		ns
t _{KH}	4		4		5		5		6		ns
t _{KL}	4		4		5		5		6		ns
t _{OEHZ}		5		5		5		5		6	ns
t _{AS}	2.5	2.5		2.5		2.5		3			ns
t _{ADSS}	2.5	2.5		2.5		2.5		3			ns
t _{AAS}	2.5	2.5		2.5		2.5		3			ns
t _{WS}	2.5	2.5		2.5		2.5		3			ns

SYM	-8.5		-9		-10		-11		-12		UNITS
	MIN	MAX	MIN	MAX	MIN	MAX	MIN	MAX	MIN	MAX	
t _{DS}	2.5		2.5		2.5		2.5		3		ns
t _{CES}	2.5		2.5		2.5		2.5		3		ns
t _{AH}	0.5		0.5		0.5		0.5		0.5		ns
t _{ADSH}	0.5		0.5		0.5		0.5		0.5		ns
t _{AAH}	0.5		0.5		0.5		0.5		0.5		ns
t _{WH}	0.5		0.5		0.5		0.5		0.5		ns
t _{DH}	0.5		0.5		0.5		0.5		0.5		ns
t _{CEH}	0.5		0.5		0.5		0.5		0.5		ns

READ/WRITE TIMING

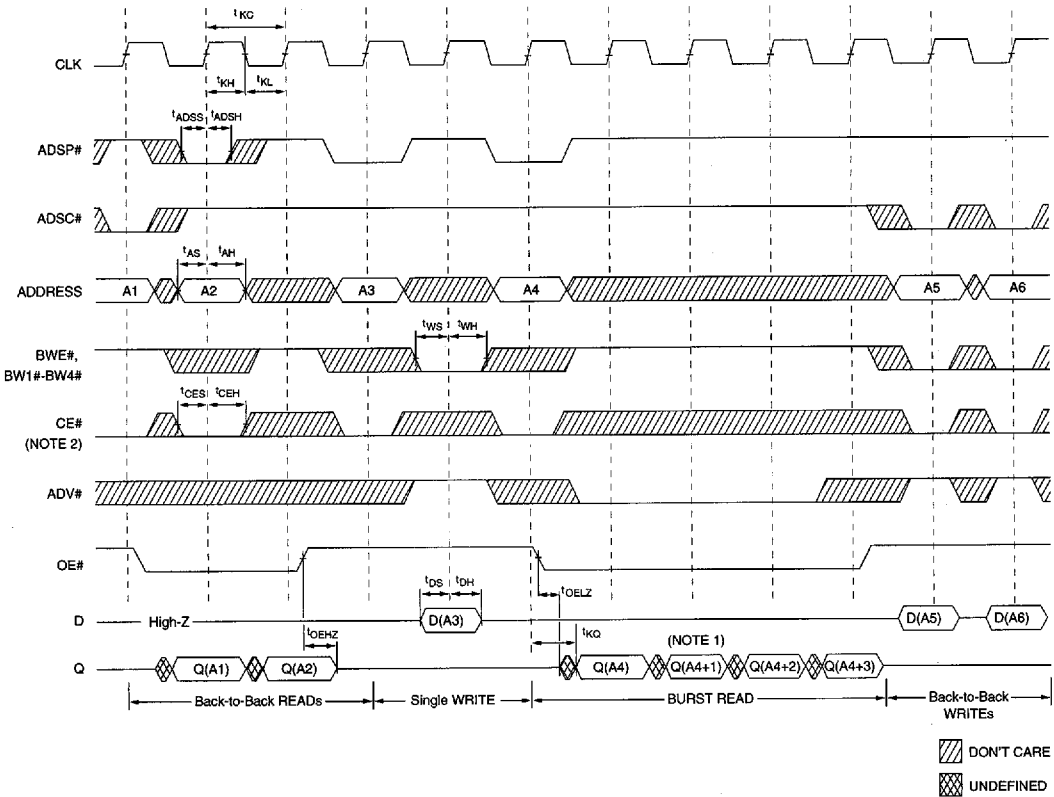

- NOTE:**
1. Q(A4) refers to output from address A4. Q(A4+1) refers to output from the next internal burst address following A4.
 2. CE2# and CE2 have timing identical to CE#. On this diagram, when CE# is LOW, CE2# is LOW and CE2 is HIGH. When CE# is HIGH, CE2# is HIGH and CE2 is LOW.
 3. The data bus (Q) remains in High-Z following a WRITE cycle unless an ADSP#, ADSC# or ADV# cycle is performed.
 4. GW# is HIGH.
 5. Back-to-back READs may be controlled by either ADSP# or ADSC#.

READ/WRITE TIMING PARAMETERS

	-8.5		-9		-10		-11		-12		
SYM	MIN	MAX	MIN	MAX	MIN	MAX	MIN	MAX	MIN	MAX	UNITS
t _{KC}	12		13		15		15		20		ns
t _{KH}	4		4		5		5		6		ns
t _{KL}	4		4		5		5		6		ns
t _{KQ}		8.5		9		10		11		12	ns
t _{OEZL}	0		0		0		0		0		ns
t _{OEZH}		5		5		5		5		6	ns
t _{AS}	2.5		2.5		2.5		2.5		3		ns
t _{ADSS}	2.5		2.5		2.5		2.5		3		ns

	-8.5		-9		-10		-11		-12		
SYM	MIN	MAX	MIN	MAX	MIN	MAX	MIN	MAX	MIN	MAX	UNITS
t _{WS}	2.5		2.5		2.5		2.5		3		ns
t _{DS}	2.5		2.5		2.5		2.5		3		ns
t _{CEH}	2.5		2.5		2.5		2.5		3		ns
t _{AH}	0.5		0.5		0.5		0.5		0.5		ns
t _{ADSH}	0.5		0.5		0.5		0.5		0.5		ns
t _{WH}	0.5		0.5		0.5		0.5		0.5		ns
t _{DH}	0.5		0.5		0.5		0.5		0.5		ns
t _{CEH}	0.5		0.5		0.5		0.5		0.5		ns

PACKAGE SELECTION GUIDE

PACKAGE TYPE	REFERENCE CODE	PIN COUNT	WIDTH	PAGE
TQFP				
	SA	100	14.0 mm x 20.0 mm	7-1

PACKAGE TYPE	REFERENCE CODE	PIN COUNT	HEIGHT	PAGE
MODULE DIMM				
	SB	160	1.150"	7-2

100-PIN TQFP
SA-1

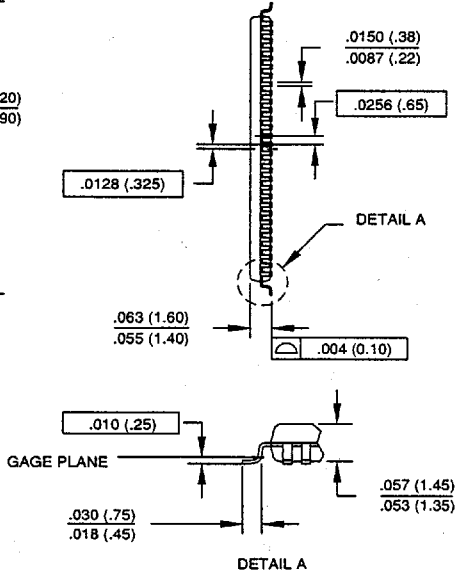
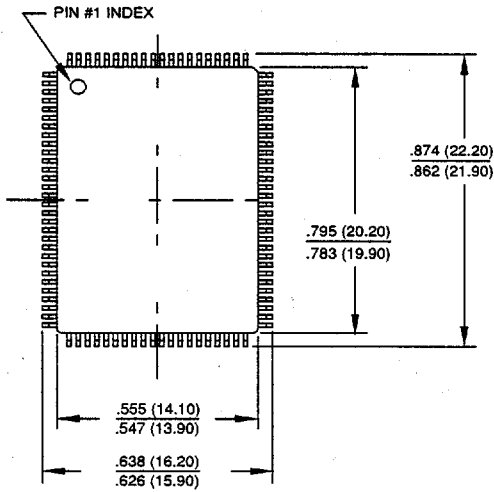

- NOTE:**
1. All dimensions in inches (millimeters) $\frac{\text{MAX}}{\text{MIN}}$ or typical where noted.
 2. Package width and length do not include mold protrusion; allowable mold protrusion is .01" per side.

**160-PIN MODULE DIMM
SB-1**

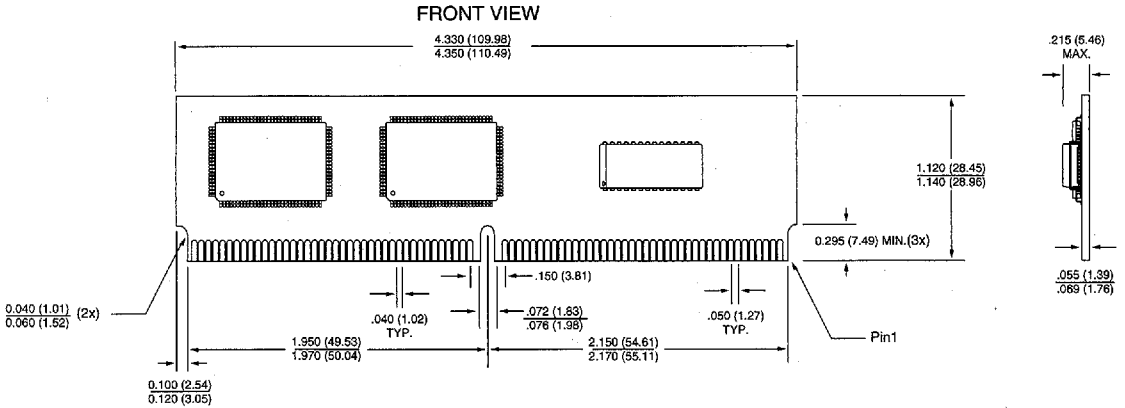

**160-PIN MODULE DIMM
SB-2**

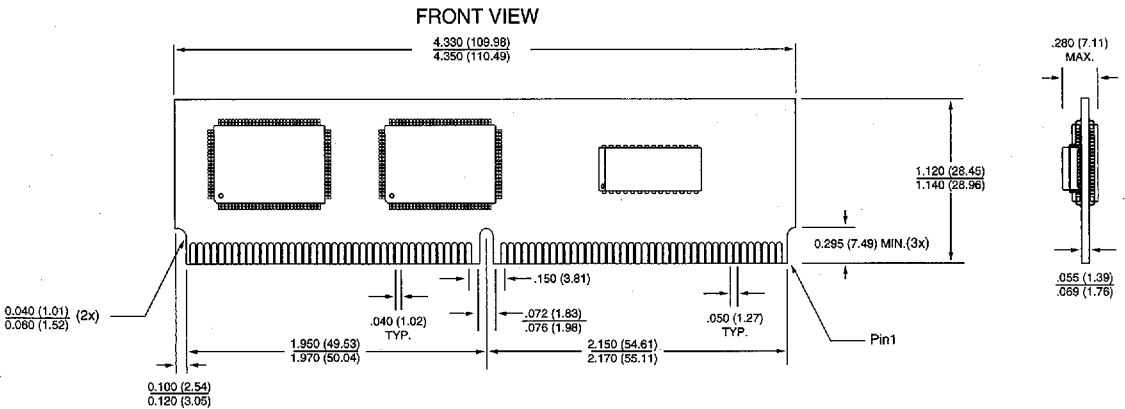

NOTE: 1. All dimensions in inches (millimeters) $\frac{\text{MAX}}{\text{MIN}}$ or typical where noted.

PACKAGE INFORMATION

100-PIN TQFP
SA-1

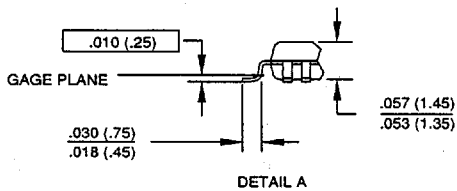
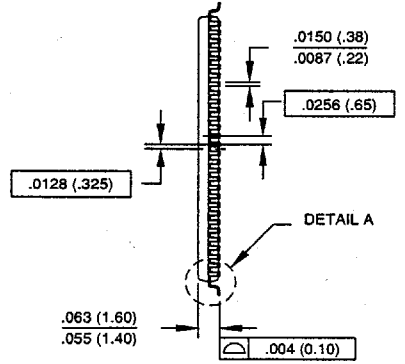
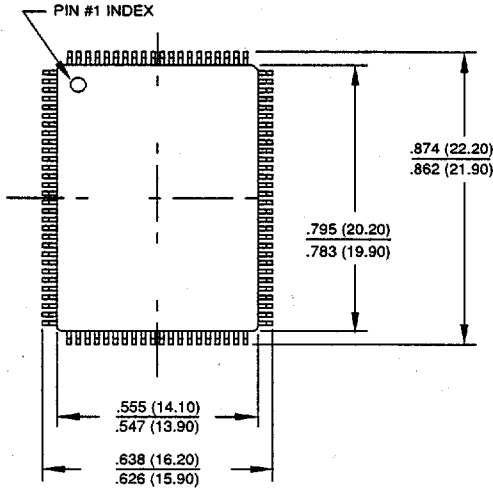

PACKAGE INFORMATION

- NOTE:**
1. All dimensions in inches (millimeters) $\frac{\text{MAX}}{\text{MIN}}$ or typical where noted.
 2. Package width and length do not include mold protrusion; allowable mold protrusion is .01" per side.

**160-PIN MODULE DIMM
SB-1**

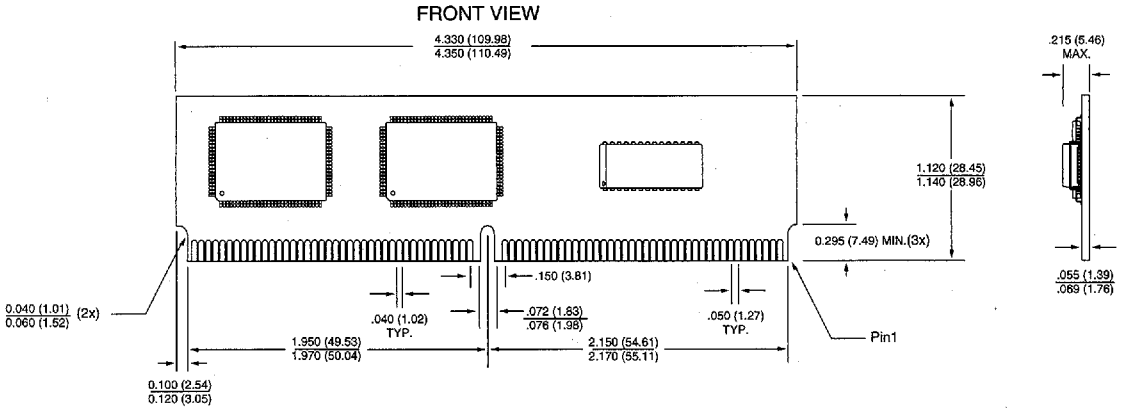

**160-PIN MODULE DIMM
SB-2**

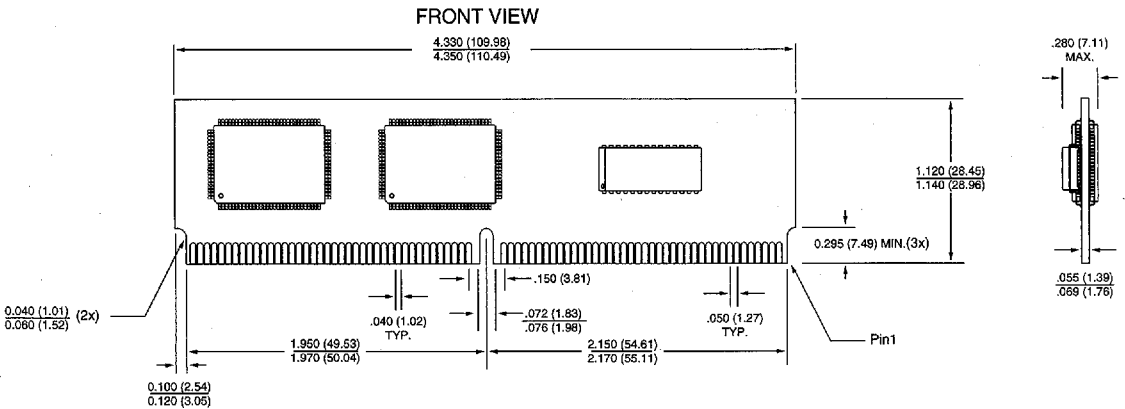

NOTE: 1. All dimensions in inches (millimeters) $\frac{\text{MAX}}{\text{MIN}}$ or typical where noted.

PACKAGE INFORMATION