

**2SC5414**

## High-Frequency Low-Noise Amplifier Applications

### Features

- High gain :  $|S_{21e}|^2=9.5\text{dB typ (f=1GHz)}$ .
- High cutoff frequency :  $f_T=6.7\text{GHz typ}$ .

### Package Dimensions

unit:mm

2004B

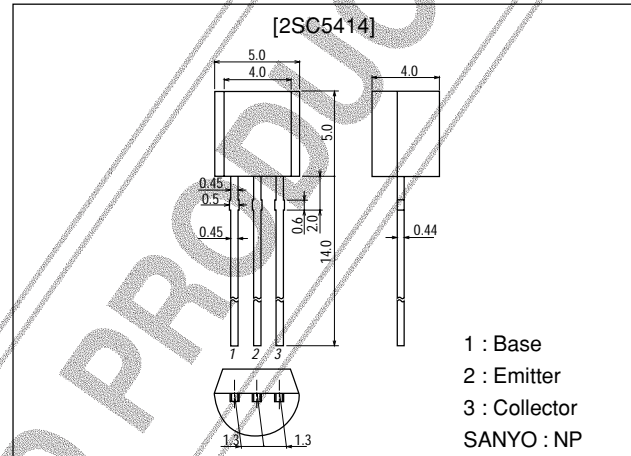

### Specifications

#### Absolute Maximum Ratings at $T_a = 25^\circ\text{C}$

Parameter	Symbol	Conditions	Ratings	Unit
Collector-to-Base Voltage	$V_{CB0}$		20	V
Collector-to-Emitter Voltage	$V_{CE0}$		12	V
Emitter-to-Base Voltage	$V_{EB0}$		2	V
Collector Current	$I_C$		100	mA
Collector Dissipation	$P_C$		400	mW
Junction Temperature	$T_J$		150	$^\circ\text{C}$
Storage Temperature	$T_{stg}$		-55 to +150	$^\circ\text{C}$

#### Electrical Characteristics at $T_a = 25^\circ\text{C}$

Parameter	Symbol	Conditions	Ratings			Unit
			min	typ	max	
Collector Cutoff Current	$I_{CB0}$	$V_{CB}=10\text{V}, I_E=0$			1.0	$\mu\text{A}$
Emitter Cutoff Current	$I_{EB0}$	$V_{EB}=1\text{V}, I_C=0$			10	$\mu\text{A}$
DC Current Gain	$h_{FE1}$	$V_{CE}=5\text{V}, I_C=30\text{mA}$	90*		270*	
	$h_{FE2}$	$V_{CE}=5\text{V}, I_C=70\text{mA}$	70			
Gain-Bandwidth Product	$f_T$	$V_{CE}=5\text{V}, I_C=30\text{mA}$	5	6.7		GHz
Output Capacitance	$C_{ob}$	$V_{CB}=5\text{V}, f=1\text{MHz}$		1.0	1.5	pF
Reverse Transfer Capacitance	$C_{re}$	$V_{CB}=5\text{V}, f=1\text{MHz}$		0.6		pF
Forward Transfer Gain	$ S_{21e} ^2$	$V_{CE}=5\text{V}, I_C=30\text{mA}, f=1\text{GHz}$	8	9.5		dB
Noise Figure	NF	$V_{CE}=5\text{V}, I_C=7\text{mA}, f=1\text{GHz}$		1.1	2.0	dB

\* The 2SC5414 is classified by 30mA  $h_{FE}$  as follows :

90	E	180	135	F	270
----	---	-----	-----	---	-----

■ Any and all SANYO products described or contained herein do not have specifications that can handle applications that require extremely high levels of reliability, such as life-support systems, aircraft's control systems, or other applications whose failure can be reasonably expected to result in serious physical and/or material damage. Consult with your SANYO representative nearest you before using any SANYO products described or contained herein in such applications.

■ SANYO assumes no responsibility for equipment failures that result from using products at values that exceed, even momentarily, rated values (such as maximum ratings, operating condition ranges, or other parameters) listed in products specifications of any and all SANYO products described or contained herein.

**SANYO Electric Co., Ltd. Semiconductor Company**

TOKYO OFFICE Tokyo Bldg., 1-10, 1 Chome, Ueno, Taito-ku, TOKYO, 110-8534 JAPAN

# 2SC5414

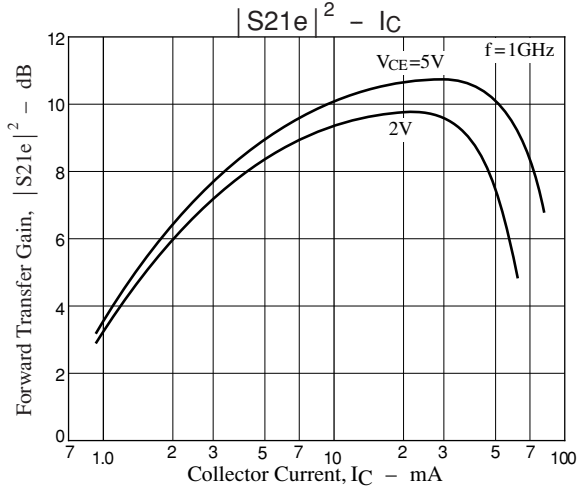
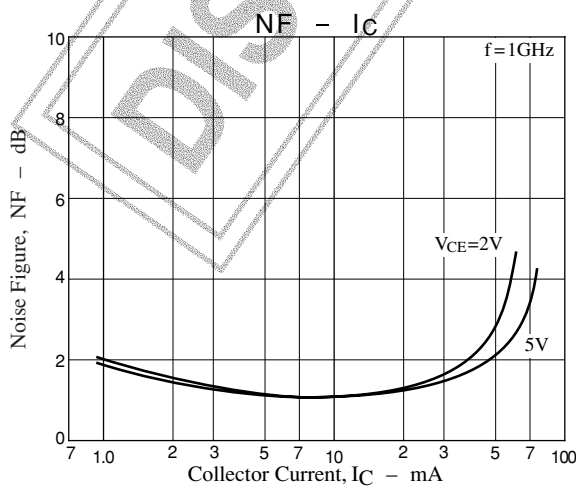
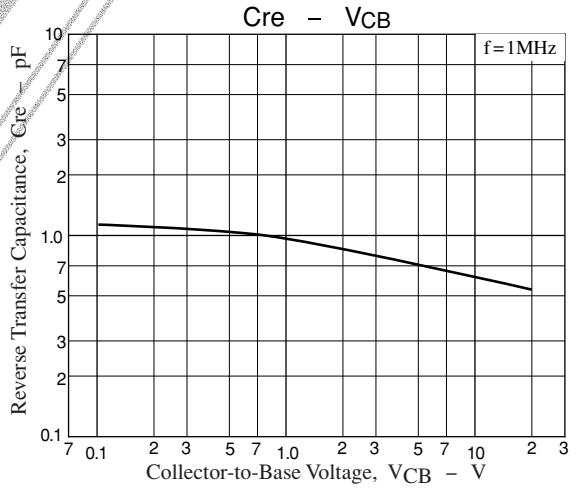
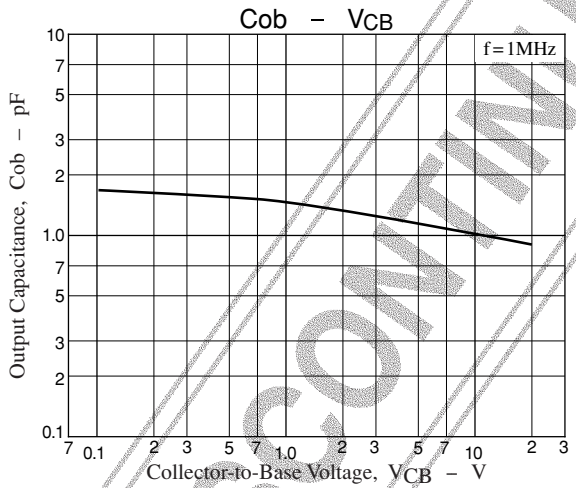
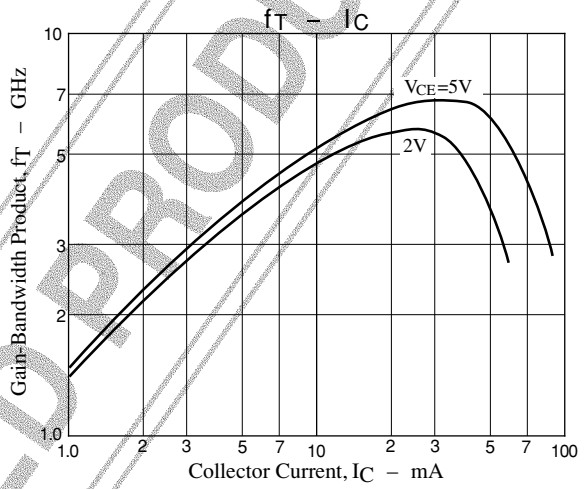
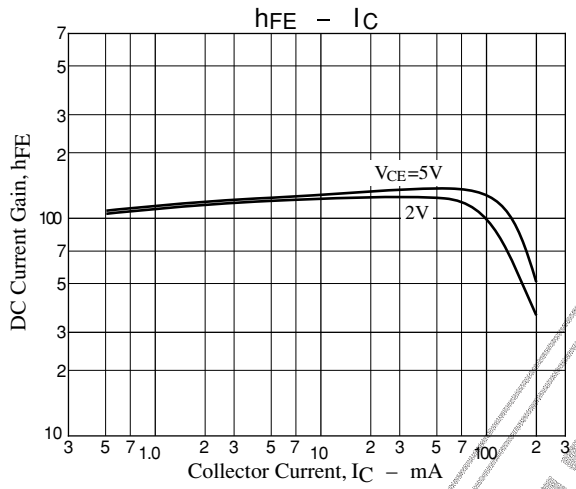
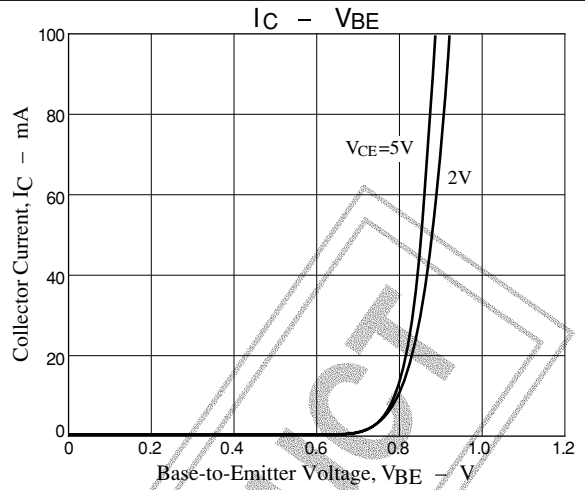
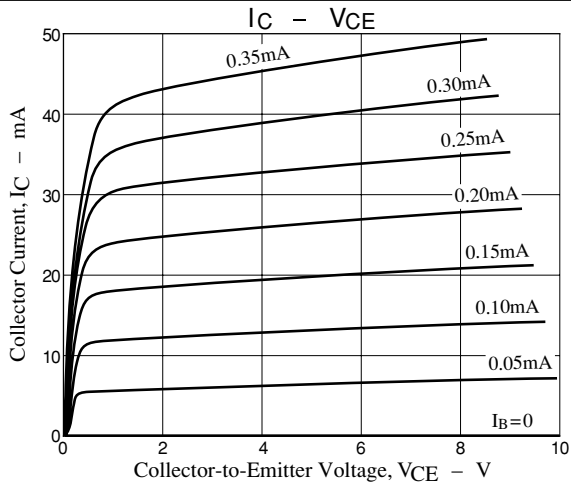

## 2SC5414

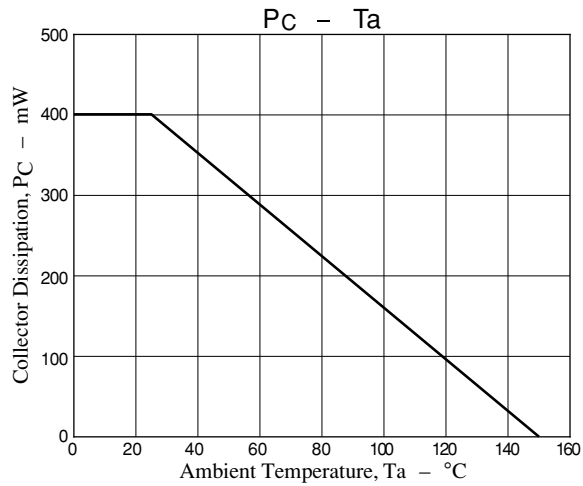

### S Parameters (Common emitter)

V<sub>CE</sub>=2V, I<sub>C</sub>=5mA, Z<sub>O</sub>=50Ω

Freq (MHz)	S <sub>11</sub>	∠ S <sub>11</sub>	S <sub>21</sub>	∠ S <sub>21</sub>	S <sub>12</sub>	∠ S <sub>12</sub>	S <sub>22</sub>	∠ S <sub>22</sub>
100	0.789	-46.1	12.790	142.7	0.041	66.1	0.870	-25.4
200	0.604	-80.1	9.631	117.8	0.063	53.1	0.691	-39.5
400	0.404	-123.7	5.802	90.2	0.090	44.6	0.510	-51.7
600	0.331	-153.8	4.101	72.4	0.112	42.2	0.444	-58.8
800	0.297	-177.9	3.180	58.0	0.137	39.3	0.419	-66.4
1000	0.281	160.9	2.642	45.5	0.163	35.7	0.413	-74.1
1200	0.275	140.4	2.254	32.7	0.190	31.0	0.410	-82.5
1400	0.277	122.6	1.983	21.5	0.218	26.0	0.405	-90.9
1600	0.281	103.9	1.787	10.3	0.247	20.5	0.395	-99.8
1800	0.295	89.0	1.626	-0.1	0.278	14.4	0.390	-108.3
2000	0.314	73.5	1.511	-10.3	0.311	7.7	0.380	-117.5

V<sub>CE</sub>=2V, I<sub>C</sub>=10mA, Z<sub>O</sub>=50Ω

Freq (MHz)	S <sub>11</sub>	∠ S <sub>11</sub>	S <sub>21</sub>	∠ S <sub>21</sub>	S <sub>12</sub>	∠ S <sub>12</sub>	S <sub>22</sub>	∠ S <sub>22</sub>
100	0.638	-60.1	18.641	131.8	0.036	63.1	0.754	-33.9
200	0.438	-95.8	12.165	107.7	0.054	55.5	0.549	-45.7
400	0.289	-138.8	6.728	84.2	0.083	53.2	0.392	-53.9
600	0.245	-168.0	4.654	69.1	0.113	50.5	0.348	-59.7
800	0.227	170.3	3.575	56.2	0.146	45.7	0.336	-67.3
1000	0.221	150.3	2.950	44.5	0.177	40.1	0.335	-75.3
1200	0.215	130.3	2.520	32.5	0.221	30.9	0.332	-86.7
1400	0.218	113.3	2.203	21.6	0.240	27.0	0.331	-92.3
1600	0.231	96.2	1.978	11.2	0.272	20.1	0.320	-101.1
1800	0.243	80.8	1.805	1.2	0.304	13.0	0.314	-109.7
2000	0.267	66.9	1.668	-8.9	0.336	5.5	0.306	-118.6

## 2SC5414

$V_{CE}=2V, I_C=20mA, Z_O=50\Omega$

Freq (MHz)	$ S_{11} $	$\angle S_{11}$	$ S_{21} $	$\angle S_{21}$	$ S_{12} $	$\angle S_{12}$	$ S_{22} $	$\angle S_{22}$
100	0.476	-75.8	22.939	121.7	0.031	62.9	0.633	-40.4
200	0.317	-113.1	13.544	100.3	0.047	61.2	0.427	-48.3
400	0.227	-155.0	7.193	80.3	0.081	59.5	0.319	-53.3
600	0.206	178.6	4.913	66.5	0.116	55.1	0.293	-59.0
800	0.195	158.2	3.764	54.3	0.151	49.1	0.289	-67.1
1000	0.194	139.7	3.091	43.4	0.186	42.4	0.291	-75.4
1200	0.198	121.4	2.632	32.0	0.220	34.9	0.294	-84.4
1400	0.204	105.8	2.305	21.3	0.253	27.5	0.290	-93.3
1600	0.213	89.2	2.066	11.2	0.285	20.1	0.281	-102.3
1800	0.230	75.2	1.881	1.5	0.318	12.5	0.275	-111.0
2000	0.252	62.9	1.742	-8.4	0.350	4.6	0.264	-120.0

$V_{CE}=2V, I_C=30mA, Z_O=50\Omega$

Freq (MHz)	$ S_{11} $	$\angle S_{11}$	$ S_{21} $	$\angle S_{21}$	$ S_{12} $	$\angle S_{12}$	$ S_{22} $	$\angle S_{22}$
100	0.403	-88.7	23.847	116.6	0.028	63.5	0.561	-42.5
200	0.284	-126.8	13.541	96.9	0.045	63.7	0.380	-47.5
400	0.228	-167.6	7.074	78.2	0.081	61.5	0.295	-51.3
600	0.217	169.3	4.827	65.0	0.116	56.8	0.275	-57.2
800	0.213	151.0	3.687	52.8	0.153	50.3	0.276	-66.0
1000	0.211	134.3	3.034	42.2	0.188	43.2	0.281	-74.9
1200	0.216	117.8	2.579	30.8	0.223	35.5	0.283	-84.2
1400	0.222	103.1	2.262	20.4	0.256	27.9	0.280	-93.2
1600	0.238	87.6	2.029	10.3	0.289	20.3	0.271	-102.4
1800	0.248	74.2	1.840	0.3	0.321	12.6	0.265	-111.2
2000	0.271	61.6	1.706	-9.7	0.354	4.5	0.254	-120.5

$V_{CE}=5V, I_C=5mA, Z_O=50\Omega$

Freq (MHz)	$ S_{11} $	$\angle S_{11}$	$ S_{21} $	$\angle S_{21}$	$ S_{12} $	$\angle S_{12}$	$ S_{22} $	$\angle S_{22}$
100	0.807	-41.4	12.983	145.1	0.032	68.1	0.899	-20.6
200	0.627	-72.5	10.034	120.7	0.052	55.7	0.748	-32.3
400	0.399	-114.4	6.208	92.5	0.074	47.6	0.590	-42.7
600	0.314	-144.0	4.422	74.9	0.093	54.2	0.532	-49.4
800	0.266	-169.8	3.425	60.3	0.115	42.9	0.514	-56.8
1000	0.242	168.7	2.831	47.9	0.137	39.8	0.512	-64.6
1200	0.230	146.1	2.422	35.3	0.161	35.8	0.510	-72.6
1400	0.227	125.8	2.121	24.0	0.186	31.3	0.508	-80.8
1600	0.237	105.7	1.902	13.1	0.212	26.4	0.504	-89.1
1800	0.249	88.5	1.725	3.1	0.240	21.0	0.501	-97.2
2000	0.273	72.7	1.595	-7.2	0.271	14.8	0.497	-106.0

## 2SC5414

$V_{CE}=5V, I_C=10mA, Z_0=50\Omega$

Freq (MHz)	$ S_{11} $	$\angle S_{11}$	$ S_{21} $	$\angle S_{21}$	$ S_{12} $	$\angle S_{12}$	$ S_{22} $	$\angle S_{22}$
100	0.664	-52.5	19.156	134.9	0.029	65.7	0.807	-26.7
200	0.450	-85.2	13.004	110.4	0.044	58.6	0.621	-36.3
400	0.264	-124.5	7.320	86.3	0.069	55.5	0.490	-42.7
600	0.206	-153.2	5.075	70.9	0.095	53.3	0.450	-48.6
800	0.175	-178.9	3.884	58.1	0.122	48.7	0.444	-56.0
1000	0.163	159.7	3.190	46.8	0.150	43.8	0.446	-64.0
1200	0.156	135.8	2.715	35.0	0.178	37.8	0.446	-72.4
1400	0.158	115.9	2.376	24.3	0.204	31.8	0.448	-80.6
1600	0.174	95.5	2.127	14.0	0.233	25.5	0.439	-88.9
1800	0.188	77.7	1.938	4.1	0.262	19.0	0.434	-96.9
2000	0.212	62.7	1.788	-5.6	0.292	12.0	0.431	-105.3

$V_{CE}=5V, I_C=30mA, Z_0=50\Omega$

Freq (MHz)	$ S_{11} $	$\angle S_{11}$	$ S_{21} $	$\angle S_{21}$	$ S_{12} $	$\angle S_{12}$	$ S_{22} $	$\angle S_{22}$
100	0.423	-71.0	26.259	120.2	0.024	66.3	0.647	-32.7
200	0.258	-103.4	15.300	99.6	0.038	65.6	0.482	-36.2
400	0.155	-145.0	8.070	80.5	0.068	63.8	0.405	-39.6
600	0.129	173.2	5.493	67.5	0.098	59.1	0.388	-45.9
800	0.119	161.6	4.203	55.9	0.129	53.1	0.390	-54.2
1000	0.116	140.1	3.436	45.4	0.160	46.5	0.396	-62.7
1200	0.119	117.4	2.914	34.2	0.190	39.4	0.401	-71.8
1400	0.129	98.0	2.545	24.3	0.219	32.5	0.398	-80.2
1600	0.146	79.7	2.284	14.2	0.249	25.3	0.393	-88.6
1800	0.160	65.1	2.064	4.9	0.278	18.2	0.389	-96.9
2000	0.187	54.4	1.913	-4.9	0.308	10.7	0.386	-105.3

$V_{CE}=5V, I_C=50mA, Z_0=50\Omega$

Freq (MHz)	$ S_{11} $	$\angle S_{11}$	$ S_{21} $	$\angle S_{21}$	$ S_{12} $	$\angle S_{12}$	$ S_{22} $	$\angle S_{22}$
100	0.381	-82.7	25.958	114.6	0.023	65.6	0.611	-32.2
200	0.251	-120.2	14.443	95.9	0.037	65.8	0.465	-34.5
400	0.185	-164.6	7.561	78.0	0.067	64.0	0.405	-38.7
600	0.174	170.5	5.153	64.8	0.096	59.6	0.396	-46.0
800	0.163	149.4	3.904	52.8	0.127	53.5	0.401	-54.9
1000	0.167	130.7	3.194	41.9	0.157	47.1	0.406	-63.5
1200	0.176	112.8	2.696	31.0	0.187	39.8	0.410	-72.9
1400	0.184	96.6	2.358	20.5	0.216	32.9	0.409	-81.5
1600	0.197	80.7	2.115	10.1	0.246	25.9	0.404	-90.3
1800	0.214	68.1	1.908	0.1	0.275	18.8	0.400	-98.2
2000	0.243	55.0	1.766	-9.6	0.305	11.1	0.392	-106.2

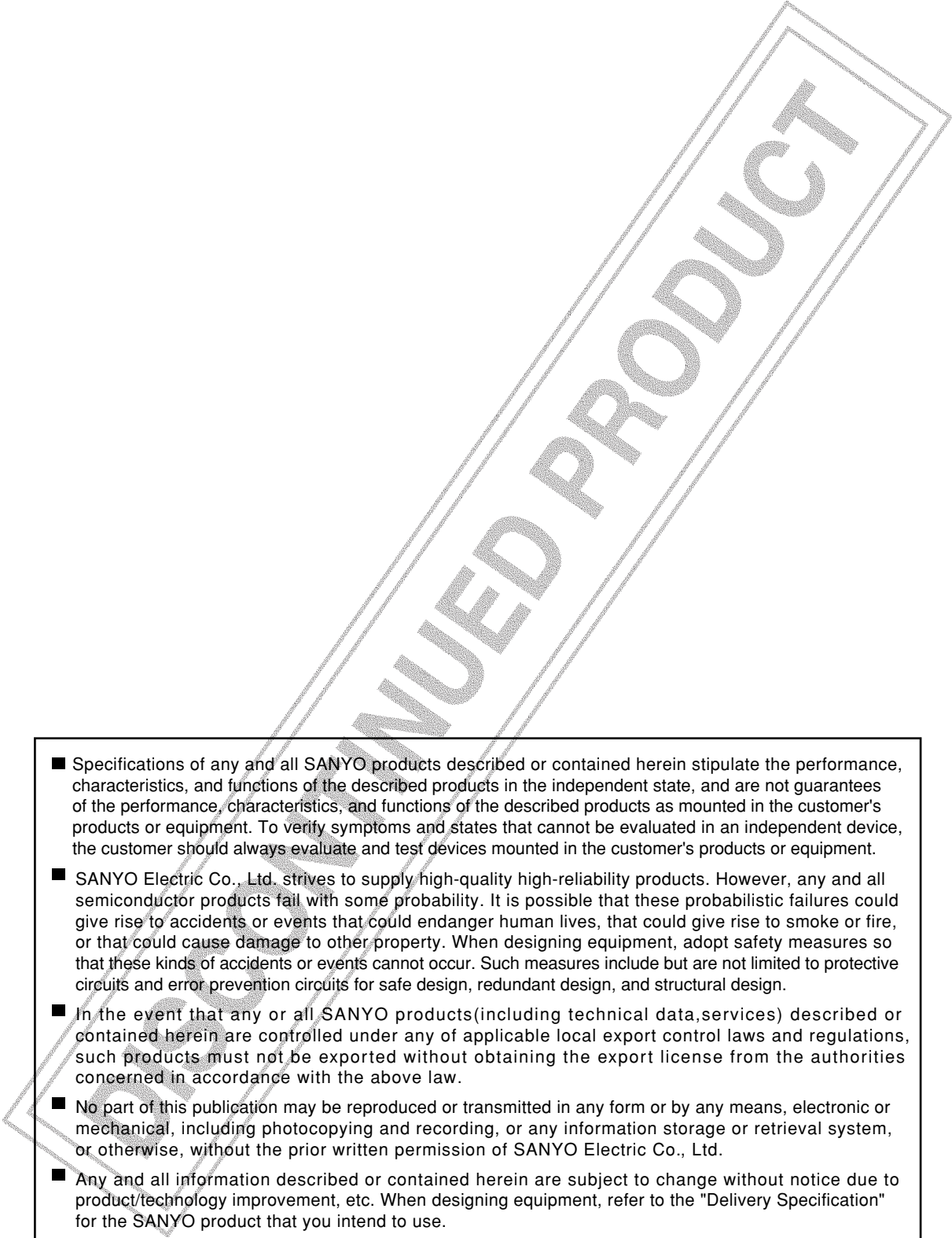
- 
- Specifications of any and all SANYO products described or contained herein stipulate the performance, characteristics, and functions of the described products in the independent state, and are not guarantees of the performance, characteristics, and functions of the described products as mounted in the customer's products or equipment. To verify symptoms and states that cannot be evaluated in an independent device, the customer should always evaluate and test devices mounted in the customer's products or equipment.
  - SANYO Electric Co., Ltd. strives to supply high-quality high-reliability products. However, any and all semiconductor products fail with some probability. It is possible that these probabilistic failures could give rise to accidents or events that could endanger human lives, that could give rise to smoke or fire, or that could cause damage to other property. When designing equipment, adopt safety measures so that these kinds of accidents or events cannot occur. Such measures include but are not limited to protective circuits and error prevention circuits for safe design, redundant design, and structural design.
  - In the event that any or all SANYO products (including technical data, services) described or contained herein are controlled under any of applicable local export control laws and regulations, such products must not be exported without obtaining the export license from the authorities concerned in accordance with the above law.
  - No part of this publication may be reproduced or transmitted in any form or by any means, electronic or mechanical, including photocopying and recording, or any information storage or retrieval system, or otherwise, without the prior written permission of SANYO Electric Co., Ltd.
  - Any and all information described or contained herein are subject to change without notice due to product/technology improvement, etc. When designing equipment, refer to the "Delivery Specification" for the SANYO product that you intend to use.
  - Information (including circuit diagrams and circuit parameters) herein is for example only ; it is not guaranteed for volume production. SANYO believes information herein is accurate and reliable, but no guarantees are made or implied regarding its use or any infringements of intellectual property rights or other rights of third parties.

This catalog provides information as of March, 2000. Specifications and information herein are subject to change without notice.