

**Features**

- Low power, pin-compatible replacement for ABT functions
- FCT-C speed at 4.2 ns
- Power-off disable outputs permits live insertion
- Edge-rate control circuitry for significantly improved noise characteristics
- Typical output skew < 250 ps
- ESD > 2000 V
- TSSOP (19.6-mil pitch) and SSOP (25-mil pitch) packages
- Extended commercial range of -40°C to +85°C
- $V_{CC} = 5V \pm 10\%$

**CY74FCT16373T Features:**

- 64 mA sink current (Com'1), 32 mA source current (Com'1)
- Typical  $V_{OLP}$  (ground bounce) < 1.0V at  $V_{CC} = 5V, T_A = 25^\circ C$

**CY74FCT162373T Features:**

- Balanced output drivers: 24 mA
- Reduced system switching noise
- Typical  $V_{OLP}$  (ground bounce) < 0.6V at  $V_{CC} = 5V, T_A = 25^\circ C$

**Functional Description**

CY74FCT16373T and CY74FCT162373T are 16-bit D-type latches designed for use in bus applications requiring high speed and low power. These devices can be used as two independent 8-bit latches or

as a single 16-bit latch by connecting the Output Enable (OE) and Latch (LE) inputs. Flow-through pinout and small shrink packaging aid in simplifying board layout. The output buffers are designed with power-off disable feature that allows live insertion of boards.

The CY74FCT16373T is ideally suited for driving high-capacitance loads and low-impedance backplanes.

The CY74FCT162373T has 24-mA balanced output drivers with current limiting resistors in the outputs. This reduces the need for external terminating resistors and provides for minimal undershoot and reduced ground bounce. The CY74FCT162373T is ideal for driving transmission lines.

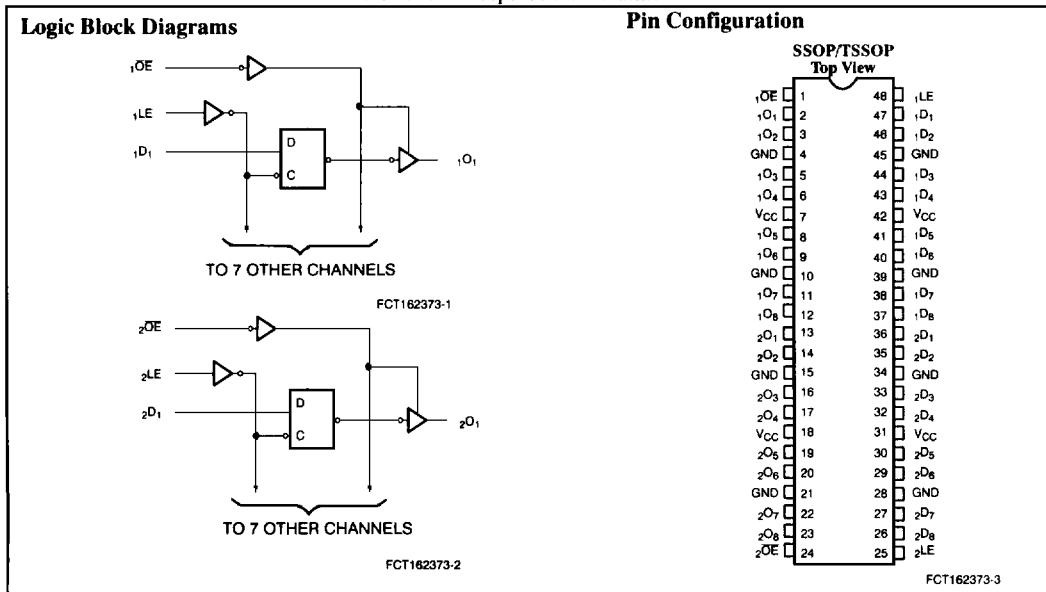
**Pin Description**

Name	Description
D	Data Inputs
LE	Latch Enable Inputs (Active HIGH)
OE	Output Enable Inputs (Active LOW)
O	Three-State Outputs

**Note:**

1. H = HIGH Voltage Level. L = LOW Voltage Level.  
X = Don't Care. Z = High Impedance.  
Q<sub>0</sub> = Previous state of flip-flop.

**Function Table<sup>[1]</sup>**

Inputs			Outputs
D	LE	OE	O
H	H	L	H
L	H	L	L
X	L	L	Q <sub>0</sub>
X	X	H	Z



**Maximum Ratings**<sup>[2, 3]</sup>

(Above which the useful life may be impaired. For user guidelines, not tested.)

Storage Temperature	Com'l	-55°C to +125°C
Ambient Temperature with Power Applied	Com'l	-55°C to +125°C
DC Input Voltage		-0.5V to +7.0V
DC Output Voltage		-0.5V to +7.0V
DC Output Current (Maximum Sink Current/Pin)		-60 to +120 mA

Power Dissipation	1.0W
Static Discharge Voltage (per MIL-STD-883, Method 3015)	>2001V

**Operating Range**

Range	Ambient Temperature	V <sub>CC</sub>
Commercial	-40°C to +85°C	5V ± 10%

**Electrical Characteristics Over the Operating Range**

Parameter	Description	Test Conditions	Min.	Typ. <sup>[4]</sup>	Max.	Unit
V <sub>IH</sub>	Input HIGH Voltage		2.0			V
V <sub>IL</sub>	Input LOW Voltage				0.8	V
V <sub>H</sub>	Input Hysteresis <sup>[5]</sup>			100		mV
V <sub>IK</sub>	Input Clamp Diode Voltage	V <sub>CC</sub> =Min., I <sub>IN</sub> =-18 mA		-0.7	-1.2	V
I <sub>IH</sub>	Input HIGH Current	V <sub>CC</sub> =Max., V <sub>I</sub> =V <sub>CC</sub>			±1	µA
I <sub>IL</sub>	Input LOW Current	V <sub>CC</sub> =Max., V <sub>I</sub> =GND			±1	µA
I <sub>OZH</sub>	High Impedance Output Current (Three-State Output pins)	V <sub>CC</sub> =Max., V <sub>OUT</sub> =2.7V			±1	µA
I <sub>OZL</sub>	High Impedance Output Current (Three-State Output pins)	V <sub>CC</sub> =Max., V <sub>OUT</sub> =0.5V			±1	µA
I <sub>OS</sub>	Short Circuit Current <sup>[6]</sup>	V <sub>CC</sub> =Max., V <sub>OUT</sub> =GND	-80	-140	-200	mA
I <sub>O</sub>	Output Drive Current <sup>[6]</sup>	V <sub>CC</sub> =Max., V <sub>OUT</sub> =2.5V	-50		-180	mA
I <sub>OFF</sub>	Power-Off Disable	V <sub>CC</sub> =0V, V <sub>OUT</sub> ≤4.5V			±1	µA

**Output Drive Characteristics for CY74FCT16373T**

Parameter	Description	Test Conditions	Min.	Typ. <sup>[4]</sup>	Max.	Unit
V <sub>OH</sub>	Output HIGH Voltage	V <sub>CC</sub> =Min., I <sub>OH</sub> =-3 mA	2.5	3.5		V
		V <sub>CC</sub> =Min., I <sub>OH</sub> =-15 mA	2.4	3.5		V
		V <sub>CC</sub> =Min., I <sub>OH</sub> =-32 mA	2.0	3.0		V
V <sub>OL</sub>	Output LOW Voltage	V <sub>CC</sub> =Min., I <sub>OL</sub> =64 mA		0.2	0.55	V

**Output Drive Characteristics for CY74FCT162373T**

Parameter	Description	Test Conditions	Min.	Typ. <sup>[4]</sup>	Max.	Unit
I <sub>ODL</sub>	Output LOW Current <sup>[6]</sup>	V <sub>CC</sub> =5V, V <sub>IN</sub> =V <sub>IH</sub> or V <sub>IL</sub> , V <sub>OUT</sub> =1.5V	60	115	150	mA
I <sub>ODH</sub>	Output HIGH Current <sup>[6]</sup>	V <sub>CC</sub> =5V, V <sub>IN</sub> =V <sub>IH</sub> or V <sub>IL</sub> , V <sub>OUT</sub> =1.5V	-60	-115	-150	mA
V <sub>OH</sub>	Output HIGH Voltage	V <sub>CC</sub> =Min., I <sub>OH</sub> =-24 mA	2.4	3.3		V
V <sub>OL</sub>	Output LOW Voltage	V <sub>CC</sub> =Min., I <sub>OL</sub> =24 mA		0.3	0.55	V

**Notes:**

- Operation beyond the limits set forth may impair the useful life of the device. Unless otherwise noted, these limits are over the operating free-air temperature range.
- Unused inputs must always be connected to an appropriate logic voltage level, preferably either V<sub>CC</sub> or ground.
- Typical values are at V<sub>CC</sub>=5.0V, T<sub>A</sub>=+25°C ambient.
- This parameter is guaranteed but not tested.
- Not more than one output should be shorted at a time. Duration of short should not exceed one second. The use of high-speed test apparatus and/or sample and hold techniques are preferable in order to minimize internal chip heating and more accurately reflect operational values. Otherwise prolonged shorting of a high output may raise the chip temperature well above normal and thereby cause invalid readings in other parametric tests. In any sequence of parameter tests, I<sub>OS</sub> tests should be performed last.

**Capacitance<sup>[5]</sup>** ( $T_A = +25^\circ\text{C}$ ,  $f = 1.0\text{ MHz}$ )

Parameter	Description	Test Conditions	Typ. <sup>[4]</sup>	Max.	Unit
$C_{IN}$	Input Capacitance	$V_{IN} = 0V$	4.5	6.0	pF
$C_{OUT}$	Output Capacitance	$V_{OUT} = 0V$	5.5	8.0	pF

**Power Supply Characteristics**

Parameter	Description	Test Conditions	Typ. <sup>[4]</sup>	Max.	Unit	
$I_{CC}$	Quiescent Power Supply Current	$V_{CC} = \text{Max.}$ $V_{IN} \leq 0.2V$ , $V_{IN} \geq V_{CC} - 0.2V$	5	500	$\mu\text{A}$	
$\Delta I_{CC}$	Quiescent Power Supply Current (TTL inputs HIGH)	$V_{CC} = \text{Max.}$ $V_{IN} = 3.4V$ <sup>[7]</sup>	0.5	1.5	mA	
$I_{CCD}$	Dynamic Power Supply Current <sup>[8]</sup>	$V_{CC} = \text{Max.}$ , One Input Toggling, 50% Duty Cycle, Outputs Open, $\overline{OE} = \text{GND}$	60	100	$\mu\text{A}/\text{MHz}$	
$I_C$	Total Power Supply Current <sup>[9]</sup>	$V_{CC} = \text{Max.}$ , $f_1 = 10\text{ MHz}$ , 50% Duty Cycle, Outputs Open, One Bit Toggling, $\overline{OE} = \text{GND}$ , $LE = V_{CC}$	$V_{IN} = V_{CC}$ or $V_{IN} = \text{GND}$	0.6	1.5	mA
			$V_{IN} = 3.4V$ or $V_{IN} = \text{GND}$	0.9	2.3	mA
		$V_{CC} = \text{Max.}$ , $f_1 = 2.5\text{ MHz}$ , 50% Duty Cycle, Outputs Open, Sixteen Bits Toggling, $\overline{OE} = \text{GND}$ , $LE = V_{CC}$	$V_{IN} = V_{CC}$ or $V_{IN} = \text{GND}$	2.4	4.5 <sup>[10]</sup>	mA
			$V_{IN} = 3.4V$ or $V_{IN} = \text{GND}$	6.4	16.5 <sup>[10]</sup>	mA

**Notes:**

- Per TTL driven input ( $V_{IN} = 3.4V$ ); all other inputs at  $V_{CC}$  or GND.
- This parameter is not directly testable, but is derived for use in Total Power Supply calculations.
- $I_C = I_{\text{QUIESCENT}} + I_{\text{INPUTS}} + I_{\text{DYNAMIC}}$   
 $I_C = I_{CC} + \Delta I_{CC} D_H N_T + I_{CCD} (f_1/2 + f_1 N_1)$
- $I_{CC}$  = Quiescent Current with CMOS input levels
- $\Delta I_{CC}$  = Power Supply Current for a TTL HIGH input ( $V_{IN} = 3.4V$ )
- $D_H$  = Duty Cycle for TTL inputs HIGH

- $N_T$  = Number of TTL inputs at  $D_H$
  - $I_{CCD}$  = Dynamic Current caused by an input transition pair (HLH or LHL)
  - $f_1$  = Clock frequency for registered devices, otherwise zero
  - $f_1$  = Input signal frequency
  - $N_1$  = Number of inputs changing at  $f_1$
- All currents are in milliamps and all frequencies are in megahertz.
- Values for these conditions are examples of the  $I_{CC}$  formula. These limits are guaranteed but not tested.



Switching Characteristics Over the Operating Range

Parameter	Description	CY74FCT16373T CY74FCT162373T		CY74FCT16373AT CY74FCT162373AT		CY74FCT16373CT CY74FCT162373CT		Unit	Fig. No. <sup>[12]</sup>
		Min. <sup>[11]</sup>	Max.	Min. <sup>[11]</sup>	Max.	Min. <sup>[11]</sup>	Max.		
t <sub>PLH</sub> t <sub>PHL</sub>	Propagation Delay D to O	1.5	8.0	1.5	5.2	1.5	4.2	ns	1, 3
t <sub>PLH</sub> t <sub>PHL</sub>	Propagation Delay LE to O	2.0	13.0	2.0	6.7	2.0	5.5	ns	1, 5
t <sub>PZH</sub> t <sub>PZL</sub>	Output Enable Time	1.5	12.0	1.5	6.1	1.5	5.5	ns	1, 7, 8
t <sub>PHZ</sub> t <sub>PLZ</sub>	Output Disable Time	1.5	7.5	1.5	5.5	1.5	5.0	ns	1, 7, 8
t <sub>SU</sub>	Set-Up Time HIGH or LOW, D to LE	2.0		2.0		2.0		ns	9
t <sub>H</sub>	Hold Time HIGH or LOW, D to LE	1.5		1.5		1.5		ns	9
t <sub>w</sub>	LE Pulse Width HIGH	6.0		3.3		3.3		ns	5
t <sub>SK(O)</sub>	Output Skew <sup>[13]</sup>		0.5		0.5		0.5	ns	—

Ordering Information CY74FCT16373

Speed (ns)	Ordering Code	Package Name	Package Type	Operating Range
4.2	CY74FCT16373CTPAC	Z48	48-Lead (240-Mil) TSSOP	Commercial
	CY74FCT16373CTPVC	O48	48-Lead (300-Mil) SSOP	
5.2	CY74FCT16373ATPAC	Z48	48-Lead (240-Mil) TSSOP	Commercial
	CY74FCT16373ATPVC	O48	48-Lead (300-Mil) SSOP	
8.0	CY74FCT16373TPAC	Z48	48-Lead (240-Mil) TSSOP	Commercial
	CY74FCT16373TPVC	O48	48-Lead (300-Mil) SSOP	

Ordering Information CY74FCT162373

Speed (ns)	Ordering Code	Package Name	Package Type	Operating Range
4.2	CY74FCT162373CTPAC	Z48	48-Lead (240-Mil) TSSOP	Commercial
	CY74FCT162373CTPVC	O48	48-Lead (300-Mil) SSOP	
5.2	CY74FCT162373ATPAC	Z48	48-Lead (240-Mil) TSSOP	Commercial
	CY74FCT162373ATPVC	O48	48-Lead (300-Mil) SSOP	
8.0	CY74FCT162373TPAC	Z48	48-Lead (240-Mil) TSSOP	Commercial
	CY74FCT162373TPVC	O48	48-Lead (300-Mil) SSOP	

Notes:

- Minimum limits are guaranteed but not tested on Propagation Delays.
- See "Parameter Measurement Information" in the General Information Section.
- Skew between any two outputs of the same package switching in the same direction. This parameter is guaranteed by design.

Document #: 38-00386