



**FAST CMOS  
PARITY BUS  
TRANSCEIVER**

- IDT 54/74FCT833A/B**
- IDT 54/74FCT834A/B\***
- IDT 54/74FCT853A/B**
- IDT 54/74FCT854A/B\***

**FEATURES:**

- Equivalent to AMD's Am29833-34 and Am29853-54 bipolar parity bus transceivers in pinout/function, speeds and output drive over full temperature and voltage supply extremes
- High speed bidirectional bus transceiver for processor-organized devices
  - Non-inverting propagation delay = 7.0ns max.
  - Inverting propagation delay = 7.0ns max.
- Buffered direction three state control
- Error Flag with open-drain output
- $I_{OL} = 48mA$  (commercial) and  $32mA$  (military)
- TTL Input and output level compatible
- CMOS output level compatible
- Substantially lower input current levels than AMD's bipolar Am29800 series ( $5\mu A$  max.)
- Available in Plastic DIP, Cerdip, LCC, PLCC and SOIC
- Product available in Radiation Tolerant and Enhanced versions
- Military product compliant to MIL-STD-883, Class B

**DESCRIPTION:**

*T-52-31*

The IDT54/74FCT833/34/53/54 are high-performance bus transceivers designed for two-way communications. They each contain an 8-bit data path from the R (port) to the T (port), a 8-bit data path from the T (port) to the R (port), and a 9-bit parity checker/generator. Two options are available: the IDT54/74FCT833/34 register option and the IDT54/74FCT853/54 latch option. With the register option, the error flag can be clocked and stored in a register and read at the ERR output. The clear (CLR) input is used to clear the error flag register. With the latch option, the error can be either passed, stored, sampled or cleared at the error flag output by using the EN and CLR controls.

The output enables  $\overline{OE}_T$  and  $\overline{OE}_R$  are used to force the port outputs to the high-impedance state so that the device can drive bus lines directly. In addition,  $\overline{OE}_R$  and  $\overline{OE}_T$  can be used to force a parity error by enabling both lines simultaneously. This transmission of inverted parity gives the designer more system diagnostic capability. The IDT54/74FCT833 and IDT54/74FCT853 are non-inverting, while the IDT54/74FCT834 and IDT54/74FCT854 present inverting data at the outputs. The devices are specified at 48mA and 32mA output sink current over the commercial and military temperature ranges, respectively.

**FUNCTIONAL BLOCK DIAGRAM**

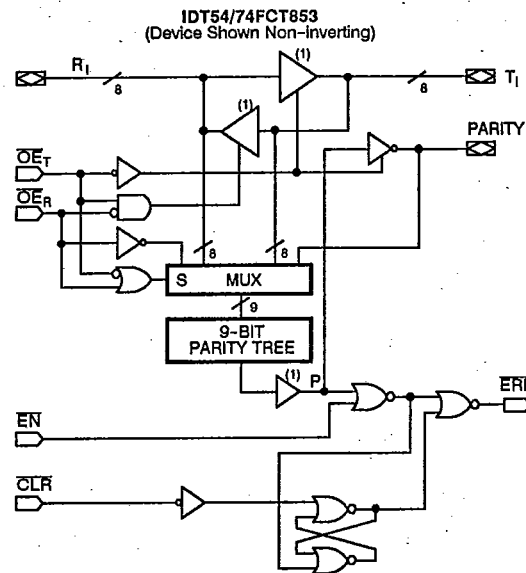
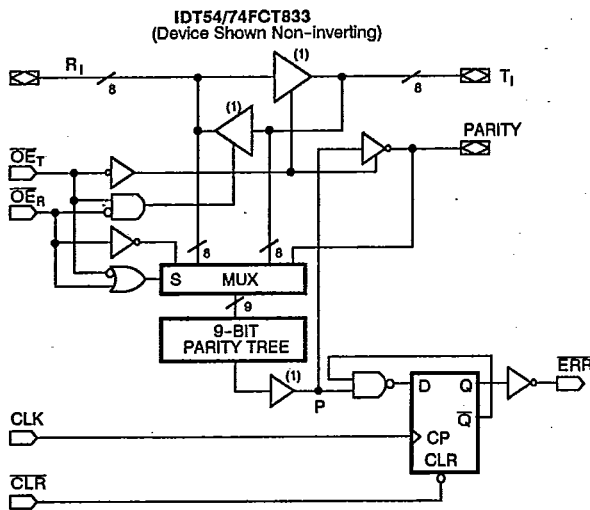

**10**

**NOTE:**

1: Non-inverting buffer for IDT54/74FCT833/53, inverting buffer for IDT54/74FCT834/54, note that the inverting device converts the positive logic "R" bus levels to negative levels on "T" bus.

CEMOS is a trademark of Integrated Device Technology, Inc.

\*Advance information only for IDT54/74FCT834 and IDT54/74FCT854.

**MILITARY AND COMMERCIAL TEMPERATURE RANGES**

**JANUARY 1989**

IDT54/74FCT833A/B, IDT54/74FCT834A/B, IDT54/74FCT853A/B AND IDT54/74FCT854A/B FAST CMOS PARITY BUS TRANSCEIVER

MILITARY AND COMMERCIAL TEMPERATURE RANGES

PIN CONFIGURATIONS

T-52-31

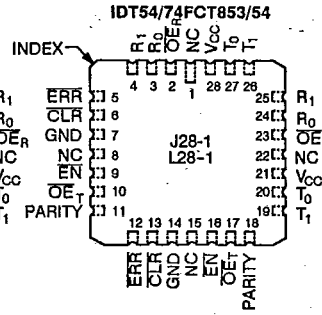
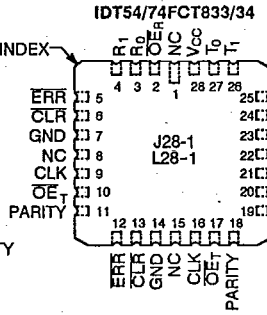
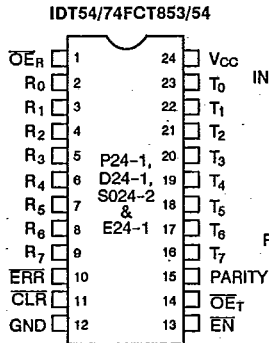
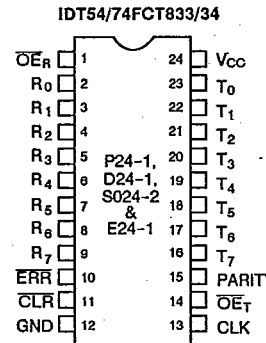

DIP/SOIC/CERPACK TOP VIEW

LCC/PLCC TOP VIEW

PIN DESCRIPTION

PIN NO.	NAME	I/O	DESCRIPTION
<b>IDT54/74FCT833/34</b>			
1	OE <sub>R</sub>	I	RECEIVE enable input.
2-9	R <sub>i</sub>	I/O	8-bit RECEIVE data output.
10	ERR	O	Output from fault registers. Registers detection of odd parity fault on using clock edge (CLK). A registered ERR output remains low until cleared. Open drain output, requires pull up resistor.
11	CLR	O	Clears the fault register output.
16-23	T <sub>i</sub>	I/O	8-bit TRANSMIT data output.
15	PARITY	I/O	1-bit PARITY output.
14	OE <sub>T</sub>	I	TRANSMIT enable input.
13	CLK	I	External clock pulse input for fault register flag.
<b>IDT54/74FCT853/54</b>			
1	OE <sub>R</sub>	I	RECEIVE enable input.
2-9	R <sub>i</sub>	I/O	8-bit RECEIVE data output.
10	ERR	O	Output from fault latches. Latches detection of odd parity fault on active enable EN. A latched ERR output remains LOW until cleared. Open drain output, requires pull up resistor.
11	CLR	O	Clears the fault latch output.
16-23	T <sub>i</sub>	I/O	8-bit TRANSMIT data output.
15	PARITY	I/O	1-bit PARITY output.
14	OE <sub>T</sub>	I	TRANSMIT enable input.
13	EN	I	Enable latch input for fault flag.

ERROR FLAG OUTPUT TRUTH TABLE

IDT54/74FCT833/IDT54/74FCT834 (REGISTER OPTION)

INPUTS		INTERNAL TO DEVICE	OUTPUTS PRE-STATE	OUTPUT	FUNCTION
CLR	CLK	POINT "P"	ERR <sub>n-1</sub>	ERR	
H	↑	H	H	H	Sample (1's Capture)
H	↑	-	L	L	
H	↑	L	-	L	
L	-	-	-	H	Clear

OE<sub>T</sub> is HIGH and OE<sub>R</sub> is LOW.

IDT54/74FCT853/IDT54/74FCT854 (LATCH OPTION)

INPUTS		INTERNAL TO DEVICE	OUTPUTS PRE-STATE	OUTPUT	FUNCTION
EN	CLR	POINT "P"	ERR <sub>n-1</sub>	ERR	
L	L	L	-	L	Pass
L	L	H	-	H	
L	H	L	-	L	Sample (1's Capture)
L	H	H	-	H	
H	L	-	-	H	Clear
H	H	-	L	L	Store
H	H	-	H	H	

OE<sub>T</sub> is HIGH and OE<sub>R</sub> is LOW.



FUNCTION TABLES (CONTINUED)

T-52-31

IDT54/74FCT853 NON-INVERTING LATCH OPTION

INPUTS						OUTPUTS				FUNCTION
OE <sub>T</sub>	OE <sub>R</sub>	CLR	EN	R <sub>i</sub> (Σ OF H'S)	T <sub>i</sub> INCL PARITY (Σ OF H'S)	R <sub>i</sub>	T <sub>i</sub>	PARITY	ERR <sup>(1)</sup>	
L	H	-	-	H (Odd)	NA	NA	H	L	NA	Transmit data from R Port to T Port with parity; receiving path is disabled.
L	H	-	-	H (Even)	NA	NA	H	L	NA	
L	H	-	-	L (Odd)	NA	NA	L	H	NA	
L	H	-	-	L (Even)	NA	NA	L	H	NA	
H	L	L	L	NA	H (Odd)	H	NA	NA	H	Receive data from T Port to R Port with parity test resulting in flag; transmitting path is disabled.
H	L	L	L	NA	H (Even)	H	NA	NA	L	
H	L	L	L	NA	L (Odd)	L	NA	NA	H	
H	L	L	L	NA	L (Even)	L	NA	NA	L	
H	L	H	L	NA	H (Odd)	H	NA	NA	H	Receive data from T Port to R Port, pass the error test resulting to error flag; transmitting path is disabled.
H	L	H	L	NA	H (Even)	H	NA	NA	L	
H	L	H	L	NA	L (Odd)	L	NA	NA	H	
H	L	H	L	NA	L (Even)	L	NA	NA	L	
H	L	H	H	NA	-	-	NA	NA	*	Store the state of error flag register.
-	-	L	H	-	-	-	NA	NA	H	Clear the state of error flag register.
H	H	H	H	-	-	Z	Z	Z	*	Both transmitting and receiving paths are disabled. Parity logic defaults to transmit mode.
H	H	L	H	-	-	Z	Z	Z	H	
H	H	-	L	L (Odd)	-	Z	Z	Z	H	
H	H	-	L	H (Even)	-	Z	Z	Z	L	
L	L	-	-	H (Odd)	NA	NA	H	H	NA	Forced-error checking.
L	L	-	-	H (Even)	NA	NA	H	L	NA	
L	L	-	-	L (Odd)	NA	NA	L	H	NA	
L	L	-	-	L (Even)	NA	NA	L	L	NA	

IDT54/74FCT854 INVERTING LATCH OPTION <sup>(2)</sup>

INPUTS						OUTPUTS				FUNCTION
OE <sub>T</sub>	OE <sub>R</sub>	CLR	EN	R <sub>i</sub> (Σ OF H'S)	T <sub>i</sub> INCL PARITY (Σ OF H'S)	R <sub>i</sub>	T <sub>i</sub>	PARITY	ERR <sup>(1)</sup>	
L	H	-	-	H (Odd)	NA	NA	L	H	NA	Transmit data from R Port to T Port with parity; receiving path is disabled.
L	H	-	-	H (Even)	NA	NA	L	L	NA	
L	H	-	-	L (Odd)	NA	NA	H	H	NA	
L	H	-	-	L (Even)	NA	NA	H	L	NA	
H	L	L	L	NA	H (Odd)	L	NA	NA	H	Receive data from T Port to R Port with parity test resulting in flag; transmitting path is disabled.
H	L	L	L	NA	H (Even)	L	NA	NA	L	
H	L	L	L	NA	L (Odd)	H	NA	NA	H	
H	L	L	L	NA	L (Even)	H	NA	NA	L	
H	L	H	L	NA	H (Odd)	L	NA	NA	H	Receive data from T Port to R Port, pass the error test resulting to error flag; transmitting path is disabled.
H	L	H	L	NA	H (Even)	L	NA	NA	L	
H	L	H	L	NA	L (Odd)	H	NA	NA	H	
H	L	H	L	NA	L (Even)	H	NA	NA	L	
H	L	H	H	NA	-	-	NA	NA	*	Store the state of error flag register.
-	-	L	H	-	-	-	NA	NA	H	Clear the state of error flag register.
H	H	H	H	-	-	Z	Z	Z	*	Both transmitting and receiving paths are disabled. Parity logic defaults to transmit mode.
H	H	L	H	-	-	Z	Z	Z	H	
H	H	-	L	L (Odd)	-	Z	Z	Z	L	
H	H	-	L	H (Even)	-	Z	Z	Z	H	
L	L	-	-	H (Odd)	NA	NA	L	L	NA	Forced-error checking.
L	L	-	-	H (Even)	NA	NA	L	H	NA	
L	L	-	-	L (Odd)	NA	NA	H	L	NA	
L	L	-	-	L (Even)	NA	NA	H	H	NA	

H = High

L = Low

Z = High Impedance

NC = No Change

NA = Not Applicable

\*Store the Error State of the Last Receive Cycle

- = Don't Care or Irrelevant

Odd = Odd number of logic one's

Even = Even number of logic one's

i = 0, 1, 2, 3, 4, 5, 6, 7

NOTES:

1. Output state assumes HIGH output pre-state.

2. Note that for negative logic levels on the B Port, an "H" represents a logic "0" while an "L" represents a logic "1".

T-52-31

ABSOLUTE MAXIMUM RATINGS (1)

SYMBOL	RATING	COMMERCIAL	MILITARY	UNIT
V <sub>TERM</sub> (2)	Terminal Voltage with Respect to GND	-0.5 to +7.0	-0.5 to +7.0	V
V <sub>TERM</sub> (3)	Terminal Voltage with Respect to GND	-0.5 to V <sub>CC</sub>	-0.5 to V <sub>CC</sub>	V
T <sub>A</sub>	Operating Temperature	0 to +70	-55 to +125	°C
T <sub>BIAS</sub>	Temperature Under Bias	-55 to +125	-65 to +135	°C
T <sub>STG</sub>	Storage Temperature	-55 to +125	-65 to +150	°C
P <sub>T</sub>	Power Dissipation	0.5	0.5	W
I <sub>OUT</sub>	DC Output Current	120	120	mA

CAPACITANCE (T<sub>A</sub> = +25°C, f = 1.0MHz)

SYMBOL	PARAMETER(1)	CONDITIONS	TYP.	MAX.	UNIT
C <sub>IN</sub>	Input Capacitance	V <sub>IN</sub> = 0V	6	10	pF
C <sub>I/O</sub>	I/O Capacitance	V <sub>OUT</sub> = 0V	8	12	pF

NOTE:

1. This parameter is guaranteed by characterization and not tested.

NOTES:

1. Stresses greater than those listed under ABSOLUTE MAXIMUM RATINGS may cause permanent damage to the device. This is a stress rating only and functional operation of the device at these or any other conditions above those indicated in the operational sections of this specification is not implied. Exposure to absolute maximum rating conditions for extended periods may affect reliability.
2. Input and V<sub>CC</sub> terminals only.
3. Output and I/O terminals only.

DC ELECTRICAL CHARACTERISTICS OVER OPERATING RANGE

Following Conditions Apply Unless Otherwise Specified:

V<sub>LC</sub> = 0.2V; V<sub>HC</sub> = V<sub>CC</sub> - 0.2V

Commercial: T<sub>A</sub> = 0°C to +70°C; V<sub>CC</sub> = 5.0V ± 5%

Military: T<sub>A</sub> = -55°C to +125°C; V<sub>CC</sub> = 5.0V ± 10%

SYMBOL	PARAMETER	TEST CONDITIONS (1)	MIN.	TYP.(2)	MAX.	UNIT	
V <sub>IH</sub>	Input HIGH Level	Guaranteed Logic High Level	2.0	-	-	V	
V <sub>IL</sub>	Input LOW Level	Guaranteed Logic Low Level	-	-	0.8	V	
I <sub>IH</sub>	Input HIGH Current (Except I/O pins)	V <sub>CC</sub> = Max. V <sub>I</sub> = V <sub>CC</sub> V <sub>I</sub> = 2.7V V <sub>I</sub> = 0.5V V <sub>I</sub> = GND	-	-	5	μA	
I <sub>IL</sub>	Input LOW Current (Except I/O pins)		-	-	-5(4)		
I <sub>IH</sub>	Input HIGH Current (I/O pins only)		V <sub>CC</sub> = Max. V <sub>I</sub> = V <sub>CC</sub> V <sub>I</sub> = 2.7V V <sub>I</sub> = 0.5V V <sub>I</sub> = GND	-	-		15
I <sub>IL</sub>	Input LOW Current (I/O pins only)	-	-	-15(4)			
V <sub>IK</sub>	Clamp Diode Voltage	V <sub>CC</sub> = Min., I <sub>N</sub> = -18mA	-	-0.7	-1.2	V	
I <sub>OS</sub>	Short Circuit Current	V <sub>CC</sub> = Max.(3), V <sub>O</sub> = GND	-60	-120	-	mA	
V <sub>OH</sub>	Output HIGH Voltage (Except ERR)	V <sub>CC</sub> = 3V, V <sub>IN</sub> = V <sub>LC</sub> or V <sub>HC</sub> , I <sub>OH</sub> = -32μA	V <sub>HC</sub>	V <sub>CC</sub>	-	V	
		V <sub>CC</sub> = Min., V <sub>IN</sub> = V <sub>IH</sub> or V <sub>IL</sub>	I <sub>OH</sub> = -300μA	V <sub>HC</sub>	V <sub>CC</sub>		-
			I <sub>OH</sub> = -15mA MIL. I <sub>OH</sub> = -24mA COM'L.	2.4	4.3		-
V <sub>OL</sub>	Output LOW Voltage	V <sub>CC</sub> = 3V, V <sub>IN</sub> = V <sub>LC</sub> or V <sub>HC</sub> , I <sub>OL</sub> = 300μA	-	GND	V <sub>LC</sub>	V	
		V <sub>CC</sub> = Min. All other outputs V <sub>IN</sub> = V <sub>IH</sub> or V <sub>IL</sub> ERR	I <sub>OL</sub> = 300μA	-	GND		V <sub>LC</sub>
			I <sub>OL</sub> = 32mA MIL.	-	0.3		0.5
			I <sub>OL</sub> = 48mA COM'L.	-	0.3		0.5
V <sub>H</sub>	Input Hysteresis on T <sub>I</sub> and R <sub>I</sub>	-	-	200	-	mV	

10

NOTES:

1. For conditions shown as max. or min., use appropriate value specified under Electrical Characteristics for the applicable device type.
2. Typical values are at V<sub>CC</sub> = 5.0V, +25°C ambient and maximum loading.
3. Not more than one output should be shorted at one time. Duration of the short circuit test should not exceed one second.
4. This parameter is guaranteed but not tested.

T-52-31

POWER SUPPLY CHARACTERISTICS

$V_{LC} = 0.2V$ ;  $V_{HC} = V_{CC} - 0.2V$

SYMBOL	PARAMETER	TEST CONDITIONS (1)		MIN.	TYP.(2)	MAX.	UNIT
$I_{CC}$	Quiescent Power Supply Current	$V_{CC} = \text{Max.}$ $V_{IN} \leq V_{HC}; V_{IN} \leq V_{LC}$ $f_i = 0$		-	0.001	1.5	mA
$\Delta I_{CC}$	Quiescent Power Supply Current TTL Inputs HIGH	$V_{CC} = \text{Max.}$ $V_{IN} = 3.4V(3)$		-	0.5	2.0	mA
$I_{CCD}$	Dynamic Power Supply Current(4)	$V_{CC} = \text{Max.}$ Outputs Open $\overline{OE}_T = \overline{OE}_R = \text{GND}$ One Input Toggling 50% Duty Cycle	$V_{IN} \geq V_{HC}$ $V_{IN} \leq V_{LC}$	-	0.15	0.25	mA/MHz
$I_{CC}$	Total Power Supply Current(6)	$V_{CC} = \text{Max.}$ Outputs Open $f_{CP} = 10\text{MHz (CLK or EN)}$ 50% Duty Cycle $\overline{OE}_T = \text{GND}$ $\overline{OE}_R = V_{CC}$ $f_i = 2.5\text{MHz}$ One Input Toggling	$V_{IN} \geq V_{HC};$ $V_{IN} \leq V_{LC}$ (FCT)	-	1.2	3.4	mA
			$V_{IN} = 3.4V$ $V_{IN} = \text{GND}$	-	1.6	5.4	
		$V_{CC} = \text{Max.}$ Outputs Open $f_{CP} = 10\text{MHz (CLK or EN)}$ 50% Duty Cycle $\overline{OE}_T = \text{GND}$ $f_i = 2.5\text{MHz}$ $\overline{OE}_R = V_{CC}$ Eight Inputs Toggling	$V_{IN} \geq V_{HC};$ $V_{IN} \leq V_{LC}$ (FCT)	-	3.8	7.8(5)	
			$V_{IN} = 3.4V$ $V_{IN} = \text{GND}$	-	6.0	16.8(5)	

NOTES:

- For conditions shown as max. or min., use appropriate value specified under Electrical Characteristics for the applicable device type.
- Typical values are at  $V_{CC} = 5.0V$ ,  $+25^\circ\text{C}$  ambient and maximum loading.
- Per TTL driven input ( $V_{IN} = 3.4V$ ); all other inputs at  $V_{CC}$  or GND.
- This parameter is not directly testable, but is derived for use in Total Power Supply calculations.
- Values for these conditions are examples of the  $I_{CC}$  formula. These limits are guaranteed but not tested.
- $I_C = I_{\text{QUIESCENT}} + I_{\text{INPUTS}} + I_{\text{DYNAMIC}}$   
 $I_C = I_{CC} + \Delta I_{CC} D_H N_T + I_{CCD} (f_{CP}/2 + f_i N_i)$   
 $I_{CC}$  = Quiescent Current  
 $\Delta I_{CC}$  = Power Supply Current for a TTL High Input ( $V_{IN} = 3.4V$ )  
 $D_H$  = Duty Cycle for TTL Inputs High  
 $N_T$  = Number of TTL Inputs at  $D_H$   
 $I_{CCD}$  = Dynamic Current Caused by an Input Transition Pair (HLH or LHL)  
 $f_{CP}$  = Clock Frequency for Register Devices (Zero for Non-Register Devices)  
 $f_i$  = Input Frequency  
 $N_i$  = Number of Inputs at  $f_i$   
 All currents are in milliamps and all frequencies are in megahertz.

T-52-31

SWITCHING CHARACTERISTICS OVER TEMPERATURE RANGE

PARAMETERS	DESCRIPTION	TEST CONDITIONS <sup>(4)</sup>	IDT54/74FCT8XXA <sup>(3)</sup>				IDT54/74FCT8XXB <sup>(3)</sup>				UNIT	
			COM'L.		MIL.		COM'L.		MIL.			
			MIN.	MAX.	MIN.	MAX.	MIN.	MAX.	MIN.	MAX.		
t <sub>PLH</sub>	Propagation Delay R <sub>I</sub> to T <sub>I</sub> , T <sub>I</sub> to R <sub>I</sub>	C <sub>L</sub> = 50pF	-	10.0	-	14.0	-	7.0	-	10.0	ns	
t <sub>PHL</sub>			-	10.0	-	14.0	-	7.0	-	10.0	ns	
t <sub>PLH</sub>		C <sub>L</sub> = 300pF <sup>(6)</sup>	-	17.5	-	21.5	-	14.5	-	17.5	ns	
t <sub>PHL</sub>			-	17.5	-	21.5	-	14.5	-	17.5	ns	
t <sub>PLH</sub>	Propagation Delay R <sub>I</sub> to PARITY	C <sub>L</sub> = 50pF	-	15.0	-	20.0	-	10.5	-	14.0	ns	
t <sub>PHL</sub>			-	15.0	-	20.0	-	10.5	-	14.0	ns	
t <sub>PLH</sub>		C <sub>L</sub> = 300pF <sup>(6)</sup>	-	22.5	-	27.5	-	18.0	-	21.5	ns	
t <sub>PHL</sub>			-	22.5	-	27.5	-	18.0	-	21.5	ns	
t <sub>PZH</sub>	Output Enable Time OE <sub>R</sub> , OE <sub>T</sub> to R <sub>I</sub> , T <sub>I</sub>	C <sub>L</sub> = 50pF	-	12.0	-	16.0	-	8.5	-	11.0	ns	
t <sub>PZL</sub>			-	12.0	-	16.0	-	8.5	-	11.0	ns	
t <sub>PZH</sub>		C <sub>L</sub> = 300pF <sup>(6)</sup>	-	19.5	-	23.5	-	16.0	-	18.5	ns	
t <sub>PZL</sub>			-	19.5	-	23.5	-	16.0	-	18.5	ns	
t <sub>PHZ</sub>	Output Disable Time OE <sub>R</sub> , OE <sub>T</sub> to R <sub>I</sub> , T <sub>I</sub>	C <sub>L</sub> = 5pF <sup>(6)</sup>	-	10.7	-	14.7	-	7.2	-	9.8	ns	
t <sub>PLZ</sub>			-	10.7	-	14.7	-	7.2	-	9.8	ns	
t <sub>PHZ</sub>		C <sub>L</sub> = 50pF	-	12.0	-	16.0	-	8.5	-	11.0	ns	
t <sub>PLZ</sub>			-	12.0	-	16.0	-	8.5	-	11.0	ns	
t <sub>SU</sub>	T <sub>I</sub> , PARITY to CLK Set-up Time <sup>(1)</sup>	C <sub>L</sub> = 50pF	12.0	-	16.0	-	8.5	-	11.0	-	ns	
t <sub>H</sub>	T <sub>I</sub> , PARITY to CLK Hold Time <sup>(1)</sup>		0	-	0	-	0	-	0	-	ns	
t <sub>SU</sub>	Clear Recovery Time CLR to CLK <sup>(2)</sup>		15.0	-	20.0	-	10.5	-	14.0	-	ns	
t <sub>W</sub>	Clock Pulse Width <sup>(1)</sup>		HIGH	7.0	-	9.5	-	5.5	-	7.0	-	ns
			LOW	7.0	-	9.5	-	5.5	-	7.0	-	ns
t <sub>W</sub>	Clear Pulse Width		LOW	7.0	-	9.5	-	5.5	-	7.0	-	ns
t <sub>PHL</sub>	Propagation Delay CLK to ERR <sup>(1)</sup>	C <sub>L</sub> = 50pF	-	12.0	-	16.0	-	8.5	-	11.0	ns	
t <sub>PLH</sub>	Propagation Delay CLR to ERR	C <sub>L</sub> = 50pF	-	16.0	-	20.0	-	15.0	-	18.0	ns	
t <sub>PLH</sub>	Propagation-Delay T <sub>I</sub> , PARITY TO ERR (PASS Mode Only) IDT54/74FCT853 and IDT54/74FCT854	C <sub>L</sub> = 50pF	-	15.0	-	20.0	-	10.5	-	14.0	ns	
t <sub>PHL</sub>			-	15.0	-	20.0	-	10.5	-	14.0	ns	
t <sub>PLH</sub>	Propagation Delay OE <sub>R</sub> to PARITY	C <sub>L</sub> = 50pF	-	15.0	-	20.0	-	10.5	-	14.0	ns	
t <sub>PHL</sub>			-	15.0	-	20.0	-	10.5	-	14.0	ns	
t <sub>PLH</sub>		C <sub>L</sub> = 300pF <sup>(6)</sup>	-	22.5	-	27.5	-	18.0	-	21.5	ns	
t <sub>PHL</sub>			-	22.5	-	27.5	-	18.0	-	21.5	ns	

10

NOTES:

1. For IDT54/74FCT853/54, replace CLK with EN.
2. Not applicable to IDT54/74FCT853/54.
3. XX represents 33, 34, 53 and 54.
4. See test circuit and waveforms.
5. Minimum limits are guaranteed but not tested on Propagation Delays.
6. These parameters are guaranteed but not tested.

ORDERING INFORMATION

T-52-31

