

TLC271, TLC271A, TLC271B LinCMOS™ PROGRAMMABLE LOW-POWER OPERATIONAL AMPLIFIERS

SLOS090C – NOVEMBER 1987 – REVISED AUGUST 1997

- **Input Offset Voltage Drift . . . Typically 0.1 μ V/Month, Including the First 30 Days**
- **Wide Range of Supply Voltages Over Specified Temperature Range:**
 0°C to 70°C . . . 3 V to 16 V
 –40°C to 85°C . . . 4 V to 16 V
 –55°C to 125°C . . . 5 V to 16 V
- **Single-Supply Operation**
- **Common-Mode Input Voltage Range Extends Below the Negative Rail (C-Suffix and I-Suffix Types)**
- **Low Noise . . . 25 nV/ $\sqrt{\text{Hz}}$ Typically at f = 1 kHz (High-Bias Mode)**
- **Output Voltage Range includes Negative Rail**
- **High Input Impedance . . . 10¹² Ω Typ**
- **ESD-Protection Circuitry**
- **Small-Outline Package Option Also Available in Tape and Reel**
- **Designed-In Latch-Up Immunity**

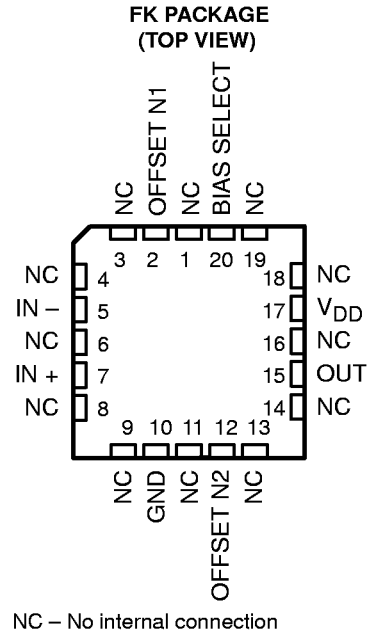
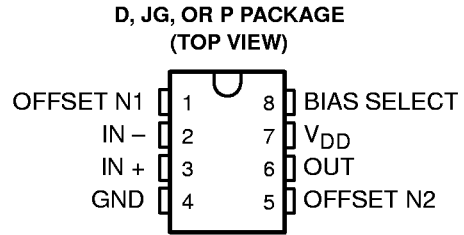

description

The TLC271 operational amplifier combines a wide range of input offset voltage grades with low offset voltage drift and high input impedance. In addition, the TLC271 offers a bias-select mode that allows the user to select the best combination of power dissipation and ac performance for a particular application. These devices use Texas Instruments silicon-gate LinCMOS™ technology, which provides offset voltage stability far exceeding the stability available with conventional metal-gate processes.

AVAILABLE OPTIONS

| T _A | V _{IOmax} AT 25°C | PACKAGE | | | |
|----------------------|-------------------------------|------------------------------------|-------------------------|------------------------|------------------------------------|
| | | SMALL OUTLINE (D) | CHIP CARRIER (FK) | CERAMIC DIP (JG) | PLASTIC DIP (P) |
| 0°C to 70°C | 2 mV 5 mV 10 mV | TLC271BCD TLC271ACD TLC271CD | — | — | TLC271BCP TLC271ACP TLC271CP |
| –40°C to 85°C | 2 mV 5 mV 10 mV | TLC271BID TLC271AID TLC271ID | — | — | TLC271BIP TLC271AIP TLC271IP |
| –55°C to 125°C | 10 mV | TLC271MD | TLC271MFK | TLC271MJG | TLC271MP |

The D package is available taped and reeled. Add R suffix to the device type (e.g., TLC271BCDR).



Please be aware that an important notice concerning availability, standard warranty, and use in critical applications of Texas Instruments semiconductor products and disclaimers thereto appears at the end of this data sheet.

LinCMOS is a trademark of Texas Instruments Incorporated.

PRODUCTION DATA information is current as of publication date. Products conform to specifications per the terms of Texas Instruments standard warranty. Production processing does not necessarily include testing of all parameters.



Copyright © 1997, Texas Instruments Incorporated

TLC271, TLC271A, TLC271B
LinCMOS™ PROGRAMMABLE LOW-POWER
OPERATIONAL AMPLIFIERS

SLOS090C – NOVEMBER 1987 – REVISED AUGUST 1997

8DEVICE FEATURES

| PARAMETER† | BIAS-SELECT MODE | | | UNIT |
|-----------------------|------------------|--------|------|--------|
| | HIGH | MEDIUM | LOW | |
| P_D | 3375 | 525 | 50 | μW |
| SR | 3.6 | 0.4 | 0.03 | V/μs |
| V_n | 25 | 32 | 68 | nV/√Hz |
| B₁ | 1.7 | 0.5 | 0.09 | MHz |
| A_{VD} | 23 | 170 | 480 | V/mV |

† Typical at V_{DD} = 5 V, T_A = 25°C

description (continued)

Using the bias-select option, these cost-effective devices can be programmed to span a wide range of applications that previously required BiFET, NFET or bipolar technology. Three offset voltage grades are available (C-suffix and I-suffix types), ranging from the low-cost TLC271 (10 mV) to the TLC271B (2 mV) low-offset version. The extremely high input impedance and low bias currents, in conjunction with good common-mode rejection and supply voltage rejection, make these devices a good choice for new state-of-the-art designs as well as for upgrading existing designs.

In general, many features associated with bipolar technology are available in LinCMOS™ operational amplifiers, without the power penalties of bipolar technology. General applications such as transducer interfacing, analog calculations, amplifier blocks, active filters, and signal buffering are all easily designed with the TLC271. The devices also exhibit low-voltage single-supply operation, making them ideally suited for remote and inaccessible battery-powered applications. The common-mode input voltage range includes the negative rail.

A wide range of packaging options is available, including small-outline and chip-carrier versions for high-density system applications.

The device inputs and output are designed to withstand –100-mA surge currents without sustaining latch-up.

The TLC271 incorporates internal ESD-protection circuits that prevent functional failures at voltages up to 2000 V as tested under MIL-STD-883C, Method 3015.2; however, care should be exercised in handling these devices as exposure to ESD may result in the degradation of the device parametric performance.

The C-suffix devices are characterized for operation from 0°C to 70°C. The I-suffix devices are characterized for operation from –40°C to 85°C. The M-suffix devices are characterized for operation over the full military temperature range of –55°C to 125°C.

bias-select feature

The TLC271 offers a bias-select feature that allows the user to select any one of three bias levels depending on the level of performance desired. The tradeoffs between bias levels involve ac performance and power dissipation (see Table 1).



bias-select feature (continued)

Table 1. Effect of Bias Selection on Performance

| TYPICAL PARAMETER VALUES $T_A = 25^\circ\text{C}, V_{DD} = 5\text{ V}$ | | MODE | | | UNIT |
|---|--|--|---|--------------------------------------|------------------------|
| | | HIGH BIAS $R_L = 10\text{ k}\Omega$ | MEDIUM BIAS $R_L = 100\text{ k}\Omega$ | LOW BIAS $R_L = 1\text{ M}\Omega$ | |
| P_D | Power dissipation | 3.4 | 0.5 | 0.05 | mW |
| SR | Slew rate | 3.6 | 0.4 | 0.03 | V/ μs |
| V_n | Equivalent input noise voltage at $f = 1\text{ kHz}$ | 25 | 32 | 68 | nV/ $\sqrt{\text{Hz}}$ |
| B_1 | Unity-gain bandwidth | 1.7 | 0.5 | 0.09 | MHz |
| ϕ_m | Phase margin | 46° | 40° | 34° | |
| A_{VD} | Large-signal differential voltage amplification | 23 | 170 | 480 | V/mV |

bias selection

Bias selection is achieved by connecting the bias select pin to one of three voltage levels (see Figure 1). For medium-bias applications, it is recommended that the bias select pin be connected to the midpoint between the supply rails. This procedure is simple in split-supply applications, since this point is ground. In single-supply applications, the medium-bias mode necessitates using a voltage divider as indicated in Figure 1. The use of large-value resistors in the voltage divider reduces the current drain of the divider from the supply line. However, large-value resistors used in conjunction with a large-value capacitor require significant time to charge up to the supply midpoint after the supply is switched on. A voltage other than the midpoint can be used if it is within the voltages specified in Figure 1.

bias selection (continued)

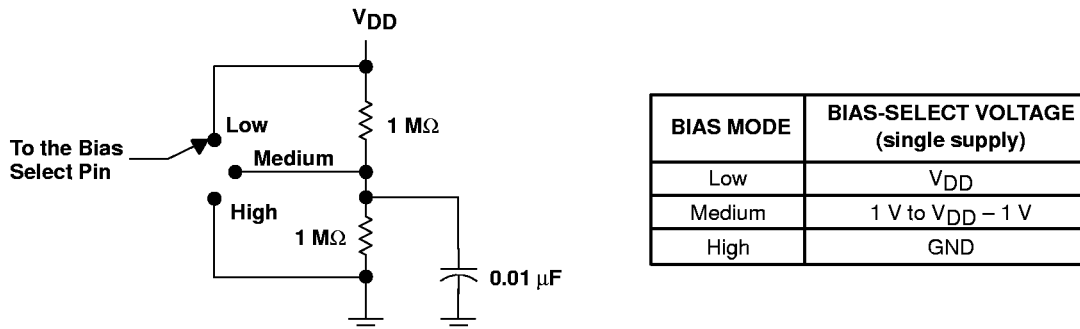

Figure 1. Bias Selection for Single-Supply Applications

high-bias mode

In the high-bias mode, the TLC271 series features low offset voltage drift, high input impedance, and low noise. Speed in this mode approaches that of BiFET devices but at only a fraction of the power dissipation. Unity-gain bandwidth is typically greater than 1 MHz.

medium-bias mode

The TLC271 in the medium-bias mode features low offset voltage drift, high input impedance, and low noise. Speed in this mode is similar to general-purpose bipolar devices but power dissipation is only a fraction of that consumed by bipolar devices.

TLC271, TLC271A, TLC271B LinCMOS™ PROGRAMMABLE LOW-POWER OPERATIONAL AMPLIFIERS

SLOS090C – NOVEMBER 1987 – REVISED AUGUST 1997

low-bias mode

In the low-bias mode, the TLC271 features low offset voltage drift, high input impedance, extremely low power consumption, and high differential voltage gain.

ORDER OF CONTENTS

| TOPIC | BIAS MODE |
|--|-----------------------------|
| schematic | all |
| absolute maximum ratings | all |
| recommended operating conditions | all |
| electrical characteristics operating characteristics typical characteristics | high (Figures 2 – 33) |
| electrical characteristics operating characteristics typical characteristics | medium (Figures 34 – 65) |
| electrical characteristics operating characteristics typical characteristics | low (Figures 66 – 97) |
| parameter measurement information | all |
| application information | all |

equivalent schematic

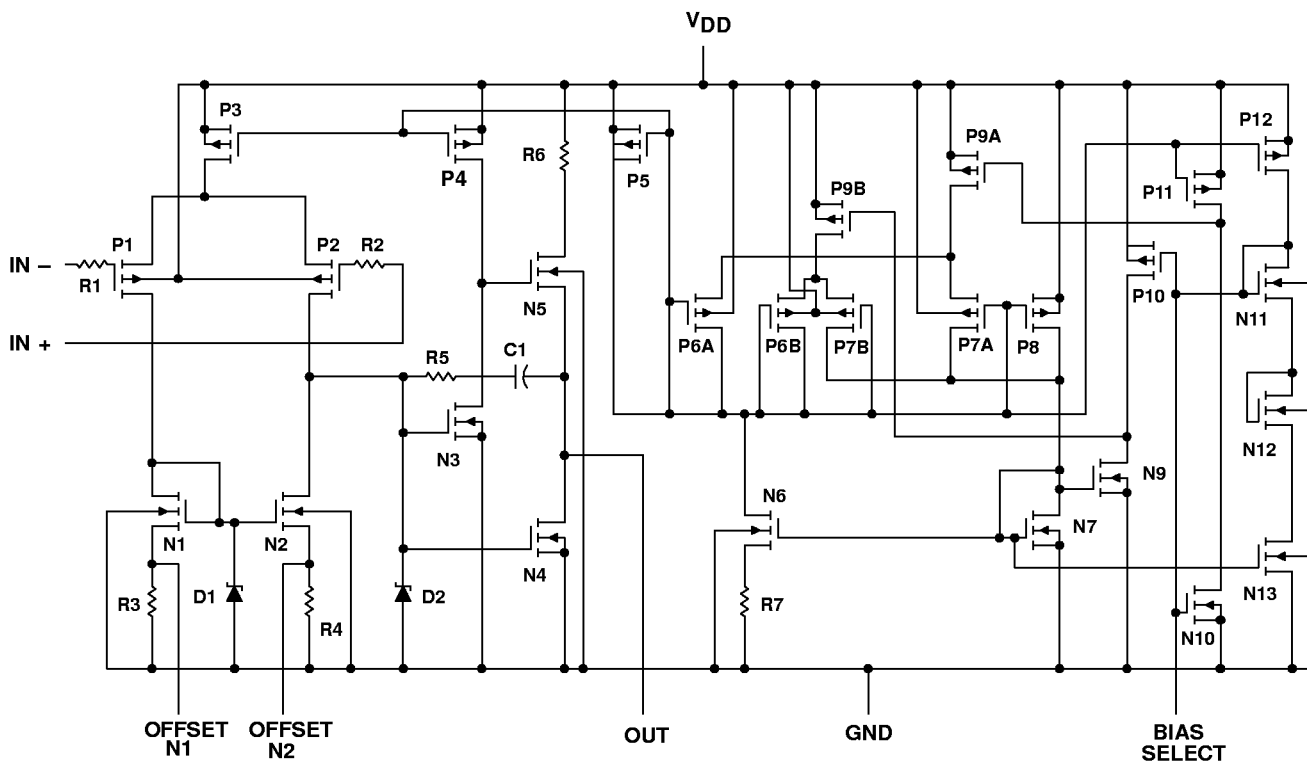

absolute maximum ratings over operating free-air temperature (unless otherwise noted)†

| | |
|--|------------------------------|
| Supply voltage, V_{DD} (see Note 1) | 18 V |
| Differential input voltage, V_{ID} (see Note 2) | $\pm V_{DD}$ |
| Input voltage range, V_I (any input) | – 0.3 V to V_{DD} |
| Input current, I_I | ± 5 mA |
| Output current, I_O | ± 30 mA |
| Duration of short-circuit current at (or below) 25°C (see Note 3) | Unlimited |
| Continuous total dissipation | See Dissipation Rating Table |
| Operating free-air temperature, T_A : C suffix | 0°C to 70°C |
| I suffix | – 40°C to 85°C |
| M suffix | – 55°C to 125°C |
| Storage temperature range | – 65°C to 150°C |
| Case temperature for 60 seconds: FK package | 260°C |
| Lead temperature 1,6 mm (1/16 inch) from case for 10 seconds: D or P package | 260°C |
| Lead temperature 1,6 mm (1/16 inch) from case for 60 seconds: JG package | 300°C |

† Stresses beyond those listed under “absolute maximum ratings” may cause permanent damage to the device. These are stress ratings only, and functional operation of the device at these or any other conditions beyond those indicated under “recommended operating conditions” is not implied. Exposure to absolute-maximum-rated conditions for extended periods may affect device reliability.

- NOTES: 1. All voltage values, except differential voltages, are with respect to network ground.
 2. Differential voltages are at $IN+$ with respect to $IN-$.
 3. The output may be shorted to either supply. Temperature and/or supply voltages must be limited to ensure that the maximum dissipation rating is not exceeded (see application section).

DISSIPATION RATING TABLE

| PACKAGE | $T_A \leq 25^\circ\text{C}$ | DERATING FACTOR | $T_A = 70^\circ\text{C}$ | $T_A = 85^\circ\text{C}$ | $T_A = 125^\circ\text{C}$ |
|---------|-----------------------------|--------------------------------|--------------------------|--------------------------|---------------------------|
| | POWER RATING | ABOVE $T_A = 25^\circ\text{C}$ | POWER RATING | POWER RATING | POWER RATING |
| D | 725 mW | 5.8 mW/°C | 464 mW | 377 mW | 145 mW |
| FK | 1375 mW | 11.0 mW/°C | 880 mW | 715 mW | 275 mW |
| JG | 1050 mW | 8.4 mW/°C | 672 mW | 546 mW | 210 mW |
| P | 1000 mW | 8.0 mW/°C | 640 mW | 520 mW | 200 mW |

recommended operating conditions

| | | C SUFFIX | | I SUFFIX | | M SUFFIX | | UNIT |
|---------------------------------------|-----------------|----------|-----|----------|-----|----------|-----|------|
| | | MIN | MAX | MIN | MAX | MIN | MAX | |
| Supply voltage, V_{DD} | | 3 | 16 | 4 | 16 | 5 | 16 | V |
| Common-mode input voltage, V_{IC} | $V_{DD} = 5$ V | –0.2 | 3.5 | –0.2 | 3.5 | 0 | 3.5 | V |
| | $V_{DD} = 10$ V | –0.2 | 8.5 | –0.2 | 8.5 | 0 | 8.5 | |
| Operating free-air temperature, T_A | | 0 | 70 | –40 | 85 | –55 | 125 | °C |

TLC271, TLC271A, TLC271B
LinCMOS™ PROGRAMMABLE LOW-POWER
OPERATIONAL AMPLIFIERS

SLOS090C – NOVEMBER 1987 – REVISED AUGUST 1997

HIGH-BIAS MODE

electrical characteristics at specified free-air temperature (unless otherwise noted)

| PARAMETER | | TEST CONDITIONS | T _A † | TLC271C, TLC271AC, TLC271BC | | | | | | UNIT |
|---------------------|--|---|------------------|-----------------------------|-------------|-----|------------------------|-------------|-------|------|
| | | | | V _{DD} = 5 V | | | V _{DD} = 10 V | | | |
| | | | | MIN | TYP | MAX | MIN | TYP | MAX | |
| V _{IO} | Input offset voltage | V _O = 1.4 V, V _{IC} = 0 V, R _S = 50 Ω, R _L = 10 kΩ | 25°C | 1.1 | | 10 | 1.1 | | 10 | mV |
| | | | Full range | | | 12 | | | 12 | |
| | | | 25°C | 0.9 | | 5 | 0.9 | | 5 | |
| | | | Full range | | | 6.5 | | | 6.5 | |
| | | | 25°C | 0.34 | | 2 | 0.39 | | 2 | |
| | | | Full range | | | 3 | | | 3 | |
| α _{VIO} | Average temperature coefficient of input offset voltage | | 25°C to 70°C | 1.8 | | | 2 | | μV/°C | |
| I _{IO} | Input offset current (see Note 4) | V _O = V _{DD} /2, V _{IC} = V _{DD} /2 | 25°C | 0.1 | | | 0.1 | | pA | |
| | | | 70°C | 7 | | 300 | 7 | | | 300 |
| I _{IB} | Input bias current (see Note 4) | V _O = V _{DD} /2, V _{IC} = V _{DD} /2 | 25°C | 0.6 | | | 0.7 | | pA | |
| | | | 70°C | 40 | | 600 | 50 | | | 600 |
| V _{ICR} | Common-mode input voltage range (see Note 5) | | 25°C | -0.2 to 4 | -0.3 to 4.2 | | -0.2 to 9 | -0.3 to 9.2 | V | |
| | | | Full range | -0.2 to 3.5 | | | -0.2 to 8.5 | | V | |
| V _{OH} | High-level output voltage | V _{ID} = 100 mV, R _L = 10 kΩ | 25°C | 3.2 | 3.8 | | 8 | 8.5 | V | |
| | | | 0°C | 3 | 3.8 | | 7.8 | 8.5 | | |
| | | | 70°C | 3 | 3.8 | | 7.8 | 8.4 | | |
| V _{OL} | Low-level output voltage | V _{ID} = -100 mV, I _{OL} = 0 | 25°C | 0 | | 50 | 0 | | 50 | mV |
| | | | 0°C | 0 | | 50 | 0 | | 50 | |
| | | | 70°C | 0 | | 50 | 0 | | 50 | |
| A _{VD} | Large-signal differential voltage amplification | R _L = 10 kΩ, See Note 6 | 25°C | 5 | 23 | | 10 | 36 | V/mV | |
| | | | 0°C | 4 | 27 | | 7.5 | 42 | | |
| | | | 70°C | 4 | 20 | | 7.5 | 32 | | |
| CMRR | Common-mode rejection ratio | V _{IC} = V _{ICRmin} | 25°C | 65 | 80 | | 65 | 85 | dB | |
| | | | 0°C | 60 | 84 | | 60 | 88 | | |
| | | | 70°C | 60 | 85 | | 60 | 88 | | |
| k _{SVR} | Supply-voltage rejection ratio (ΔV _{DD} /ΔV _{IO}) | V _{DD} = 5 V to 10 V V _O = 1.4 V | 25°C | 65 | 95 | | 65 | 95 | dB | |
| | | | 0°C | 60 | 94 | | 60 | 94 | | |
| | | | 70°C | 60 | 96 | | 60 | 96 | | |
| I _{I(SEL)} | Input current (BIAS SELECT) | V _{I(SEL)} = 0 | 25°C | -1.4 | | | -1.9 | | μA | |
| I _{DD} | Supply current | V _O = V _{DD} /2, V _{IC} = V _{DD} /2, No load | 25°C | 675 | 1600 | | 950 | 2000 | μA | |
| | | | 0°C | 775 | 1800 | | 1125 | 2200 | | |
| | | | 70°C | 575 | 1300 | | 750 | 1700 | | |

† Full range is 0°C to 70°C.

- NOTES: 4. The typical values of input bias current and input offset current below 5 pA were determined mathematically.
5. This range also applies to each input individually.
6. At V_{DD} = 5 V, V_O = 0.25 V to 2 V; at V_{DD} = 10 V, V_O = 1 V to 6 V.



HIGH-BIAS MODE

electrical characteristics at specified free-air temperature (unless otherwise noted)

| PARAMETER | | TEST CONDITIONS | T _A † | TLC271I, TLC271AI, TLC271BI | | | | | | UNIT |
|---------------------|--|---|------------------|-----------------------------------|--|-----------|------------------------|------|-------|------|
| | | | | V _{DD} = 5 V | | | V _{DD} = 10 V | | | |
| | | | | MIN | TYP | MAX | MIN | TYP | MAX | |
| V _{IO} | Input offset voltage | V _O = 1.4 V, V _{IC} = 0 V, R _S = 50 Ω, R _L = 10 kΩ | 25°C | 1.1 | | 10 | 1.1 | | 10 | mV |
| | | | Full range | | | | 13 | | | |
| | | | 25°C | 0.9 | | 5 | 0.9 | | 5 | |
| | | | Full range | | | | 7 | | | |
| α _{VIO} | Average temperature coefficient of input offset voltage | | 25°C to 85°C | 1.8 | | 2 | | | μV/°C | |
| | | | I _{IO} | Input offset current (see Note 4) | V _O = V _{DD} /2, V _{IC} = V _{DD} /2 | 25°C | 0.1 | | 0.1 | |
| I _{IB} | Input bias current (see Note 4) | V _O = V _{DD} /2, V _{IC} = V _{DD} /2 | 25°C | 0.6 | | 0.7 | | | pA | |
| | | | 85°C | 200 | 2000 | 220 | 2000 | | | |
| V _{ICR} | Common-mode input voltage range (see Note 5) | | 25°C | -0.2 to 4 | -0.3 to 4.2 | -0.2 to 9 | -0.3 to 9.2 | V | | |
| | | | Full range | -0.2 to 3.5 | -0.2 to 8.5 | V | | | | |
| V _{OH} | High-level output voltage | V _{ID} = 100 mV, R _L = 10 kΩ | 25°C | 3.2 | 3.8 | 8 | 8.5 | V | | |
| | | | -40°C | 3 | 3.8 | 7.8 | 8.5 | | | |
| | | | 85°C | 3 | 3.8 | 7.8 | 8.5 | | | |
| V _{OL} | Low-level output voltage | V _{ID} = -100 mV, I _{OL} = 0 | 25°C | 0 | | 50 | 0 | | 50 | mV |
| | | | -40°C | 0 | | 50 | 0 | | 50 | |
| | | | 85°C | 0 | | 50 | 0 | | 50 | |
| A _{VD} | Large-signal differential voltage amplification | R _L = 10 kΩ, See Note 6 | 25°C | 5 | 23 | 10 | 36 | V/mV | | |
| | | | -40°C | 3.5 | 32 | 7 | 46 | | | |
| | | | 85°C | 3.5 | 19 | 7 | 31 | | | |
| CMRR | Common-mode rejection ratio | V _{IC} = V _{ICRmin} | 25°C | 65 | 80 | 65 | 85 | dB | | |
| | | | -40°C | 60 | 81 | 60 | 87 | | | |
| | | | 85°C | 60 | 86 | 60 | 88 | | | |
| k _{SVR} | Supply-voltage rejection ratio (ΔV _{DD} /ΔV _{IO}) | V _{DD} = 5 V to 10 V V _O = 1.4 V | 25°C | 65 | 95 | 65 | 95 | dB | | |
| | | | -40°C | 60 | 92 | 60 | 92 | | | |
| | | | 85°C | 60 | 96 | 60 | 96 | | | |
| I _{I(SEL)} | Input current (BIAS SELECT) | V _{I(SEL)} = 0 | 25°C | -1.4 | | -1.9 | | | μA | |
| I _{DD} | Supply current | V _O = V _{DD} /2, V _{IC} = V _{DD} /2, No load | 25°C | 675 | 1600 | 950 | 2000 | μA | | |
| | | | -40°C | 950 | 2200 | 1375 | 2500 | | | |
| | | | 85°C | 525 | 1200 | 725 | 1600 | | | |

† Full range is -40°C to 85°C.

- NOTES:
4. The typical values of input bias current and input offset current below 5 pA were determined mathematically.
 5. This range also applies to each input individually.
 6. At V_{DD} = 5 V, V_O = 0.25 V to 2 V; at V_{DD} = 10 V, V_O = 1 V to 6 V.

TLC271, TLC271A, TLC271B
LinCMOS™ PROGRAMMABLE LOW-POWER
OPERATIONAL AMPLIFIERS

SLOS090C – NOVEMBER 1987 – REVISED AUGUST 1997

HIGH-BIAS MODE

electrical characteristics at specified free-air temperature (unless otherwise noted)

| PARAMETER | TEST CONDITIONS | T _A † | TLC271M | | | | | | UNIT |
|---|---|------------------|-----------------------|-------------|-----|------------------------|-------------|-----|-------|
| | | | V _{DD} = 5 V | | | V _{DD} = 10 V | | | |
| | | | MIN | TYP | MAX | MIN | TYP | MAX | |
| V _{IO} Input offset voltage | V _O = 1.4 V, V _{IC} = 0 V, R _S = 50 Ω, R _L = 10 kΩ | 25°C | 1.1 | | 10 | 1.1 | | 10 | mV |
| | | Full range | | | 12 | | | 12 | |
| α _{VIO} Average temperature coefficient of input offset voltage | | 25°C to 125°C | 2.1 | | | 2.2 | | | μV/°C |
| I _{IO} Input offset current (see Note 4) | V _O = V _{DD} /2, V _{IC} = V _{DD} /2 | 25°C | 0.1 | | | 0.1 | | | pA |
| | | 125°C | 1.4 | 15 | 1.8 | 15 | | | nA |
| I _{IB} Input bias current (see Note 4) | V _O = V _{DD} /2, V _{IC} = V _{DD} /2 | 25°C | 0.6 | | | 0.7 | | | pA |
| | | 125°C | 9 | 35 | 10 | 35 | | | nA |
| V _{ICR} Common-mode input voltage range (see Note 5) | | 25°C | 0 to 4 | -0.3 to 4.2 | | 0 to 9 | -0.3 to 9.2 | | V |
| | | Full range | 0 to 3.5 | | | 0 to 8.5 | | | V |
| V _{OH} High-level output voltage | V _{ID} = 100 mV, R _L = 10 kΩ | 25°C | 3.2 | 3.8 | | 8 | 8.5 | | V |
| | | -55°C | 3 | 3.8 | | 7.8 | 8.5 | | |
| | | 125°C | 3 | 3.8 | | 7.8 | 8.4 | | |
| V _{OL} Low-level output voltage | V _{ID} = -100 mV, I _{OL} = 0 | 25°C | | 0 | 50 | | 0 | 50 | mV |
| | | -55°C | | 0 | 50 | | 0 | 50 | |
| | | 125°C | | 0 | 50 | | 0 | 50 | |
| A _{VD} Large-signal differential voltage amplification | R _L = 10 kΩ, See Note 6 | 25°C | 5 | 23 | | 10 | 36 | | V/mV |
| | | -55°C | 3.5 | 35 | | 7 | 50 | | |
| | | 125°C | 3.5 | 16 | | 7 | 27 | | |
| CMRR Common-mode rejection ratio | V _{IC} = V _{ICRmin} | 25°C | 65 | 80 | | 65 | 85 | | dB |
| | | -55°C | 60 | 81 | | 60 | 87 | | |
| | | 125°C | 60 | 84 | | 60 | 86 | | |
| k _{SVR} Supply-voltage rejection ratio (ΔV _{DD} /ΔV _{IO}) | V _{DD} = 5 V to 10 V V _O = 1.4 V | 25°C | 65 | 95 | | 65 | 95 | | dB |
| | | -55°C | 60 | 90 | | 60 | 90 | | |
| | | 125°C | 60 | 97 | | 60 | 97 | | |
| I _{I(SEL)} Input current (BIAS SELECT) | V _{I(SEL)} = 0 | 25°C | -1.4 | | | -1.9 | | | μA |
| I _{DD} Supply current | V _O = V _{DD} /2, V _{IC} = V _{DD} /2, No load | 25°C | 675 | 1600 | | 950 | 2000 | | μA |
| | | -55°C | 1000 | 2500 | | 1475 | 3000 | | |
| | | 125°C | 475 | 1100 | | 625 | 1400 | | |

† Full range is -55°C to 125°C.

NOTES: 4. The typical values of input bias current and input offset current below 5 pA were determined mathematically.

5. This range also applies to each input individually.

6. At V_{DD} = 5 V, V_O = 0.25 V to 2 V; at V_{DD} = 10 V, V_O = 1 V to 6 V.



HIGH-BIAS MODE

operating characteristics at specified free-air temperature, $V_{DD} = 5\text{ V}$

| PARAMETER | TEST CONDITIONS | T_A | TLC271C, TLC271AC, TLC271BC | | | UNIT |
|---|--|--------------------------------|-----------------------------|-----|------------------------|------------|
| | | | MIN | TYP | MAX | |
| SR Slew rate at unity gain | $R_L = 10\text{ k}\Omega$, $C_L = 20\text{ pF}$, See Figure 98 | $V_{I(PP)} = 1\text{ V}$ | 25°C | 3.6 | | V/ μ s |
| | | | 0°C | 4 | | |
| | | | 70°C | 3 | | |
| | | $V_{I(PP)} = 2.5\text{ V}$ | 25°C | 2.9 | | |
| | | | 0°C | 3.1 | | |
| | | | 70°C | 2.5 | | |
| V_n Equivalent input noise voltage | $f = 1\text{ kHz}$, See Figure 99 | $R_S = 20\ \Omega$, 25°C | 25 | | nV/ $\sqrt{\text{Hz}}$ | |
| B_{OM} Maximum output-swing bandwidth | $V_O = V_{OH}$, $R_L = 10\text{ k}\Omega$, $C_L = 20\text{ pF}$, See Figure 98 | 25°C | 320 | | kHz | |
| | | 0°C | 340 | | | |
| | | 70°C | 260 | | | |
| B_1 Unity-gain bandwidth | $V_I = 10\text{ mV}$, See Figure 100 | $C_L = 20\text{ pF}$, 25°C | 1.7 | | MHz | |
| | | | 0°C | 2 | | |
| | | | 70°C | 1.3 | | |
| ϕ_m Phase margin | $V_I = 10\text{ mV}$, $C_L = 20\text{ pF}$, $f = B_1$, See Figure 100 | 25°C | 46° | | | |
| | | 0°C | 47° | | | |
| | | 70°C | 44° | | | |

operating characteristics at specified free-air temperature, $V_{DD} = 10\text{ V}$

| PARAMETER | TEST CONDITIONS | T_A | TLC271C, TLC271AC, TLC271BC | | | UNIT |
|---|--|--------------------------------|-----------------------------|-----|------------------------|------------|
| | | | MIN | TYP | MAX | |
| SR Slew rate at unity gain | $R_L = 10\text{ k}\Omega$, $C_L = 20\text{ pF}$, See Figure 98 | $V_{I(PP)} = 1\text{ V}$ | 25°C | 5.3 | | V/ μ s |
| | | | 0°C | 5.9 | | |
| | | | 70°C | 4.3 | | |
| | | $V_{I(PP)} = 5.5\text{ V}$ | 25°C | 4.6 | | |
| | | | 0°C | 5.1 | | |
| | | | 70°C | 3.8 | | |
| V_n Equivalent input noise voltage | $f = 1\text{ kHz}$, See Figure 99 | $R_S = 20\ \Omega$, 25°C | 25 | | nV/ $\sqrt{\text{Hz}}$ | |
| B_{OM} Maximum output-swing bandwidth | $V_O = V_{OH}$, $R_L = 10\text{ k}\Omega$, $C_L = 20\text{ pF}$, See Figure 98 | 25°C | 200 | | kHz | |
| | | 0°C | 220 | | | |
| | | 70°C | 140 | | | |
| B_1 Unity-gain bandwidth | $V_I = 10\text{ mV}$, See Figure 100 | $C_L = 20\text{ pF}$, 25°C | 2.2 | | MHz | |
| | | | 0°C | 2.5 | | |
| | | | 70°C | 1.8 | | |
| ϕ_m Phase margin | $f = B_1$, $C_L = 20\text{ pF}$, $V_I = 10\text{ mV}$, See Figure 100 | 25°C | 49° | | | |
| | | 0°C | 50° | | | |
| | | 70°C | 46° | | | |

TLC271, TLC271A, TLC271B
LinCMOS™ PROGRAMMABLE LOW-POWER
OPERATIONAL AMPLIFIERS

SLOS090C – NOVEMBER 1987 – REVISED AUGUST 1997

HIGH-BIAS MODE

operating characteristics at specified free-air temperature, $V_{DD} = 5\text{ V}$

| PARAMETER | TEST CONDITIONS | T_A | TLC271I, TLC271AI, TLC271BI | | | UNIT |
|---|--|--------------------------------|--------------------------------|-----|------------------------|------------|
| | | | MIN | TYP | MAX | |
| SR Slew rate at unity gain | $R_L = 10\text{ k}\Omega$, $C_L = 20\text{ pF}$, See Figure 98 | $V_{I(PP)} = 1\text{ V}$ | 25°C | 3.6 | | V/ μ s |
| | | | -40°C | 4.5 | | |
| | | | 85°C | 2.8 | | |
| | | $V_{I(PP)} = 2.5\text{ V}$ | 25°C | 2.9 | | |
| | | | -40°C | 3.5 | | |
| | | | 85°C | 2.3 | | |
| V_n Equivalent input noise voltage | $f = 1\text{ kHz}$, See Figure 99 | $R_S = 20\ \Omega$, 25°C | 25 | | nV/ $\sqrt{\text{Hz}}$ | |
| B_{OM} Maximum output-swing bandwidth | $V_O = V_{OH}$, $R_L = 10\text{ k}\Omega$, $C_L = 20\text{ pF}$, See Figure 98 | 25°C | 320 | | kHz | |
| | | -40°C | 380 | | | |
| | | 85°C | 250 | | | |
| B_1 Unity-gain bandwidth | $V_I = 10\text{ mV}$, See Figure 100 | $C_L = 20\text{ pF}$, 25°C | 1.7 | | MHz | |
| | | | -40°C | 2.6 | | |
| | | | 85°C | 1.2 | | |
| ϕ_m Phase margin | $V_I = 10\text{ mV}$, $C_L = 20\text{ pF}$, $f = B_1$, See Figure 100 | 25°C | 46° | | | |
| | | -40°C | 49° | | | |
| | | 85°C | 43° | | | |

operating characteristics at specified free-air temperature, $V_{DD} = 10\text{ V}$

| PARAMETER | TEST CONDITIONS | T_A | TLC271I, TLC271AI, TLC271BI | | | UNIT |
|---|--|--------------------------------|--------------------------------|-----|------------------------|------------|
| | | | MIN | TYP | MAX | |
| SR Slew rate at unity gain | $R_L = 10\text{ k}\Omega$, $C_L = 20\text{ pF}$, See Figure 98 | $V_{I(PP)} = 1\text{ V}$ | 25°C | 5.3 | | V/ μ s |
| | | | -40°C | 6.8 | | |
| | | | 85°C | 4 | | |
| | | $V_{I(PP)} = 5.5\text{ V}$ | 25°C | 4.6 | | |
| | | | -40°C | 5.8 | | |
| | | | 85°C | 3.5 | | |
| V_n Equivalent input noise voltage | $f = 1\text{ kHz}$, See Figure 99 | $R_S = 20\ \Omega$, 25°C | 25 | | nV/ $\sqrt{\text{Hz}}$ | |
| B_{OM} Maximum output-swing bandwidth | $V_O = V_{OH}$, $R_L = 10\text{ k}\Omega$, $C_L = 20\text{ pF}$, See Figure 98 | 25°C | 200 | | kHz | |
| | | -40°C | 260 | | | |
| | | 85°C | 130 | | | |
| B_1 Unity-gain bandwidth | $V_I = 10\text{ mV}$, See Figure 100 | $C_L = 20\text{ pF}$, 25°C | 2.2 | | MHz | |
| | | | -40°C | 3.1 | | |
| | | | 85°C | 1.7 | | |
| ϕ_m Phase margin | $V_I = 10\text{ mV}$, $C_L = 20\text{ pF}$, $f = B_1$, See Figure 100 | 25°C | 49° | | | |
| | | -40°C | 52° | | | |
| | | 85°C | 46° | | | |



HIGH-BIAS MODE

operating characteristics at specified free-air temperature, $V_{DD} = 5\text{ V}$

| PARAMETER | TEST CONDITIONS | T _A | TLC271M | | | UNIT |
|--|---|--|---------|-----|--------|------|
| | | | MIN | TYP | MAX | |
| SR Slew rate at unity gain | R _L = 10 kΩ, C _L = 20 pF, See Figure 98 | V _{I(PP)} = 1 V | 25°C | 3.6 | | V/μs |
| | | | -55°C | 4.7 | | |
| | | | 125°C | 2.3 | | |
| | | V _{I(PP)} = 2.5 V | 25°C | 2.9 | | |
| | | | -55°C | 3.7 | | |
| | | | 125°C | 2 | | |
| V _n Equivalent input noise voltage | f = 1 kHz, See Figure 99 | R _S = 20 Ω, 25°C | 25 | | nV/√Hz | |
| B _{OM} Maximum output-swing bandwidth | V _O = V _{OH} , R _L = 10 kΩ, | C _L = 20 pF, See Figure 98 | 25°C | 320 | | kHz |
| | | | -55°C | 400 | | |
| | | | 125°C | 230 | | |
| B ₁ Unity-gain bandwidth | V _I = 10 mV, See Figure 100 | C _L = 20 pF, | 25°C | 1.7 | | MHz |
| | | | -55°C | 2.9 | | |
| | | | 125°C | 1.1 | | |
| φ _m Phase margin | V _I = 10 mV, C _L = 20 pF, | f = B ₁ , See Figure 100 | 25°C | 46° | | |
| | | | -55°C | 49° | | |
| | | | 125°C | 41° | | |

operating characteristics at specified free-air temperature, $V_{DD} = 10\text{ V}$

| PARAMETER | TEST CONDITIONS | T _A | TLC271M | | | UNIT |
|--|---|---|---------|-----|--------|------|
| | | | MIN | TYP | MAX | |
| SR Slew rate at unity gain | R _L = 10 kΩ, C _L = 20 pF, See Figure 98 | V _{I(PP)} = 1 V | 25°C | 5.3 | | V/μs |
| | | | -55°C | 7.1 | | |
| | | | 125°C | 3.1 | | |
| | | V _{I(PP)} = 5.5 V | 25°C | 4.6 | | |
| | | | -55°C | 6.1 | | |
| | | | 125°C | 2.7 | | |
| V _n Equivalent input noise voltage | f = 1 kHz, See Figure 99 | R _S = 20 Ω, 25°C | 25 | | nV/√Hz | |
| B _{OM} Maximum output-swing bandwidth | V _O = V _{OH} , R _L = 10 kΩ, | C _L = 20 pF, See Figure 98 | 25°C | 200 | | kHz |
| | | | -55°C | 280 | | |
| | | | 125°C | 110 | | |
| B ₁ Unity-gain bandwidth | V _I = 10 mV, See Figure 100 | C _L = 20 pF, | 25°C | 2.2 | | MHz |
| | | | -55°C | 3.4 | | |
| | | | 125°C | 1.6 | | |
| φ _m Phase margin | f = B ₁ , C _L = 20 pF, | V _I = 10 mV, See Figure 100 | 25°C | 49° | | |
| | | | -55°C | 52° | | |
| | | | 125°C | 44° | | |

TLC271, TLC271A, TLC271B
LinCMOS™ PROGRAMMABLE LOW-POWER
OPERATIONAL AMPLIFIERS

SLOS090C – NOVEMBER 1987 – REVISED AUGUST 1997

TYPICAL CHARACTERISTICS (HIGH-BIAS MODE)

Table of Graphs

| | | FIGURE | |
|----------------|---|-------------------------------|--------|
| V_{IO} | Input offset voltage | Distribution | 2, 3 |
| α_{VIO} | Temperature coefficient | Distribution | 4, 5 |
| V_{OH} | High-level output voltage | vs High-level output current | 6, 7 |
| | | vs Supply voltage | 8 |
| | | vs Free-air temperature | 9 |
| V_{OL} | Low-level output voltage | vs Common-mode input voltage | 10, 11 |
| | | vs Differential input voltage | 12 |
| | | vs Free-air temperature | 13 |
| | | vs Low-level output current | 14, 15 |
| A_{VD} | Large-signal differential voltage amplification | vs Supply voltage | 16 |
| | | vs Free-air temperature | 17 |
| | | vs Frequency | 28, 29 |
| I_{IB} | Input bias current | vs Free-air temperature | 18 |
| I_{IO} | Input offset current | vs Free-air temperature | 18 |
| V_{IC} | Common-mode input voltage | vs Supply voltage | 19 |
| I_{DD} | Supply current | vs Supply voltage | 20 |
| | | vs Free-air temperature | 21 |
| SR | Slew rate | vs Supply voltage | 22 |
| | | vs Free-air temperature | 23 |
| | Bias-select current | vs Supply voltage | 24 |
| $V_{O(PP)}$ | Maximum peak-to-peak output voltage | vs Frequency | 25 |
| B_1 | Unity-gain bandwidth | vs Free-air temperature | 26 |
| | | vs Supply voltage | 27 |
| A_{VD} | Large-signal differential voltage amplification | vs Frequency | 28, 29 |
| ϕ_m | Phase margin | vs Supply voltage | 30 |
| | | vs Free-air temperature | 31 |
| | | vs Capacitive load | 32 |
| V_n | Equivalent input noise voltage | vs Frequency | 33 |
| | | Phase shift | 28, 29 |



TYPICAL CHARACTERISTICS (HIGH-BIAS MODE)†

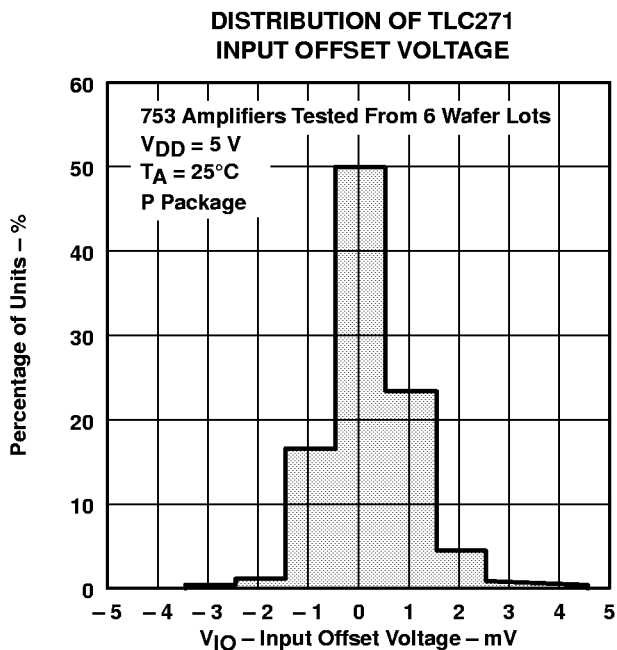

Figure 2

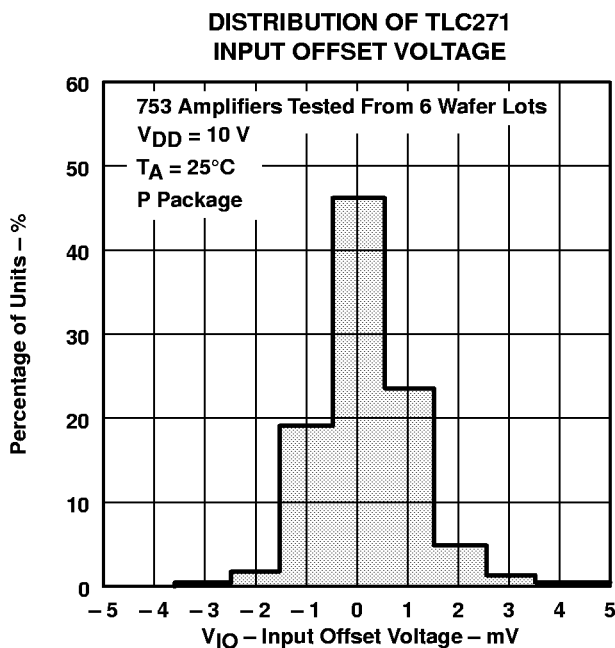

Figure 3

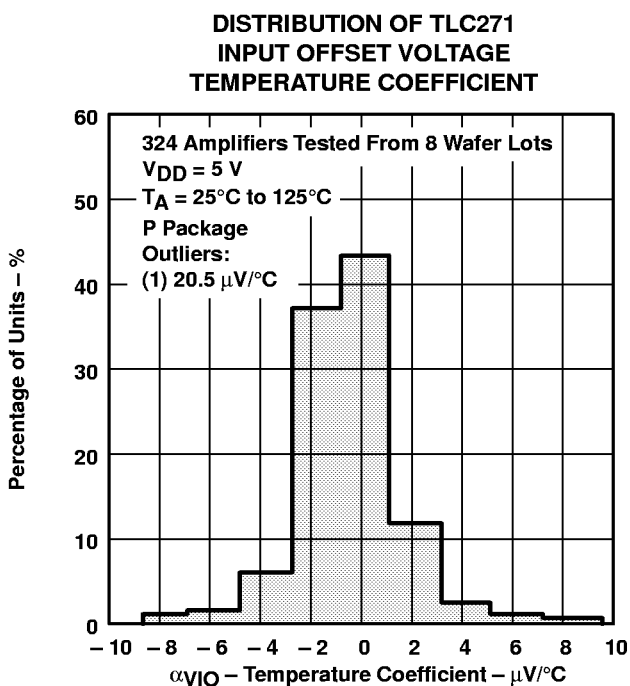

Figure 4

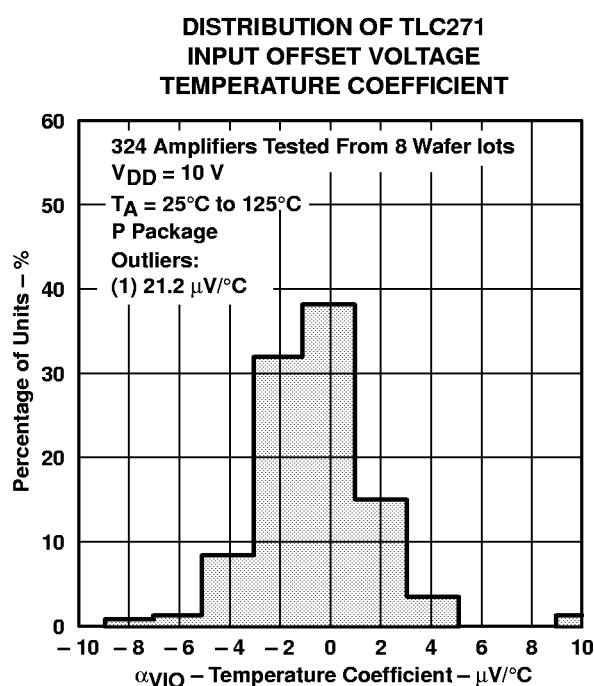

Figure 5

† Data at high and low temperatures are applicable only within the rated operating free-air temperature ranges of the various devices.

TYPICAL CHARACTERISTICS (HIGH-BIAS MODE)†

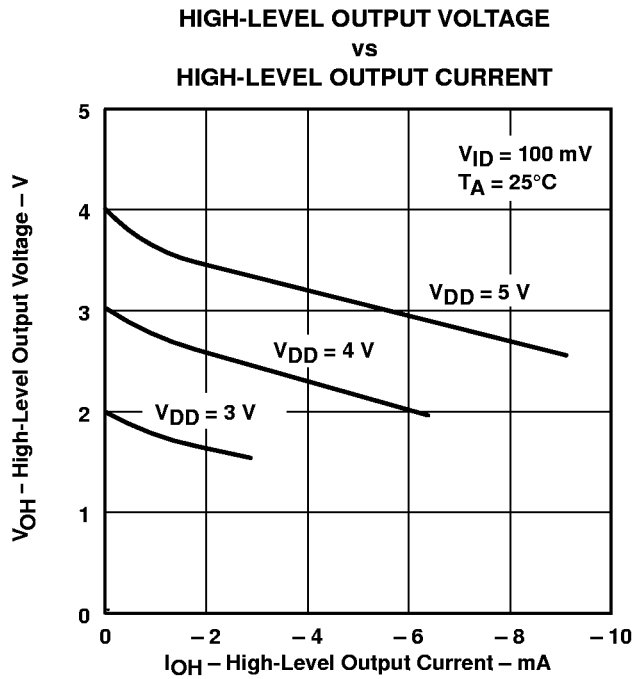

Figure 6

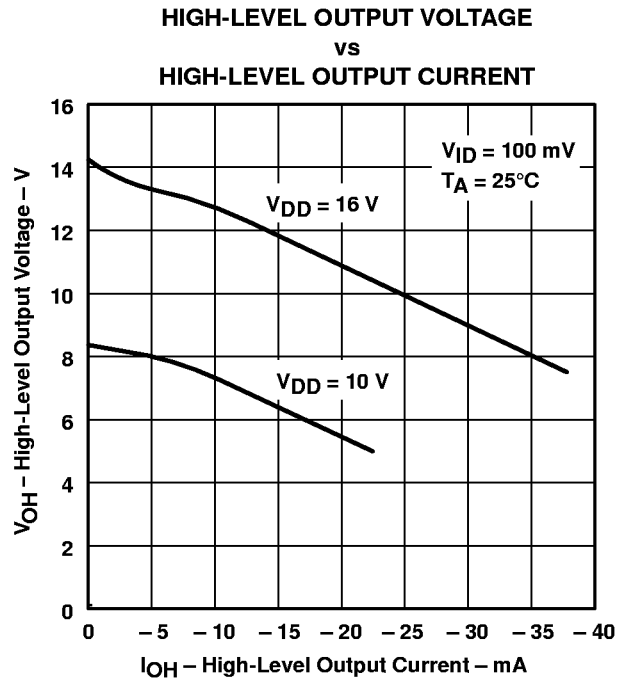

Figure 7

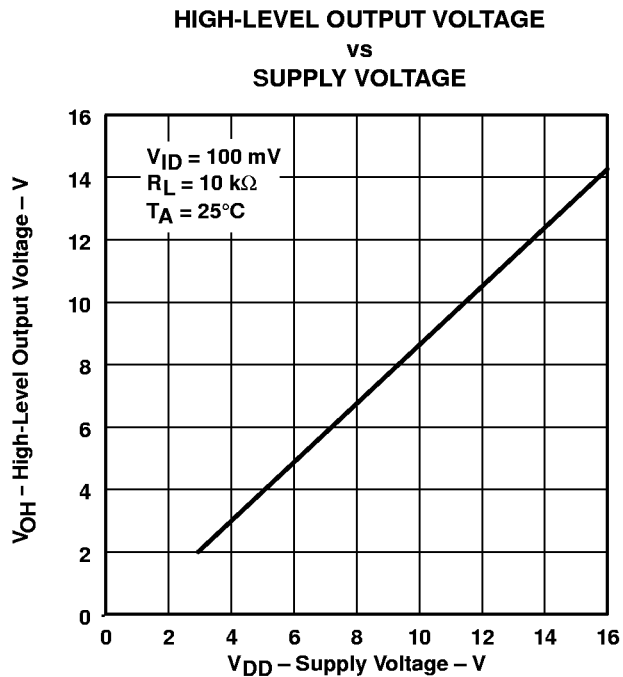

Figure 8

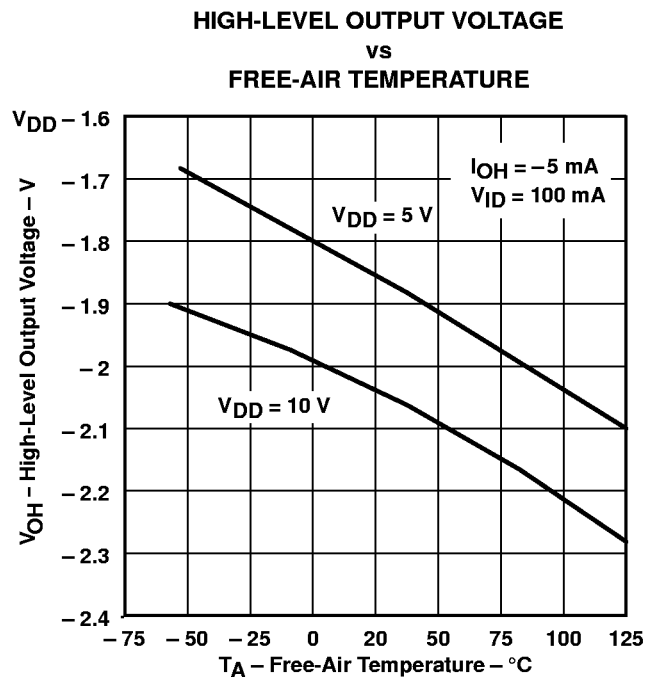

Figure 9

† Data at high and low temperatures are applicable only within the rated operating free-air temperature ranges of the various devices.

TYPICAL CHARACTERISTICS (HIGH-BIAS MODE)†

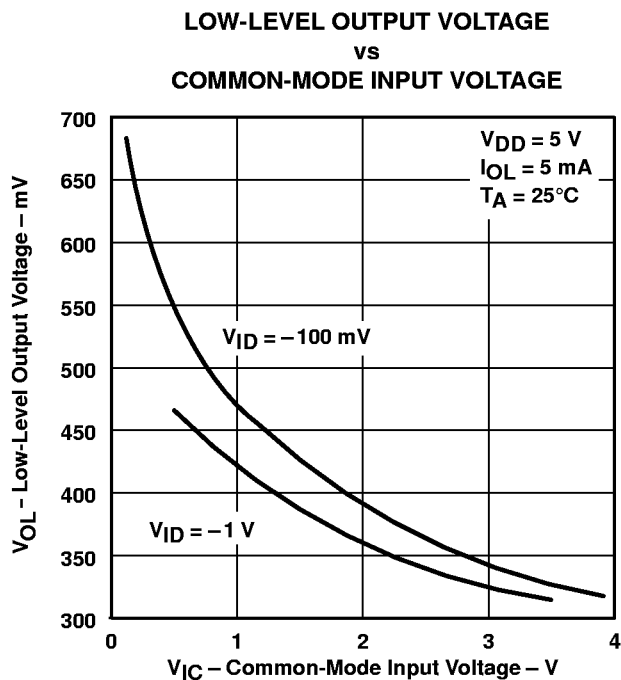

Figure 10

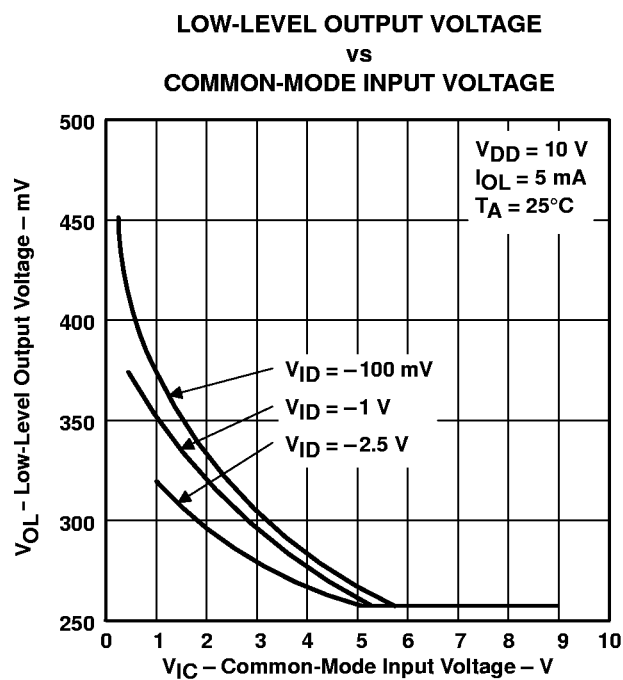

Figure 11

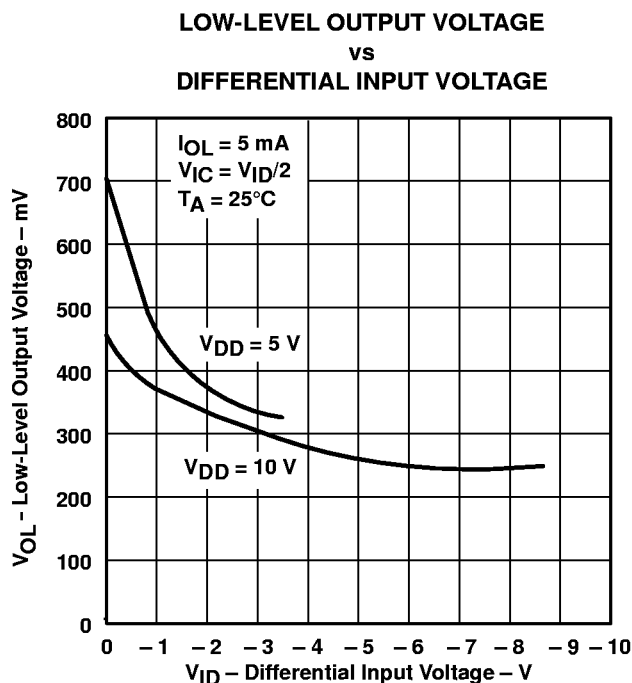

Figure 12

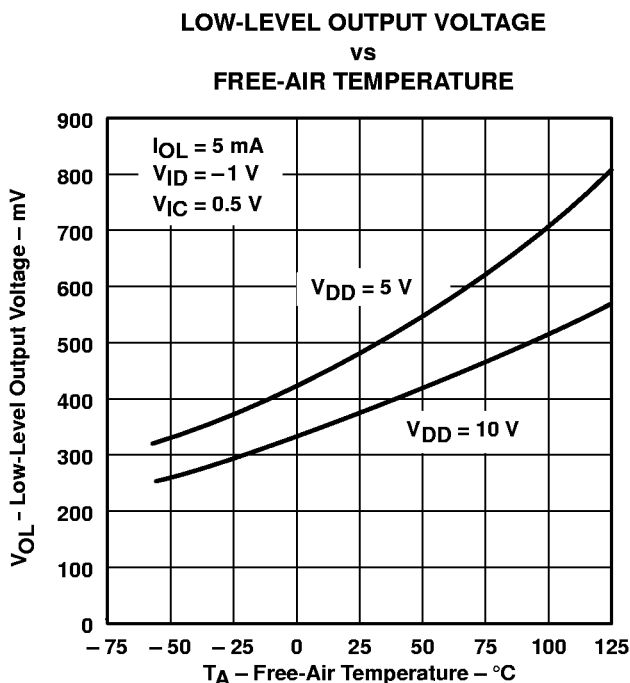

Figure 13

† Data at high and low temperatures are applicable only within the rated operating free-air temperature ranges of the various devices.

TYPICAL CHARACTERISTICS (HIGH-BIAS MODE)†

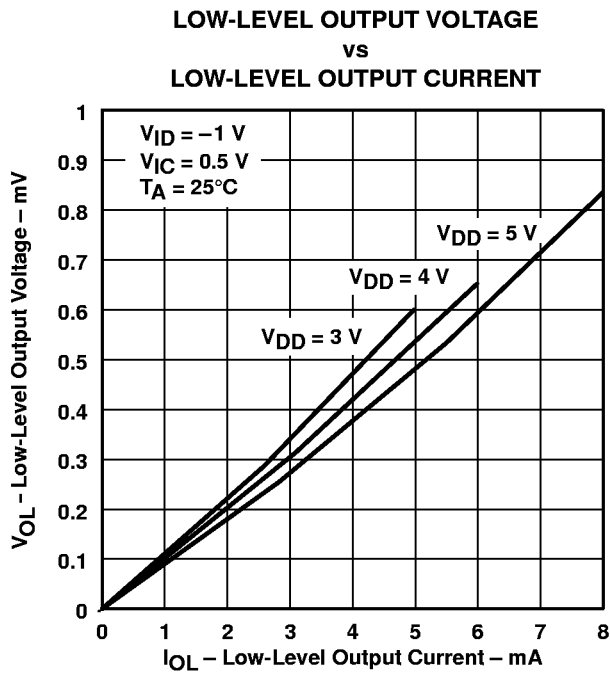

Figure 14

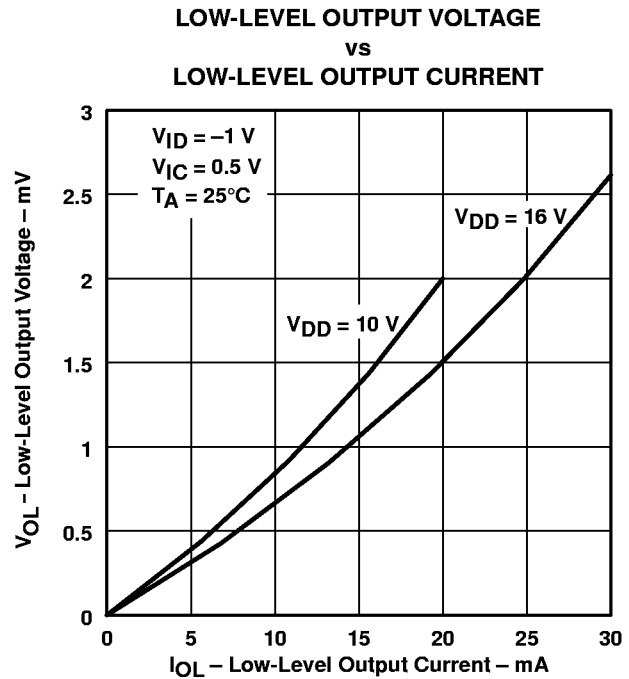

Figure 15

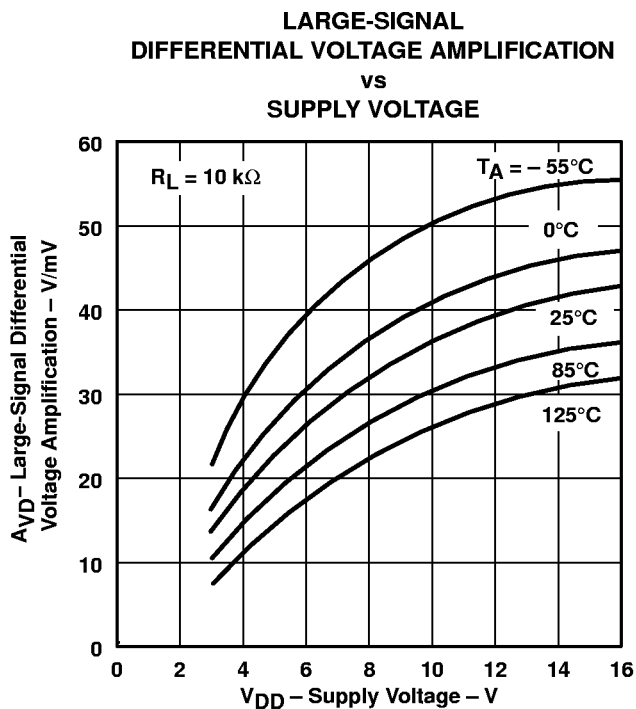

Figure 16

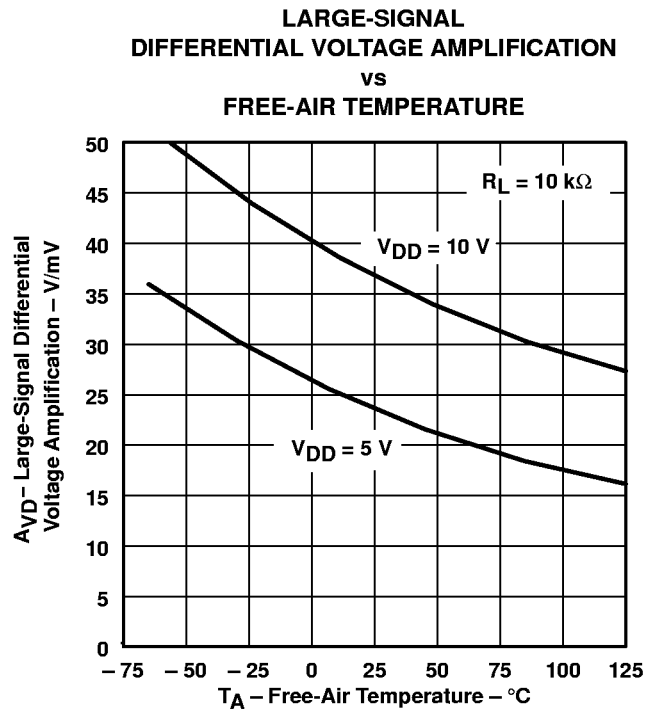
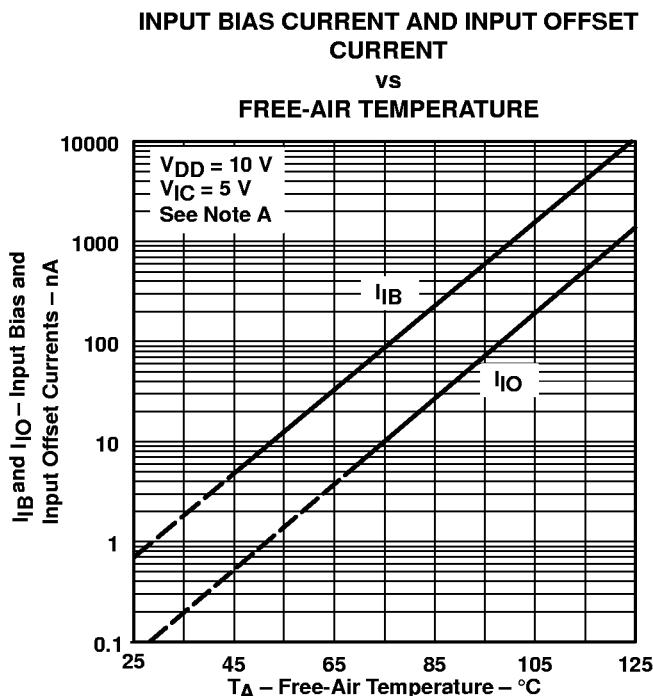

Figure 17

† Data at high and low temperatures are applicable only within the rated operating free-air temperature ranges of the various devices.

TYPICAL CHARACTERISTICS (HIGH-BIAS MODE)†



NOTE A: The typical values of input bias current and input offset current below 5 pA were determined mathematically.

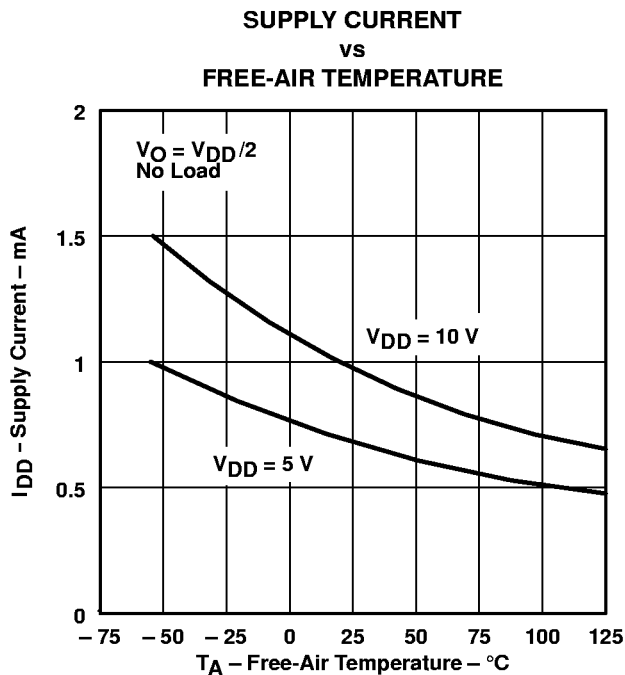
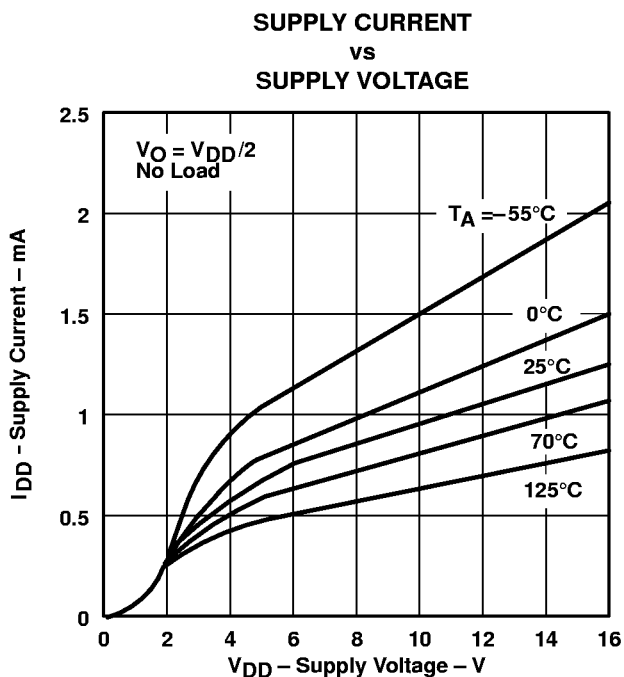
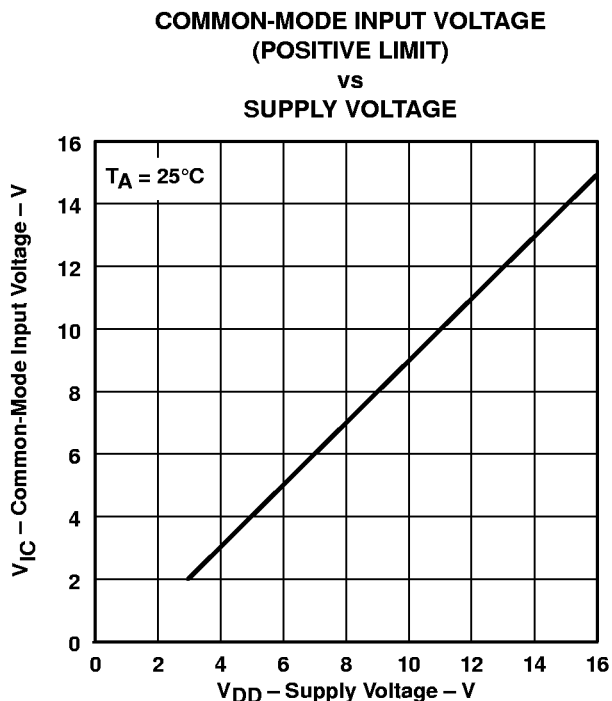

† Data at high and low temperatures are applicable only within the rated operating free-air temperature ranges of the various devices.

TYPICAL CHARACTERISTICS (HIGH-BIAS MODE)†

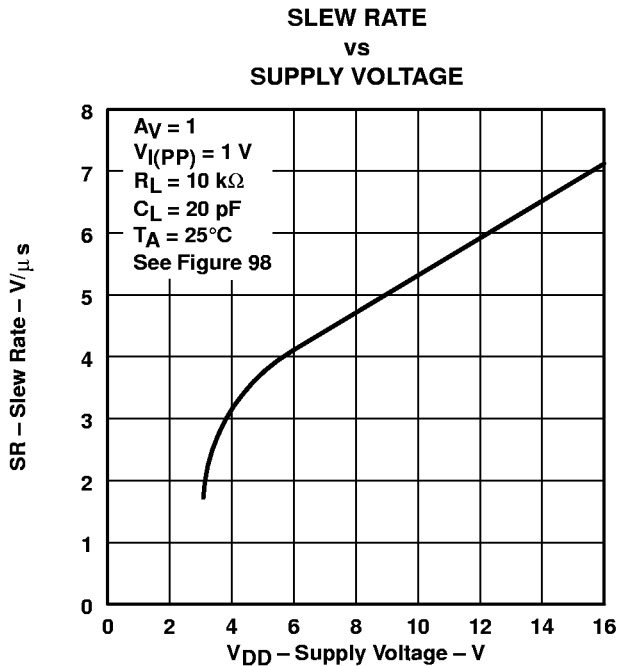

Figure 22

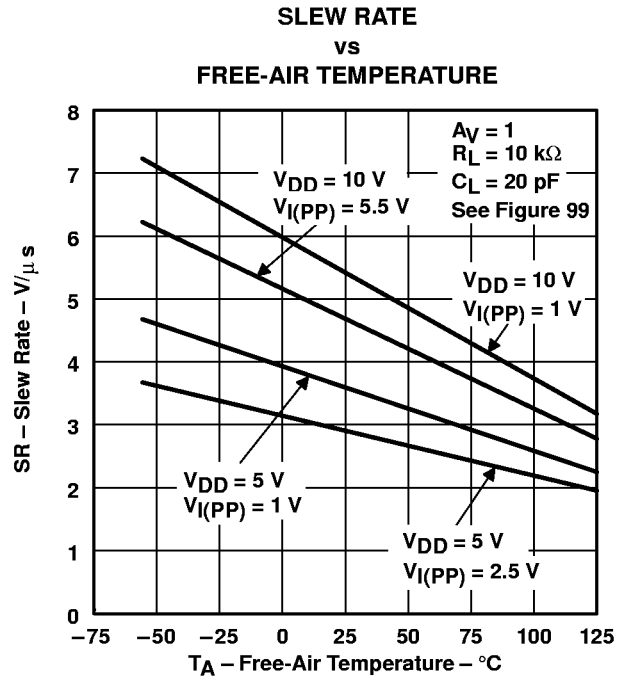

Figure 23

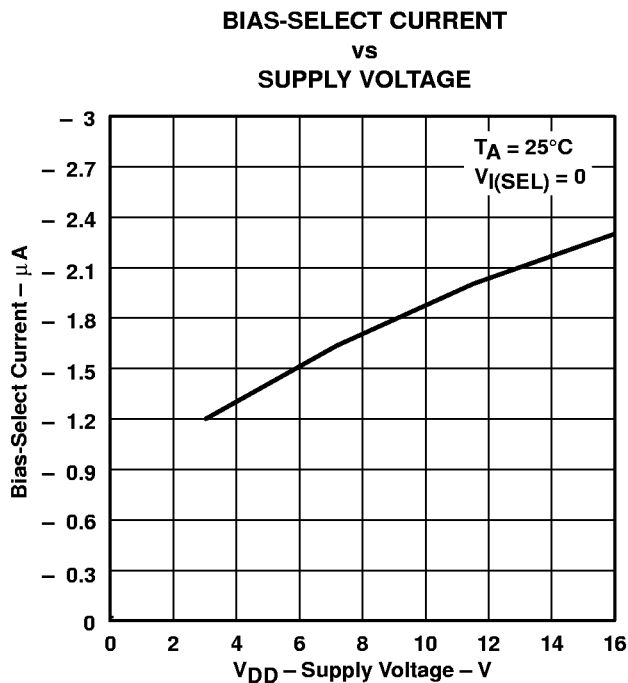

Figure 24

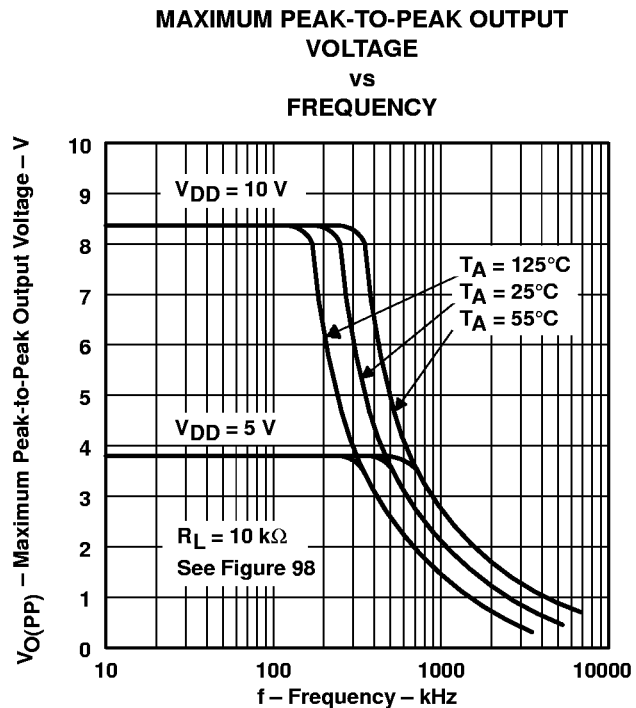

Figure 25

† Data at high and low temperatures are applicable only within the rated operating free-air temperature ranges of the various devices.

TYPICAL CHARACTERISTICS (HIGH-BIAS MODE)†

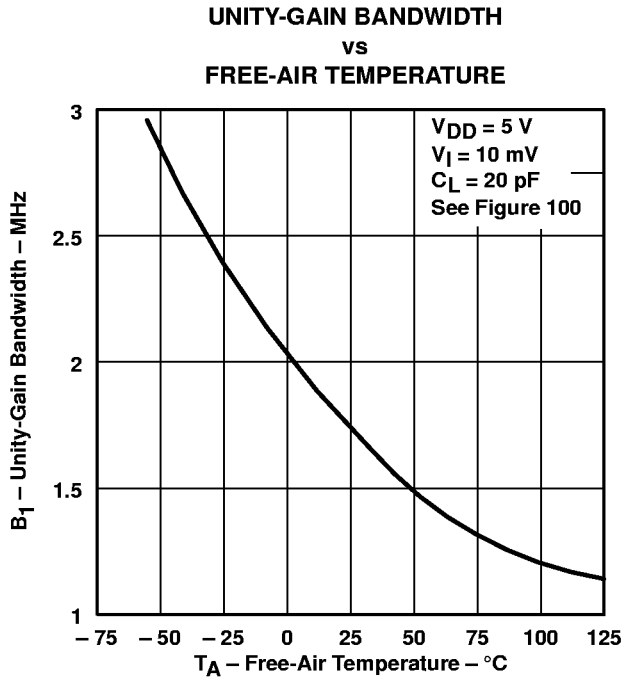

Figure 26

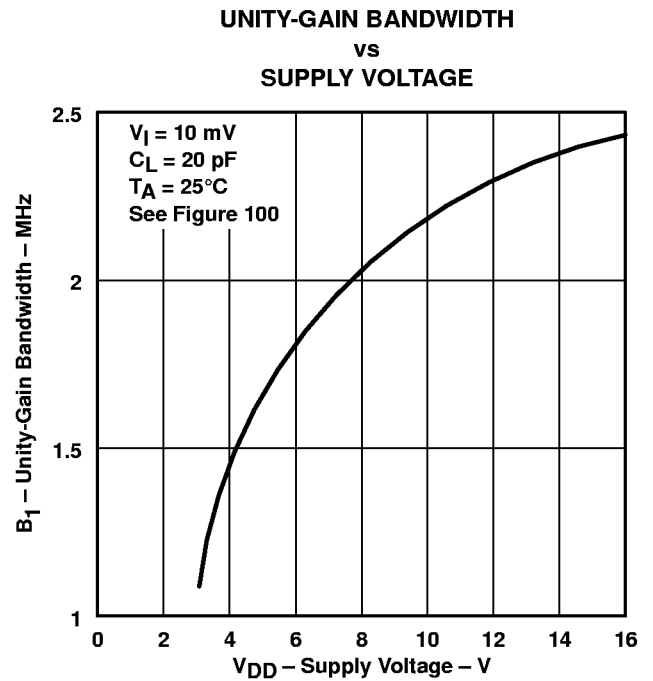

Figure 27

**LARGE-SIGNAL DIFFERENTIAL VOLTAGE
AMPLIFICATION AND PHASE SHIFT
vs
FREQUENCY**

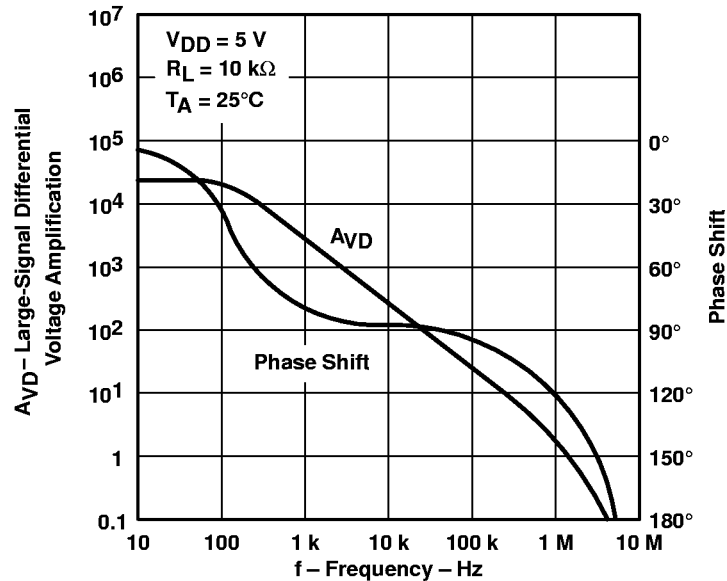

Figure 28

† Data at high and low temperatures are applicable only within the rated operating free-air temperature ranges of the various devices.

TYPICAL CHARACTERISTICS (HIGH-BIAS MODE)†

LARGE-SCALE DIFFERENTIAL VOLTAGE
 AMPLIFICATION AND PHASE SHIFT

vs
 FREQUENCY

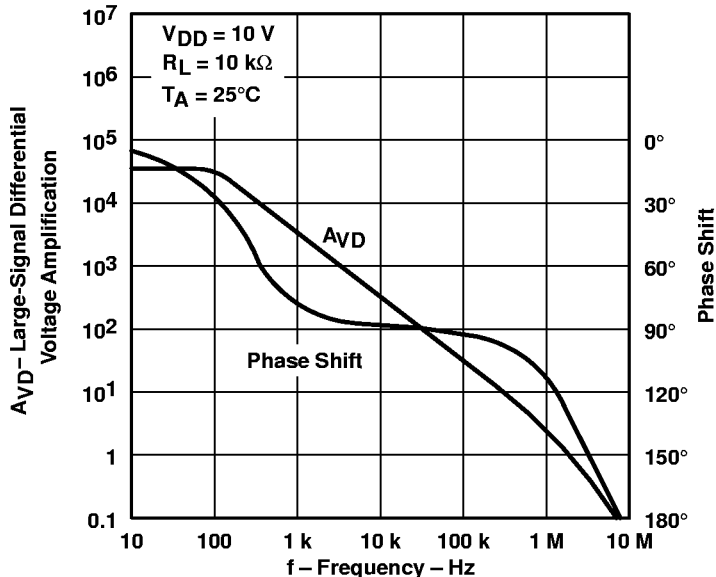

Figure 29

PHASE MARGIN
 vs
 SUPPLY VOLTAGE

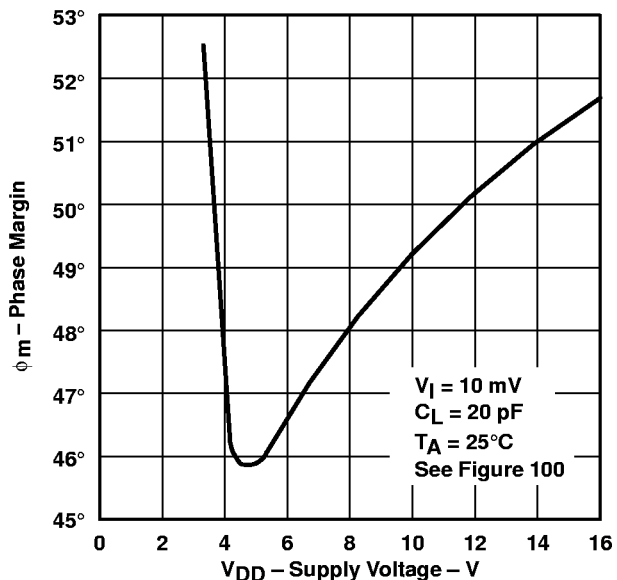

Figure 30

PHASE MARGIN
 vs
 FREE-AIR TEMPERATURE

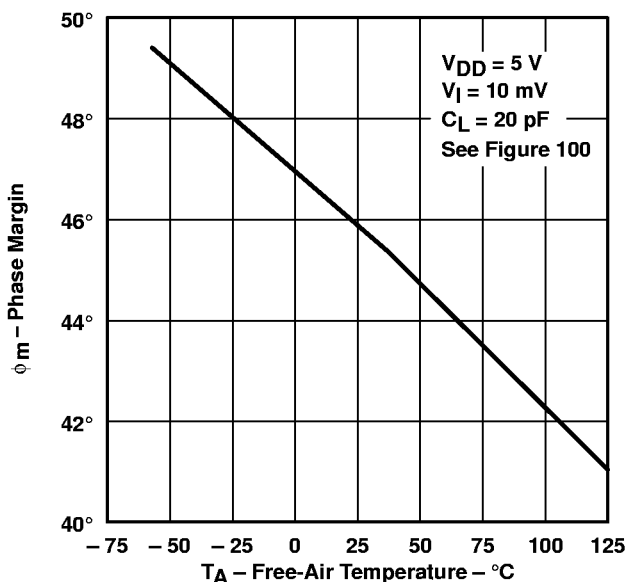

Figure 31

† Data at high and low temperatures are applicable only within the rated operating free-air temperature ranges of the various devices.

TYPICAL CHARACTERISTICS (HIGH-BIAS MODE)†

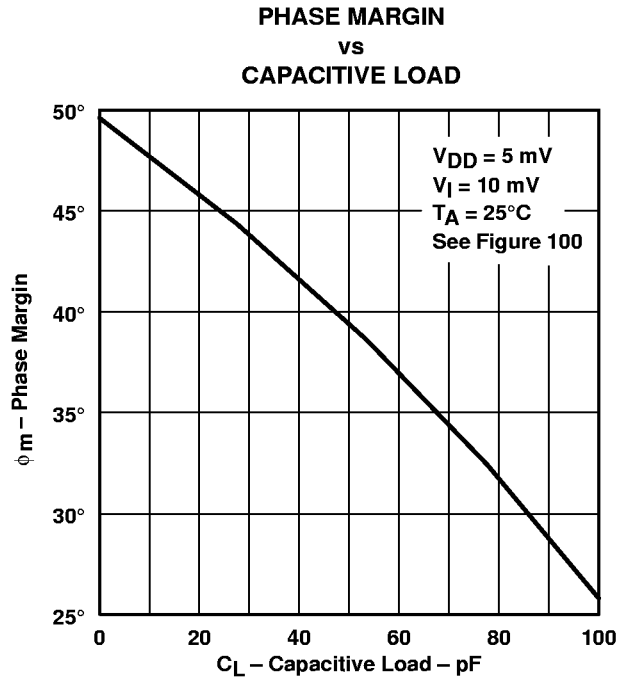

Figure 32

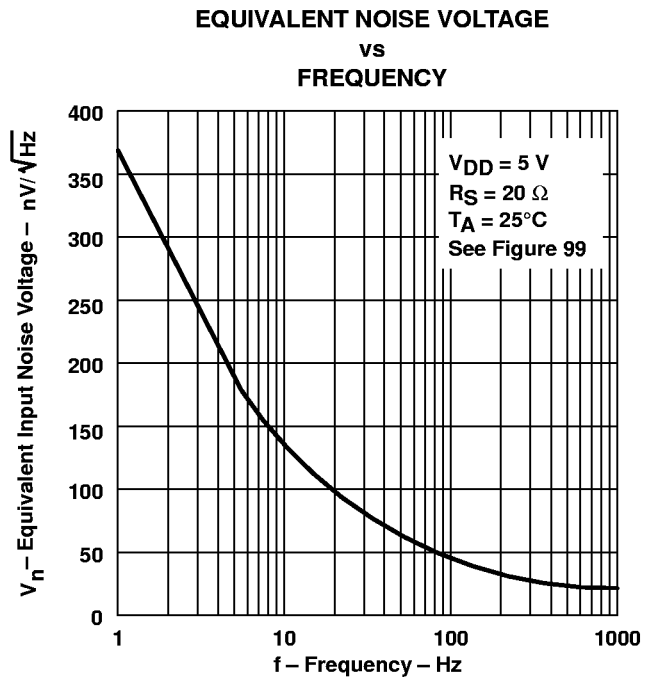

Figure 33

† Data at high and low temperatures are applicable only within the rated operating free-air temperature ranges of the various devices.

TLC271, TLC271A, TLC271B
LinCMOS™ PROGRAMMABLE LOW-POWER
OPERATIONAL AMPLIFIERS

SLOS090C – NOVEMBER 1987 – REVISED AUGUST 1997

MEDIUM-BIAS MODE

electrical characteristics at specified free-air temperature (unless otherwise noted)

| PARAMETER | | TEST CONDITIONS | T _A † | TLC271C, TLC271AC, TLC271BC | | | | | | UNIT |
|---------------------|--|---|------------------|-----------------------------|-------------|-----|------------------------|-------------|-----|-------|
| | | | | V _{DD} = 5 V | | | V _{DD} = 10 V | | | |
| | | | | MIN | TYP | MAX | MIN | TYP | MAX | |
| V _{IO} | Input offset voltage | V _O = 1.4 V, V _{IC} = 0 R _S = 50 Ω, R _I = 100 kΩ | 25°C | 1.1 | | 10 | 1.1 | | 10 | mV |
| | | | Full range | | | 12 | | | 12 | |
| | | | 25°C | 0.9 | | 5 | 0.9 | | 5 | |
| | | | Full range | | | 6.5 | | | 6.5 | |
| | | | 25°C | 0.25 | | 2 | 0.26 | | 2 | |
| | | | Full range | | | 3 | | | 3 | |
| α _{VIO} | Average temperature coefficient of input offset voltage | | 25°C to 70°C | 1.7 | | | 2.1 | | | μV/°C |
| I _{IO} | Input offset current (see Note 4) | V _O = V _{DD} /2, V _{IC} = V _{DD} /2 | 25°C | 0.1 | | | 0.1 | | | pA |
| | | | 70°C | 7 | | 300 | 7 | | 300 | |
| I _{IB} | Input bias current (see Note 4) | V _O = V _{DD} /2, V _{IC} = V _{DD} /2 | 25°C | 0.6 | | | 0.7 | | | pA |
| | | | 70°C | 40 | | 600 | 50 | | 600 | |
| V _{ICR} | Common-mode input voltage range (see Note 5) | | 25°C | -0.2 to 4 | -0.3 to 4.2 | | -0.2 to 9 | -0.3 to 9.2 | | V |
| | | | Full range | -0.2 to 3.5 | | | -0.2 to 8.5 | | | V |
| V _{OH} | High-level output voltage | V _{ID} = 100 mV, R _L = 100 kΩ | 25°C | 3.2 | 3.9 | | 8 | 8.7 | | V |
| | | | 0°C | 3 | 3.9 | | 7.8 | 8.7 | | |
| | | | 70°C | 3 | 4 | | 7.8 | 8.7 | | |
| V _{OL} | Low-level output voltage | V _{ID} = -100 mV, I _{OL} = 0 | 25°C | 0 | | 50 | 0 | | 50 | mV |
| | | | 0°C | 0 | | 50 | 0 | | 50 | |
| | | | 70°C | 0 | | 50 | 0 | | 50 | |
| A _{VD} | Large-signal differential voltage amplification | R _L = 100 kΩ, See Note 6 | 25°C | 25 | 170 | | 25 | 275 | | V/mV |
| | | | 0°C | 15 | 200 | | 15 | 320 | | |
| | | | 70°C | 15 | 140 | | 15 | 230 | | |
| CMRR | Common-mode rejection ratio | V _{IC} = V _{ICRmin} | 25°C | 65 | 91 | | 65 | 94 | | dB |
| | | | 0°C | 60 | 91 | | 60 | 94 | | |
| | | | 70°C | 60 | 92 | | 60 | 94 | | |
| k _{SVR} | Supply-voltage rejection ratio (ΔV _{DD} /ΔV _{IO}) | V _{DD} = 5 V to 10 V V _O = 1.4 V | 25°C | 70 | 93 | | 70 | 93 | | dB |
| | | | 0°C | 60 | 92 | | 60 | 92 | | |
| | | | 70°C | 60 | 94 | | 60 | 94 | | |
| I _{I(SEL)} | Input current (BIAS SELECT) | V _{I(SEL)} = V _{DD} /2 | 25°C | -130 | | | -160 | | | nA |
| I _{DD} | Supply current | V _O = V _{DD} /2, V _{IC} = V _{DD} /2, No load | 25°C | 105 | 280 | | 143 | 300 | | μA |
| | | | 0°C | 125 | 320 | | 173 | 400 | | |
| | | | 70°C | 85 | 220 | | 110 | 280 | | |

† Full range is 0°C to 70°C.

- NOTES: 4. The typical values of input bias current and input offset current below 5 pA were determined mathematically.
5. This range also applies to each input individually.
6. At V_{DD} = 5 V, V_O = 0.25 V to 2 V; at V_{DD} = 10 V, V_O = 1 V to 6 V.



MEDIUM-BIAS MODE

electrical characteristics at specified free-air temperature (unless otherwise noted)

| PARAMETER | | TEST CONDITIONS | T _A † | TLC271I, TLC271AI, TLC271BI | | | | | | UNIT |
|---------------------|--|--|------------------|-----------------------------|-------------|-------------|------------------------|-----|-------|------|
| | | | | V _{DD} = 5 V | | | V _{DD} = 10 V | | | |
| | | | | MIN | TYP | MAX | MIN | TYP | MAX | |
| V _{IO} | Input offset voltage | V _O = 1.4 V, V _{IC} = 0 V, R _S = 50 Ω, R _L = 100 kΩ | 25°C | 1.1 | | 10 | 1.1 | | 10 | mV |
| | | | Full range | | | | 13 | | | |
| | | | 25°C | 0.9 | | 5 | 0.9 | | 5 | |
| | | | Full range | | | | 7 | | | |
| | | | 25°C | 0.25 | | 2 | 0.26 | | 2 | |
| | | | Full range | | | | 3.5 | | | |
| α _{VIO} | Average temperature coefficient of input offset voltage | | 25°C to 85°C | 1.7 | | 2.1 | | | μV/°C | |
| I _{IO} | Input offset current (see Note 4) | V _O = V _{DD} /2, V _{IC} = V _{DD} /2 | 25°C | 0.1 | | 0.1 | | | pA | |
| | | | 85°C | 24 | 1000 | 26 | 1000 | | | |
| I _{IB} | Input bias current (see Note 4) | V _O = V _{DD} /2, V _{IC} = V _{DD} /2 | 25°C | 0.6 | | 0.7 | | | pA | |
| | | | 85°C | 200 | 2000 | 220 | 2000 | | | |
| V _{ICR} | Common-mode input voltage range (see Note 5) | | 25°C | -0.2 to 4 | -0.3 to 4.2 | -0.2 to 9 | -0.3 to 9.2 | | V | |
| | | | Full range | -0.2 to 3.5 | | -0.2 to 8.5 | | V | | |
| V _{OH} | High-level output voltage | V _{ID} = 100 mV, R _L = 100 kΩ | 25°C | 3.2 | 3.9 | 8 | 8.7 | | V | |
| | | | -40°C | 3 | 3.9 | 7.8 | 8.7 | | | |
| | | | 85°C | 3 | 4 | 7.8 | 8.7 | | | |
| V _{OL} | Low-level output voltage | V _{ID} = -100 mV, I _{OL} = 0 | 25°C | 0 | | 50 | 0 | | 50 | mV |
| | | | -40°C | 0 | | 50 | 0 | | 50 | |
| | | | 85°C | 0 | | 50 | 0 | | 50 | |
| A _{VD} | Large-signal differential voltage amplification | R _L = 100 kΩ, See Note 6 | 25°C | 25 | 170 | 25 | 275 | | V/mV | |
| | | | -40°C | 15 | 270 | 15 | 390 | | | |
| | | | 85°C | 15 | 130 | 15 | 220 | | | |
| CMRR | Common-mode rejection ratio | V _{IC} = V _{ICRmin} | 25°C | 65 | 91 | 65 | 94 | | dB | |
| | | | -40°C | 60 | 90 | 60 | 93 | | | |
| | | | 85°C | 60 | 90 | 60 | 94 | | | |
| k _{SVR} | Supply-voltage rejection ratio (ΔV _{DD} /ΔV _{IO}) | V _{DD} = 5 V to 10 V V _O = 1.4 V | 25°C | 70 | 93 | 70 | 93 | | dB | |
| | | | -40°C | 60 | 91 | 60 | 91 | | | |
| | | | 85°C | 60 | 94 | 60 | 94 | | | |
| I _{I(SEL)} | Input current (BIAS SELECT) | V _{I(SEL)} = V _{DD} /2 | 25°C | -130 | | -160 | | | nA | |
| I _{DD} | Supply current | V _O = V _{DD} /2, V _{IC} = V _{DD} /2, No load | 25°C | 105 | | 280 | 143 | | 300 | μA |
| | | | -40°C | 158 | | 400 | 225 | | 450 | |
| | | | 85°C | 80 | | 200 | 103 | | 260 | |

† Full range is -40°C to 85°C.

- NOTES: 4. The typical values of input bias current and input offset current below 5 pA were determined mathematically.
5. This range also applies to each input individually.
6. At V_{DD} = 5 V, V_O = 0.25 V to 2 V; at V_{DD} = 10 V, V_O = 1 V to 6 V.

TLC271, TLC271A, TLC271B
LinCMOS™ PROGRAMMABLE LOW-POWER
OPERATIONAL AMPLIFIERS

SLOS090C – NOVEMBER 1987 – REVISED AUGUST 1997

MEDIUM-BIAS MODE

electrical characteristics at specified free-air temperature (unless otherwise noted)

| PARAMETER | TEST CONDITIONS | T _A † | TLC271M | | | | | | UNIT |
|---|--|------------------|-----------------------|-------------|-----|------------------------|----------|-------------|-------|
| | | | V _{DD} = 5 V | | | V _{DD} = 10 V | | | |
| | | | MIN | TYP | MAX | MIN | TYP | MAX | |
| V _{IO} Input offset voltage | V _O = 1.4 V, V _{IC} = 0 V, R _S = 50 Ω, R _L = 100 kΩ | 25°C | | 1.1 | 10 | | 1.1 | 10 | mV |
| | | Full range | | | | 12 | | | |
| α _{VIO} Average temperature coefficient of input offset voltage | | 25°C to 125°C | | 1.7 | | | 2.1 | | μV/°C |
| I _{IO} Input offset current (see Note 4) | V _O = V _{DD} /2, V _{IC} = V _{DD} /2 | 25°C | | 0.1 | | | 0.1 | | pA |
| | | 125°C | | 1.4 | 15 | | 1.8 | 15 | nA |
| I _{IB} Input bias current (see Note 4) | V _O = V _{DD} /2, V _{IC} = V _{DD} /2 | 25°C | | 0.6 | | | 0.7 | | pA |
| | | 125°C | | 9 | 35 | | 10 | 35 | nA |
| V _{ICR} Common-mode input voltage range (see Note 5) | | 25°C | 0 to 4 | -0.3 to 4.2 | | | 0 to 9 | -0.3 to 9.2 | V |
| | | Full range | 0 to 3.5 | | | | 0 to 8.5 | | V |
| V _{OH} High-level output voltage | V _{ID} = 100 mV, R _L = 100 kΩ | 25°C | 3.2 | 3.9 | | | 8 | 8.7 | V |
| | | -55°C | 3 | 3.9 | | | 7.8 | 8.6 | |
| | | 125°C | 3 | 4 | | | 7.8 | 8.6 | |
| V _{OL} Low-level output voltage | V _{ID} = -100 mV, I _{OL} = 0 | 25°C | | 0 | 50 | | 0 | 50 | mV |
| | | -55°C | | 0 | 50 | | 0 | 50 | |
| | | 125°C | | 0 | 50 | | 0 | 50 | |
| A _{VD} Large-signal differential voltage amplification | R _L = 10 kΩ See Note 6 | 25°C | 25 | 170 | | | 25 | 275 | V/mV |
| | | -55°C | 15 | 290 | | | 15 | 420 | |
| | | 125°C | 15 | 120 | | | 15 | 190 | |
| CMRR Common-mode rejection ratio | V _{IC} = V _{ICRmin} | 25°C | 65 | 91 | | | 65 | 94 | dB |
| | | -55°C | 60 | 89 | | | 60 | 93 | |
| | | 125°C | 60 | 91 | | | 60 | 93 | |
| k _{SVR} Supply-voltage rejection ratio (ΔV _{DD} /ΔV _{IO}) | V _{DD} = 5 V to 10 V V _O = 1.4 V | 25°C | 70 | 93 | | | 70 | 93 | dB |
| | | -55°C | 60 | 91 | | | 60 | 91 | |
| | | 125°C | 60 | 94 | | | 60 | 94 | |
| I _{I(SEL)} Input current (BIAS SELECT) | V _{I(SEL)} = V _{DD} /2 | 25°C | | -130 | | | -160 | nA | |
| I _{DD} Supply current | V _O = V _{DD} /2, V _{IC} = V _{DD} /2, No load | 25°C | | 105 | 280 | | 143 | 300 | μA |
| | | -55°C | | 170 | 440 | | 245 | 500 | |
| | | 125°C | | 70 | 180 | | 90 | 240 | |

† Full range is -55°C to 125°C.

- NOTES: 4. The typical values of input bias current and input offset current below 5 pA were determined mathematically.
5. This range also applies to each input individually.
6. At V_{DD} = 5 V, V_O = 0.25 V to 2 V; at V_{DD} = 10 V, V_O = 1 V to 6 V.



MEDIUM-BIAS MODE

operating characteristics at specified free-air temperature, $V_{DD} = 5\text{ V}$

| PARAMETER | TEST CONDITIONS | T_A | TLC271C, TLC271AC, TLC271BC | | | UNIT |
|---|---|---|--------------------------------|------|------------------------|------------|
| | | | MIN | TYP | MAX | |
| SR Slew rate at unity gain | $R_L = 100\text{ k}\Omega$, $C_L = 20\text{ pF}$, See Figure 98 | $V_{I(PP)} = 1\text{ V}$ | 25°C | 0.43 | | V/ μ s |
| | | | 0°C | 0.46 | | |
| | | | 70°C | 0.36 | | |
| | | $V_{I(PP)} = 2.5\text{ V}$ | 25°C | 0.40 | | |
| | | | 0°C | 0.43 | | |
| | | | 70°C | 0.34 | | |
| V_n Equivalent input noise voltage | $f = 1\text{ kHz}$, See Figure 99 | $R_S = 20\ \Omega$, 25°C | 32 | | nV/ $\sqrt{\text{Hz}}$ | |
| B_{OM} Maximum output-swing bandwidth | $V_O = V_{OH}$, $R_L = 100\text{ k}\Omega$, | $C_L = 20\text{ pF}$, See Figure 98 | 25°C | 55 | | kHz |
| | | | 0°C | 60 | | |
| | | | 70°C | 50 | | |
| B_1 Unity-gain bandwidth | $V_I = 10\text{ mV}$, See Figure 100 | $C_L = 20\text{ pF}$, | 25°C | 525 | | kHz |
| | | | 0°C | 600 | | |
| | | | 70°C | 400 | | |
| ϕ_m Phase margin | $V_I = 10\text{ mV}$, $C_L = 20\text{ pF}$, | $f = B_1$, See Figure 100 | 25°C | 40° | | |
| | | | 0°C | 41° | | |
| | | | 70°C | 39° | | |

operating characteristics at specified free-air temperature, $V_{DD} = 10\text{ V}$

| PARAMETER | TEST CONDITIONS | T_A | TLC271C, TLC271AC, TLC271BC | | | UNIT |
|---|---|---|--------------------------------|------|------------------------|------------|
| | | | MIN | TYP | MAX | |
| SR Slew rate at unity gain | $R_L = 100\text{ k}\Omega$, $C_L = 20\text{ pF}$, See Figure 98 | $V_{I(PP)} = 1\text{ V}$ | 25°C | 0.62 | | V/ μ s |
| | | | 0°C | 0.67 | | |
| | | | 70°C | 0.51 | | |
| | | $V_{I(PP)} = 5.5\text{ V}$ | 25°C | 0.56 | | |
| | | | 0°C | 0.61 | | |
| | | | 70°C | 0.46 | | |
| V_n Equivalent input noise voltage | $f = 1\text{ kHz}$, See Figure 99 | $R_S = 20\ \Omega$, 25°C | 32 | | nV/ $\sqrt{\text{Hz}}$ | |
| B_{OM} Maximum output-swing bandwidth | $V_O = V_{OH}$, $R_L = 100\text{ k}\Omega$, | $C_L = 20\text{ pF}$, See Figure 98 | 25°C | 35 | | kHz |
| | | | 0°C | 40 | | |
| | | | 70°C | 30 | | |
| B_1 Unity-gain bandwidth | $V_I = 10\text{ mV}$, See Figure 100 | $C_L = 20\text{ pF}$, | 25°C | 635 | | kHz |
| | | | 0°C | 710 | | |
| | | | 70°C | 510 | | |
| ϕ_m Phase margin | $V_I = 10\text{ mV}$, $C_L = 20\text{ pF}$, | $f = B_1$, See Figure 100 | 25°C | 43° | | |
| | | | 0°C | 44° | | |
| | | | 70°C | 42° | | |

TLC271, TLC271A, TLC271B
LinCMOS™ PROGRAMMABLE LOW-POWER
OPERATIONAL AMPLIFIERS

SLOS090C – NOVEMBER 1987 – REVISED AUGUST 1997

MEDIUM-BIAS MODE

operating characteristics at specified free-air temperature, $V_{DD} = 5\text{ V}$

| PARAMETER | TEST CONDITIONS | T_A | TLC271I, TLC271AI, TLC271BI | | | UNIT |
|---|---|--------------------------------|--------------------------------|------|------------------------|------------|
| | | | MIN | TYP | MAX | |
| SR Slew rate at unity gain | $R_L = 100\text{ k}\Omega$, $C_L = 20\text{ pF}$, See Figure 98 | $V_{I(PP)} = 1\text{ V}$ | 25°C | 0.43 | | V/ μ s |
| | | | -40°C | 0.51 | | |
| | | | 85°C | 0.35 | | |
| | | $V_{I(PP)} = 2.5\text{ V}$ | 25°C | 0.40 | | |
| | | | -40°C | 0.48 | | |
| | | | 85°C | 0.32 | | |
| V_n Equivalent input noise voltage | $f = 1\text{ kHz}$, See Figure 99 | $R_S = 20\ \Omega$, 25°C | 32 | | nV/ $\sqrt{\text{Hz}}$ | |
| B_{OM} Maximum output-swing bandwidth | $V_O = V_{OH}$, $R_L = 100\text{ k}\Omega$, $C_L = 20\text{ pF}$, See Figure 98 | 25°C | 55 | | kHz | |
| | | -40°C | 75 | | | |
| | | 85°C | 45 | | | |
| B_1 Unity-gain bandwidth | $V_I = 10\text{ mV}$, See Figure 100 | $C_L = 20\text{ pF}$, 25°C | 525 | | MHz | |
| | | | -40°C | 770 | | |
| | | | 85°C | 370 | | |
| ϕ_m Phase margin | $V_I = 10\text{ mV}$, $C_L = 20\text{ pF}$, $f = B_1$, See Figure 100 | 25°C | 40° | | | |
| | | -40°C | 43° | | | |
| | | 85°C | 38° | | | |

operating characteristics at specified free-air temperature, $V_{DD} = 10\text{ V}$

| PARAMETER | TEST CONDITIONS | T_A | TLC271I, TLC271AI, TLC271BI | | | UNIT |
|---|---|--------------------------------|--------------------------------|------|------------------------|------------|
| | | | MIN | TYP | MAX | |
| SR Slew rate at unity gain | $R_L = 100\text{ k}\Omega$, $C_L = 20\text{ pF}$, See Figure 98 | $V_{I(PP)} = 1\text{ V}$ | 25°C | 0.62 | | V/ μ s |
| | | | -40°C | 0.77 | | |
| | | | 85°C | 0.47 | | |
| | | $V_{I(PP)} = 5.5\text{ V}$ | 25°C | 0.56 | | |
| | | | -40°C | 0.70 | | |
| | | | 85°C | 0.44 | | |
| V_n Equivalent input noise voltage | $f = 1\text{ kHz}$, See Figure 99 | $R_S = 20\ \Omega$, 25°C | 32 | | nV/ $\sqrt{\text{Hz}}$ | |
| B_{OM} Maximum output-swing bandwidth | $V_O = V_{OH,3}$, $R_L = 100\text{ k}\Omega$, $C_L = 20\text{ pF}$, See Figure 98 | 25°C | 35 | | kHz | |
| | | -40°C | 45 | | | |
| | | 85°C | 25 | | | |
| B_1 Unity-gain bandwidth | $V_I = 10\text{ mV}$, See Figure 100 | $C_L = 20\text{ pF}$, 25°C | 635 | | kHz | |
| | | | -40°C | 880 | | |
| | | | 85°C | 480 | | |
| ϕ_m Phase margin | $V_I = 10\text{ mV}$, $C_L = 20\text{ pF}$, $f = B_1$, See Figure 100 | 25°C | 43° | | | |
| | | -40°C | 46° | | | |
| | | 85°C | 41° | | | |



MEDIUM-BIAS MODE

operating characteristics at specified free-air temperature, $V_{DD} = 5\text{ V}$

| PARAMETER | TEST CONDITIONS | T _A | TLC271M | | | UNIT |
|--|--|--|---------|------|--------|------|
| | | | MIN | TYP | MAX | |
| SR Slew rate at unity gain | R _L = 100 kΩ, C _L = 20 pF, See Figure 98 | V _{I(PP)} = 1 V | 25°C | 0.43 | | V/μs |
| | | | -55°C | 0.54 | | |
| | | | 125°C | 0.29 | | |
| | | V _{I(PP)} = 2.5 V | 25°C | 0.40 | | |
| | | | -55°C | 0.50 | | |
| | | | 125°C | 0.28 | | |
| V _n Equivalent input noise voltage | f = 1 kHz, See Figure 99 | R _S = 20 Ω, 25°C | 32 | | nV/√Hz | |
| B _{OM} Maximum output-swing bandwidth | V _O = V _{OH} , R _L = 100 kΩ, | C _L = 20 pF, See Figure 98 | 25°C | 55 | | kHz |
| | | | -55°C | 80 | | |
| | | | 125°C | 40 | | |
| B ₁ Unity-gain bandwidth | V _I = 10 mV, See Figure 100 | C _L = 20 pF, | 25°C | 525 | | kHz |
| | | | -55°C | 850 | | |
| | | | 125°C | 330 | | |
| φ _m Phase margin | V _I = 10 mV, C _L = 20 pF, | f = B ₁ , See Figure 100 | 25°C | 40° | | |
| | | | -55°C | 43° | | |
| | | | 125°C | 36° | | |

operating characteristics at specified free-air temperature, $V_{DD} = 10\text{ V}$

| PARAMETER | TEST CONDITIONS | T _A | TLC271M | | | UNIT |
|--|--|--|---------|------|--------|------|
| | | | MIN | TYP | MAX | |
| SR Slew rate at unity gain | R _L = 100 kΩ, C _L = 20 pF, See Figure 98 | V _{I(PP)} = 1 V | 25°C | 0.62 | | V/μs |
| | | | -55°C | 0.81 | | |
| | | | 125°C | 0.38 | | |
| | | V _{I(PP)} = 5.5 V | 25°C | 0.56 | | |
| | | | -55°C | 0.73 | | |
| | | | 125°C | 0.35 | | |
| V _n Equivalent input noise voltage | f = 1 kHz, See Figure 99 | R _S = 20 Ω, 25°C | 32 | | nV/√Hz | |
| B _{OM} Maximum output-swing bandwidth | V _O = V _{OH} , R _L = 100 kΩ, | C _L = 20 pF, See Figure 98 | 25°C | 35 | | kHz |
| | | | -55°C | 50 | | |
| | | | 125°C | 20 | | |
| B ₁ Unity-gain bandwidth | V _I = 10 mV, See Figure 100 | C _L = 20 pF, | 25°C | 635 | | kHz |
| | | | -55°C | 960 | | |
| | | | 125°C | 440 | | |
| φ _m Phase margin | V _I = 10 mV, C _L = 20 pF, | f = B ₁ , See Figure 100 | 25°C | 43° | | |
| | | | -55°C | 47° | | |
| | | | 125°C | 39° | | |

TLC271, TLC271A, TLC271B
LinCMOS™ PROGRAMMABLE LOW-POWER
OPERATIONAL AMPLIFIERS

SLOS090C – NOVEMBER 1987 – REVISED AUGUST 1997

TYPICAL CHARACTERISTICS (MEDIUM-BIAS MODE)

Table of Graphs

| | | | FIGURE |
|----------------|---|-------------------------------|---------------|
| V_{IO} | Input offset voltage | Distribution | 34, 35 |
| α_{VIO} | Temperature coefficient | Distribution | 36, 37 |
| V_{OH} | High-level output voltage | vs High-level output current | 38, 39 |
| | | vs Supply voltage | 40 |
| | | vs Free-air temperature | 41 |
| V_{OL} | Low-level output voltage | vs Common-mode input voltage | 42, 43 |
| | | vs Differential input voltage | 44 |
| | | vs Free-air temperature | 45 |
| | | vs Low-level output current | 46, 47 |
| A_{VD} | Large-signal differential voltage amplification | vs Supply voltage | 48 |
| | | vs Free-air temperature | 49 |
| | | vs Frequency | 60, 61 |
| I_{IB} | Input bias current | vs Free-air temperature | 50 |
| I_{IO} | Input offset current | vs Free-air temperature | 50 |
| V_I | Maximum Input voltage | vs Supply voltage | 51 |
| I_{DD} | Supply current | vs Supply voltage | 52 |
| | | vs Free-air temperature | 53 |
| SR | Slew rate | vs Supply voltage | 54 |
| | | vs Free-air temperature | 55 |
| | Bias-select current | vs Supply voltage | 56 |
| $V_{O(PP)}$ | Maximum peak-to-peak output voltage | vs Frequency | 57 |
| B_1 | Unity-gain bandwidth | vs Free-air temperature | 58 |
| | | vs Supply voltage | 59 |
| ϕ_m | Phase margin | vs Supply voltage | 62 |
| | | vs Free-air temperature | 63 |
| | | vs Capacitive load | 64 |
| V_n | Equivalent input noise voltage | vs Frequency | 65 |
| | | Phase shift | 60, 61 |



TYPICAL CHARACTERISTICS (MEDIUM-BIAS MODE)†

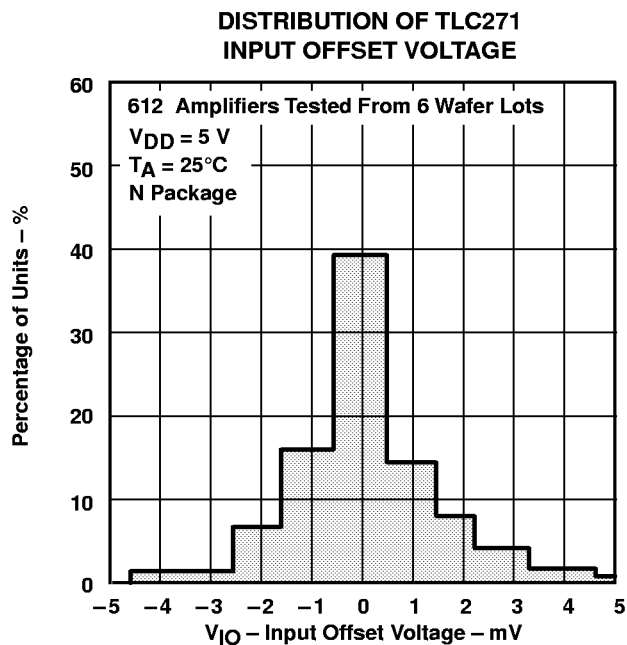

Figure 34

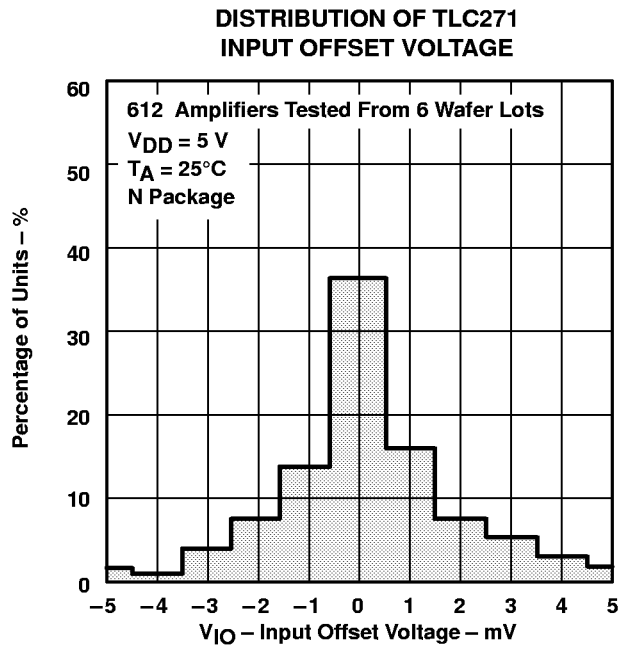

Figure 35

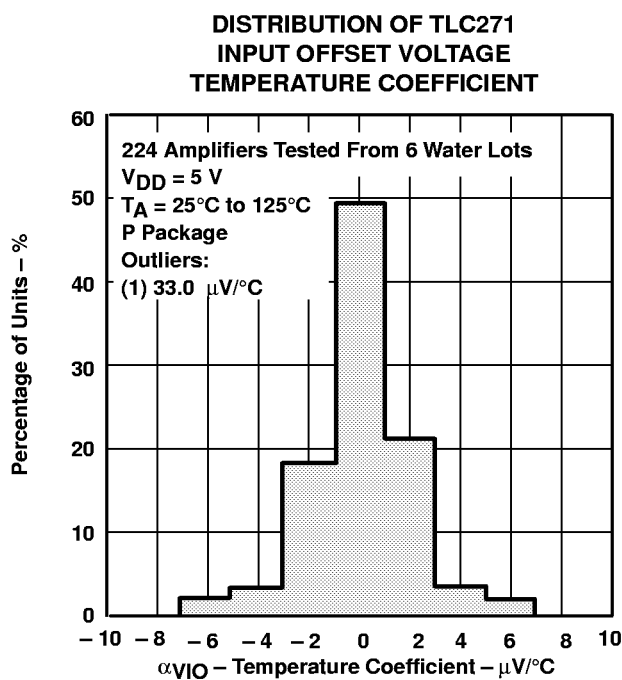

Figure 36

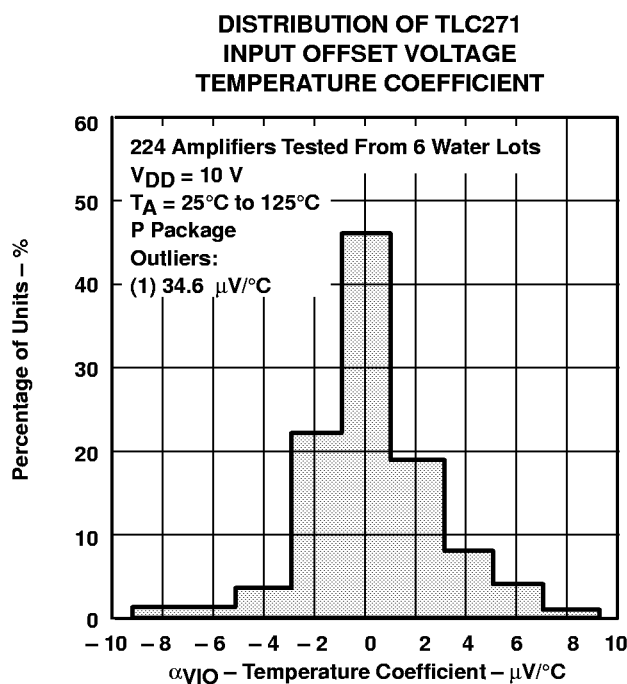

Figure 37

† Data at high and low temperatures are applicable only within the rated operating free-air temperature ranges of the various devices.

TYPICAL CHARACTERISTICS (MEDIUM-BIAS MODE)†

HIGH-LEVEL OUTPUT VOLTAGE
 vs
 HIGH-LEVEL OUTPUT CURRENT

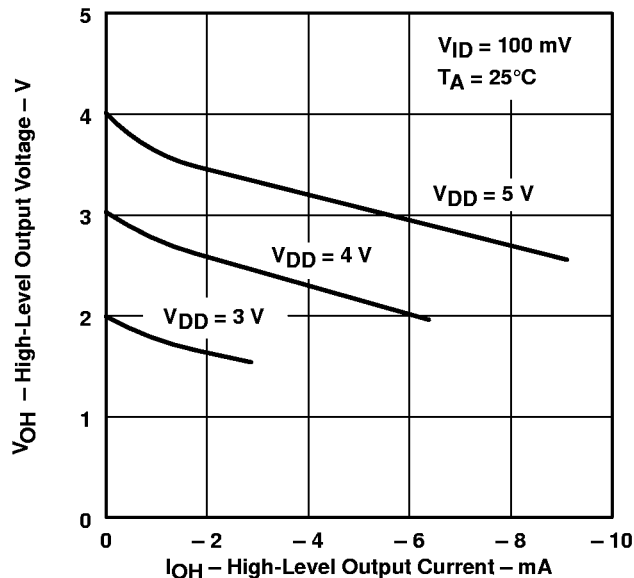

Figure 38

HIGH-LEVEL OUTPUT VOLTAGE
 vs
 HIGH-LEVEL OUTPUT CURRENT

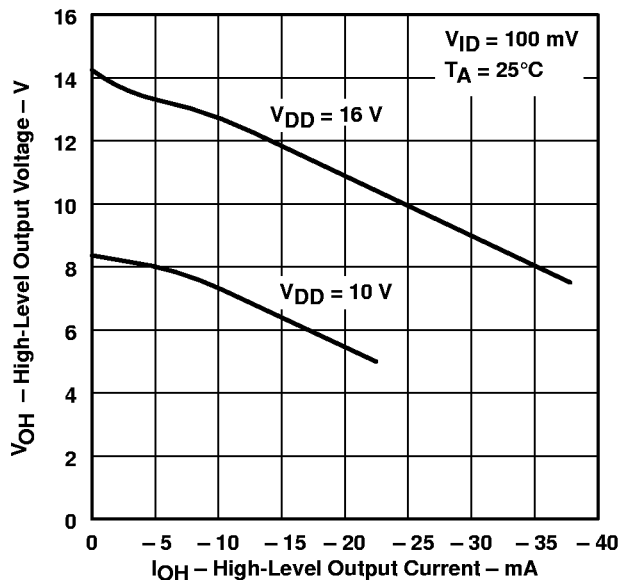

Figure 39

HIGH-LEVEL OUTPUT VOLTAGE
 vs
 SUPPLY VOLTAGE

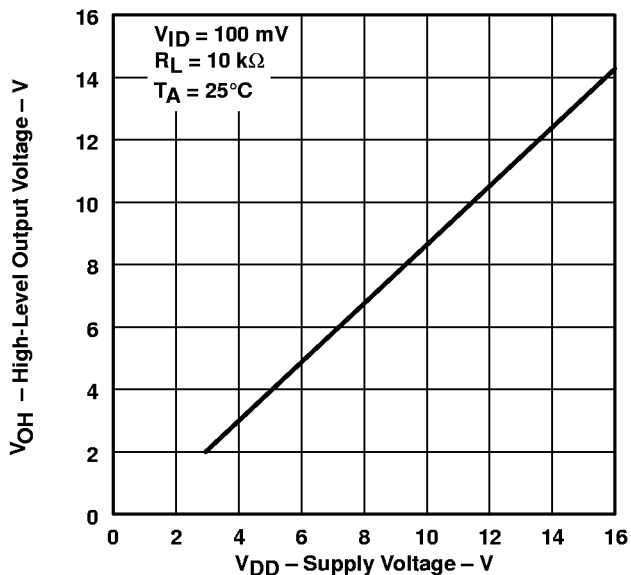

Figure 40

HIGH-LEVEL OUTPUT VOLTAGE
 vs
 FREE-AIR TEMPERATURE

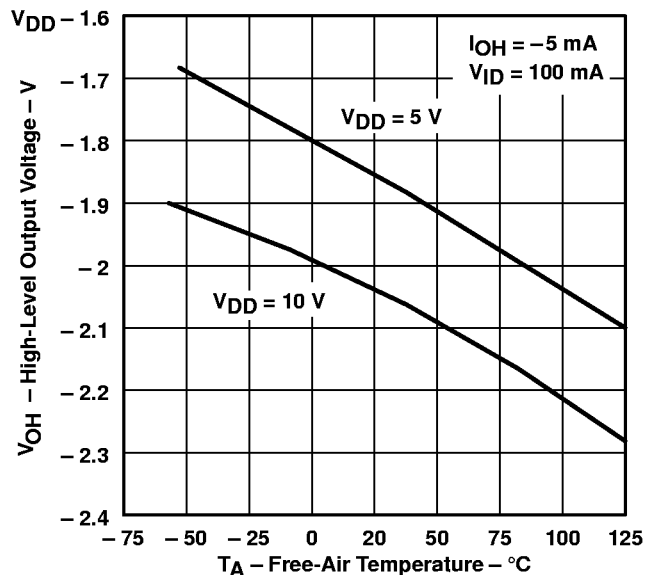

Figure 41

† Data at high and low temperatures are applicable only within the rated operating free-air temperature ranges of the various devices.

TYPICAL CHARACTERISTICS (MEDIUM-BIAS MODE)†

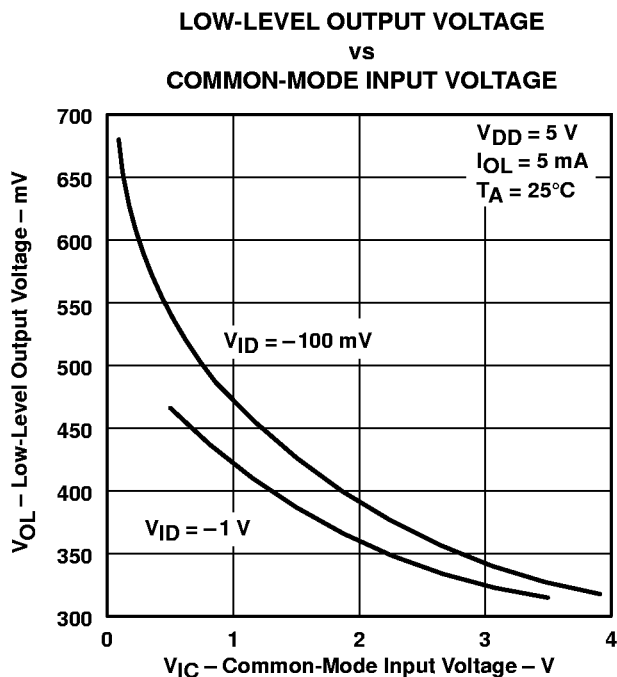

Figure 42

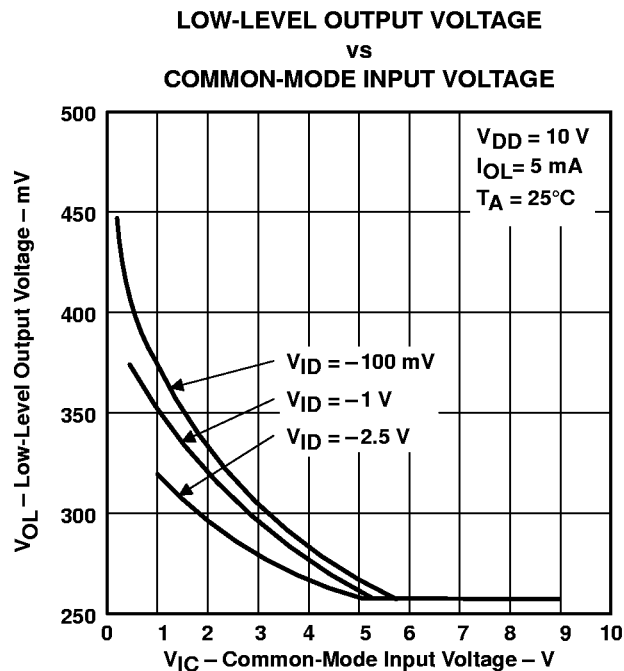

Figure 43

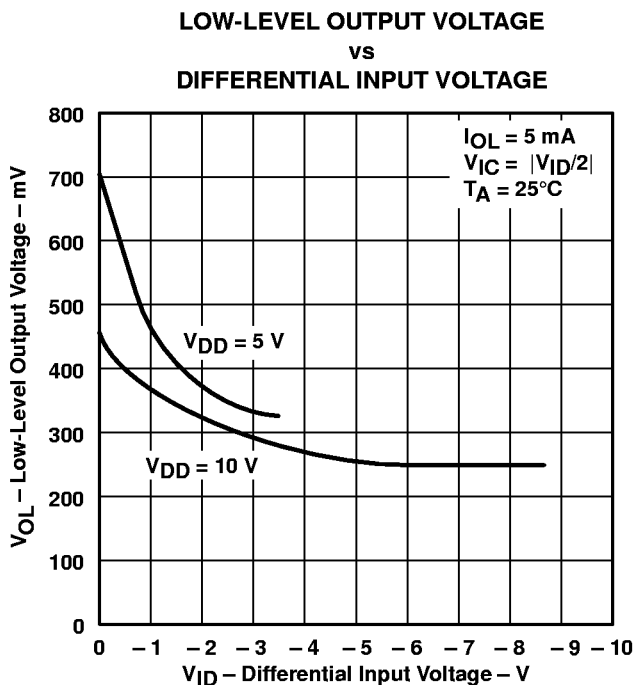

Figure 44

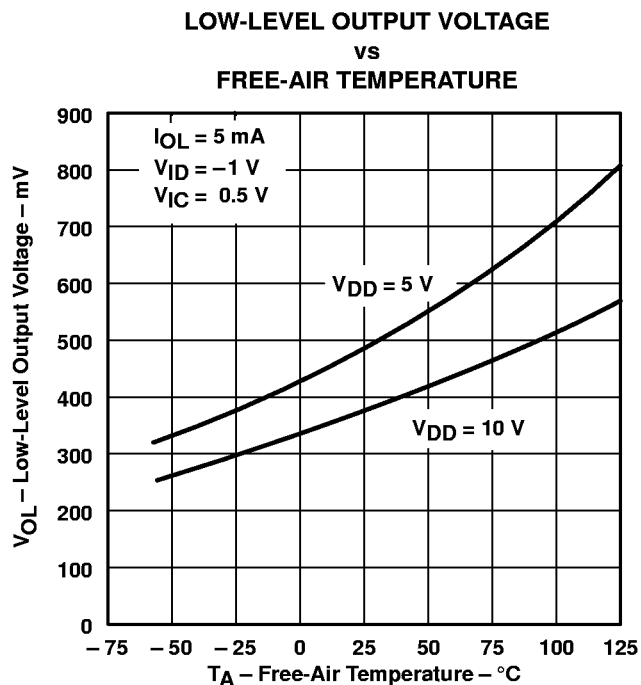

Figure 45

† Data at high and low temperatures are applicable only within the rated operating free-air temperature ranges of the various devices.

TYPICAL CHARACTERISTICS (MEDIUM-BIAS MODE)†

LOW-LEVEL OUTPUT VOLTAGE
 vs
 LOW-LEVEL OUTPUT CURRENT

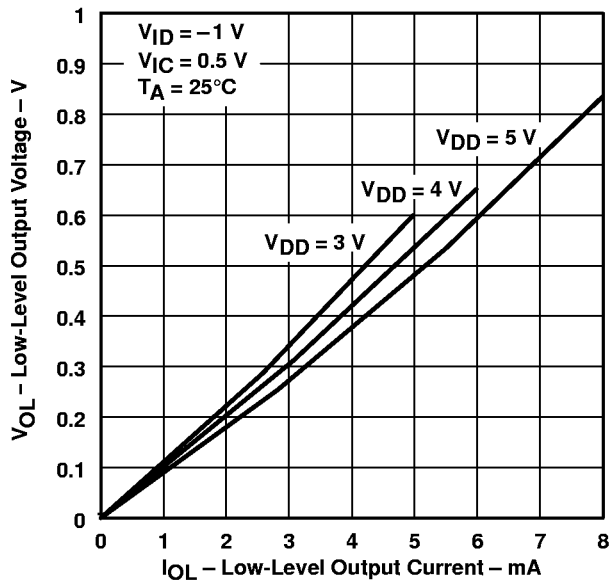

Figure 46

LOW-LEVEL OUTPUT VOLTAGE
 vs
 LOW-LEVEL OUTPUT CURRENT

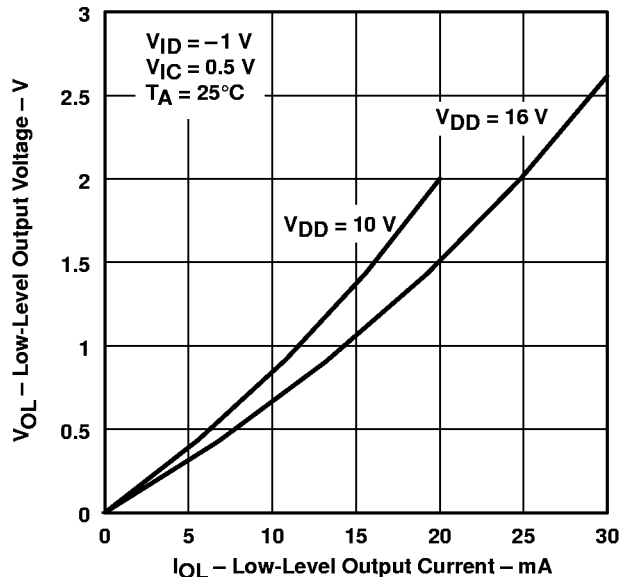

Figure 47

LARGE-SIGNAL
 DIFFERENTIAL VOLTAGE AMPLIFICATION
 vs
 SUPPLY VOLTAGE

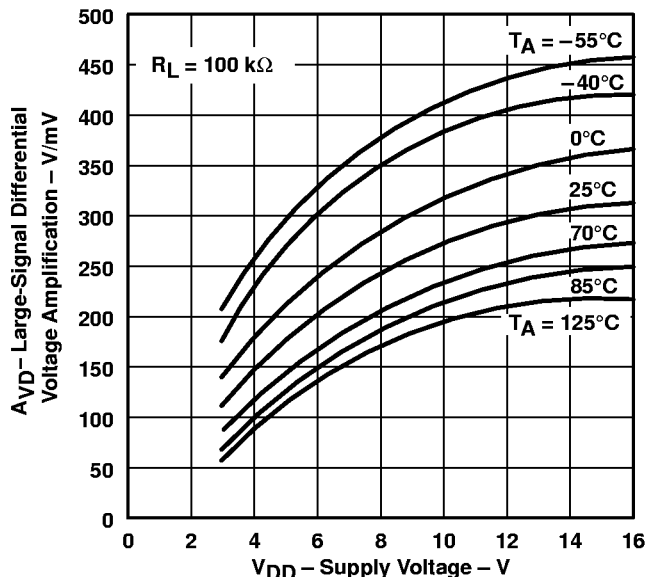

Figure 48

LARGE-SIGNAL
 DIFFERENTIAL VOLTAGE AMPLIFICATION
 vs
 FREE-AIR TEMPERATURE

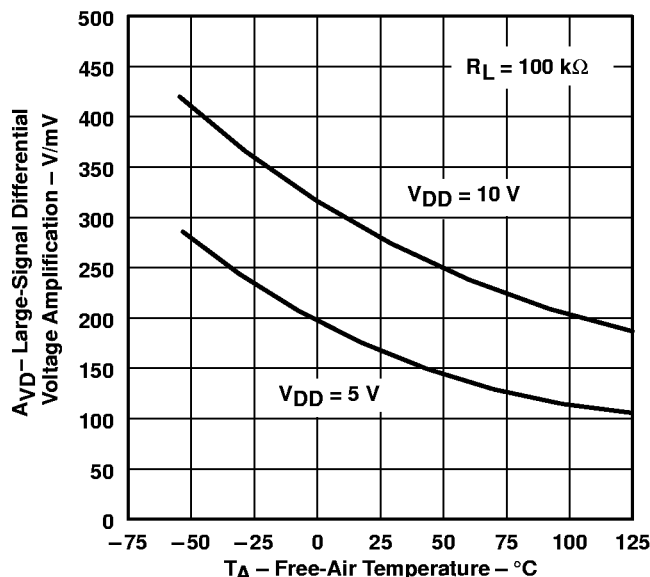
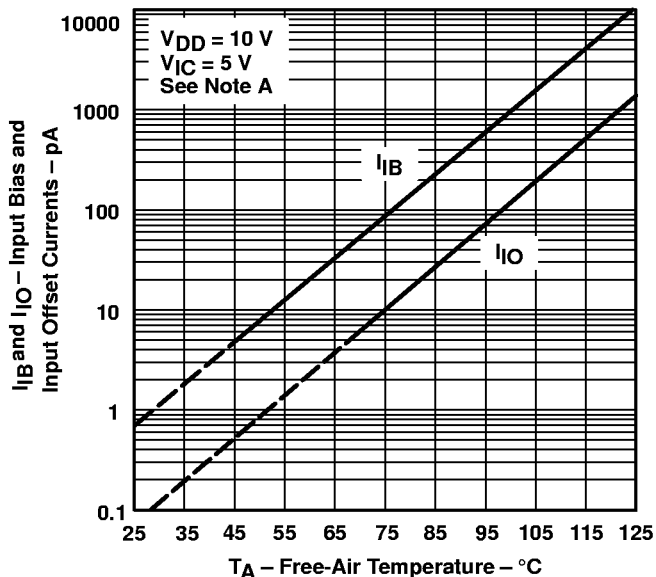

Figure 49

† Data at high and low temperatures are applicable only within the rated operating free-air temperature ranges of the various devices.

TYPICAL CHARACTERISTICS (MEDIUM-BIAS MODE)†

**INPUT BIAS CURRENT AND INPUT OFFSET
 CURRENT
 vs
 FREE-AIR TEMPERATURE**



NOTE A: The typical values of input bias current and input offset current below 5 pA were determined mathematically.

Figure 50

**MAXIMUM INPUT VOLTAGE
 vs
 SUPPLY VOLTAGE**

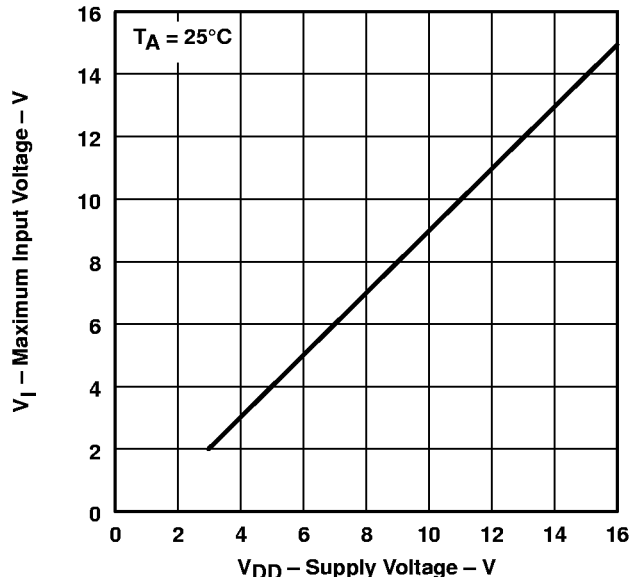

Figure 51

**SUPPLY CURRENT
 vs
 SUPPLY VOLTAGE**

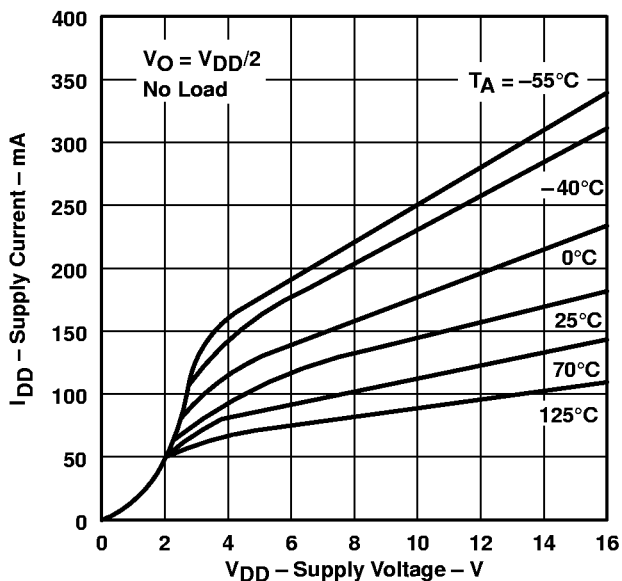

Figure 52

**SUPPLY CURRENT
 vs
 FREE-AIR TEMPERATURE**

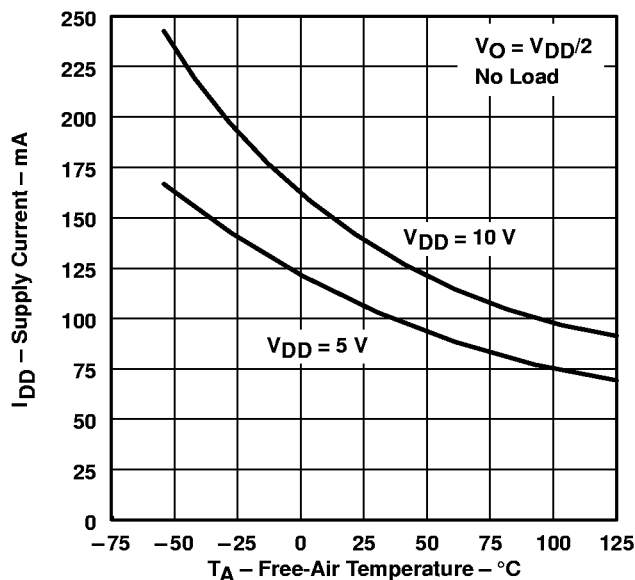

Figure 53

† Data at high and low temperatures are applicable only within the rated operating free-air temperature ranges of the various devices.

TYPICAL CHARACTERISTICS (MEDIUM-BIAS MODE)†

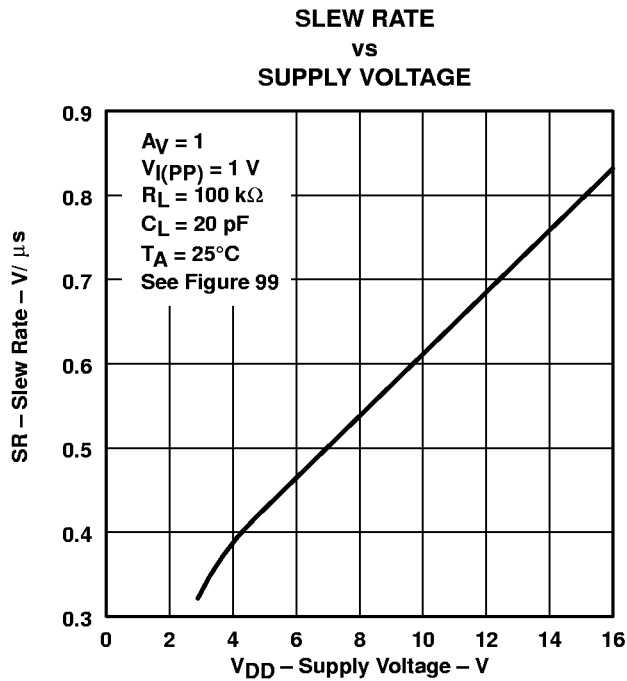

Figure 54

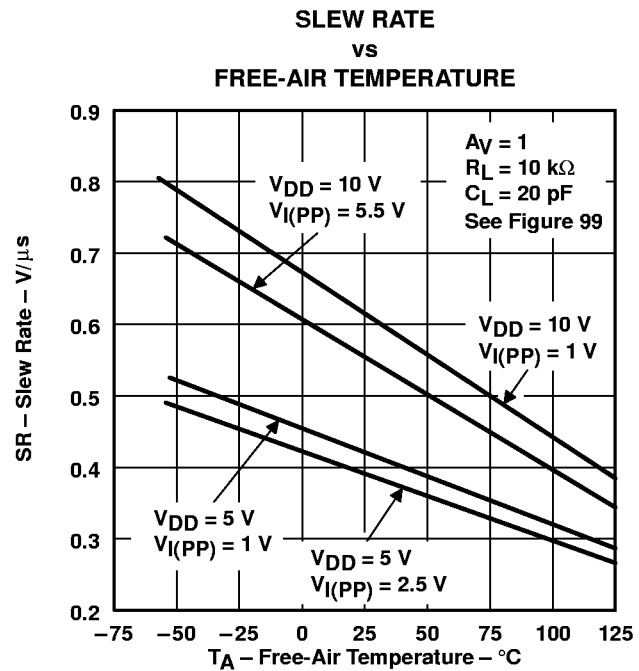

Figure 55

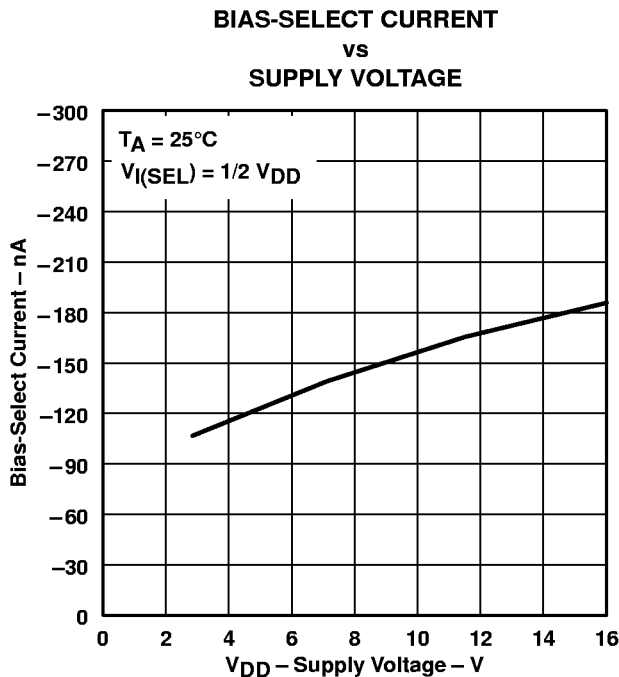

Figure 56

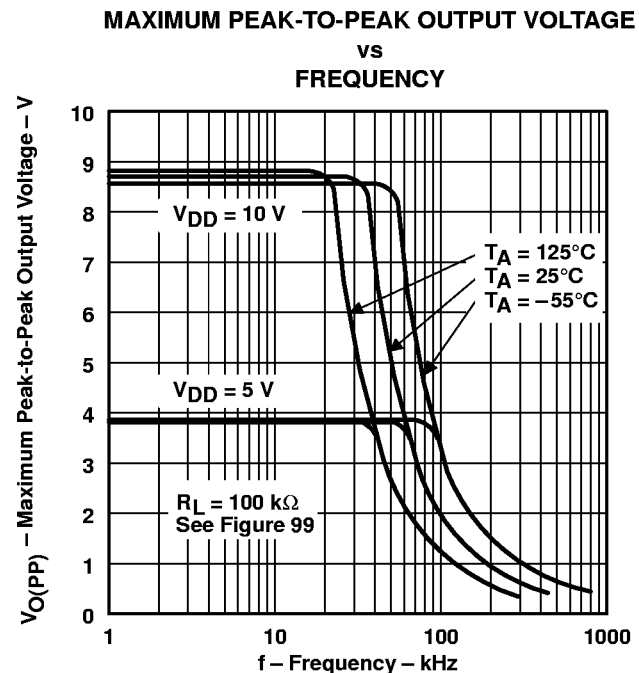

Figure 57

† Data at high and low temperatures are applicable only within the rated operating free-air temperature ranges of the various devices.

TYPICAL CHARACTERISTICS (MEDIUM-BIAS MODE)†

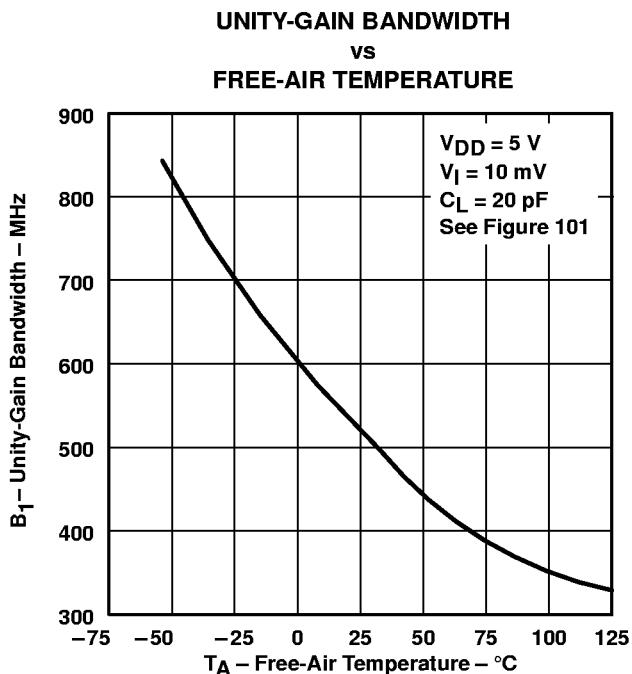

Figure 58

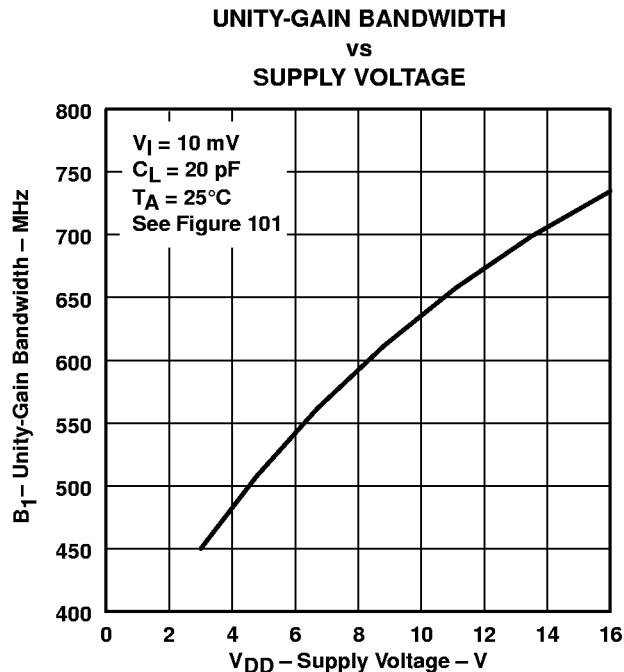

Figure 59

LARGE-SIGNAL DIFFERENTIAL VOLTAGE
 AMPLIFICATION AND PHASE SHIFT

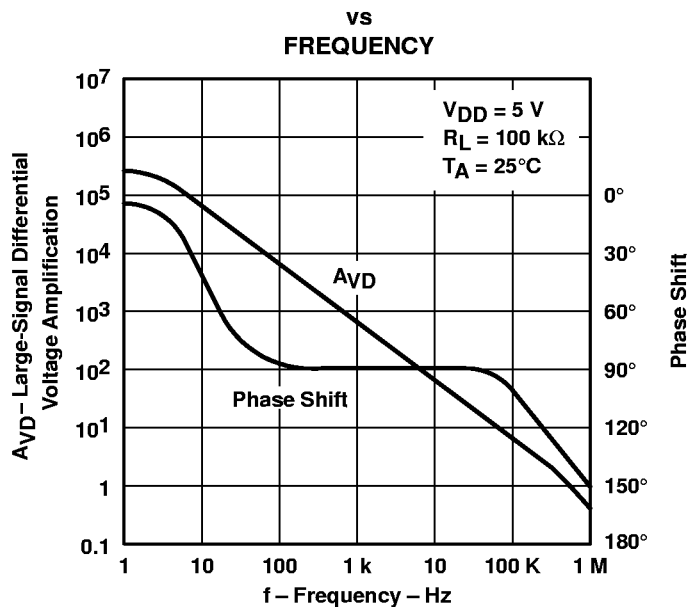

Figure 60

† Data at high and low temperatures are applicable only within the rated operating free-air temperature ranges of the various devices.

TYPICAL CHARACTERISTICS (MEDIUM-BIAS MODE)†

LARGE-SIGNAL DIFFERENTIAL VOLTAGE
 AMPLIFICATION AND PHASE SHIFT
 vs
 FREQUENCY

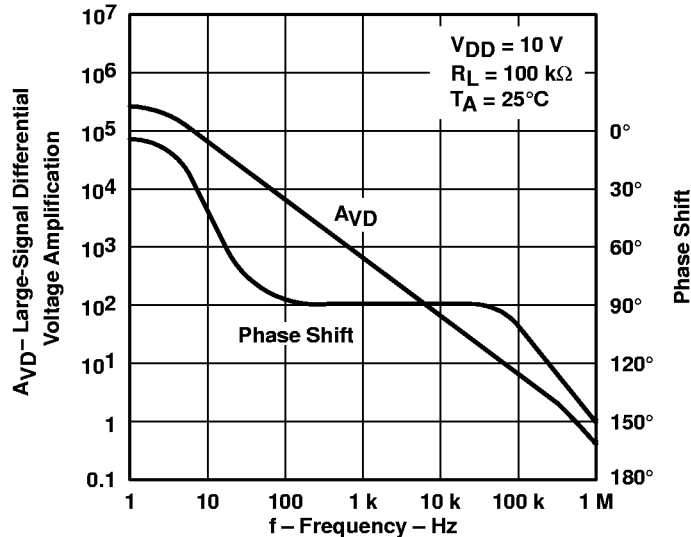

Figure 61

PHASE MARGIN
 vs
 SUPPLY VOLTAGE

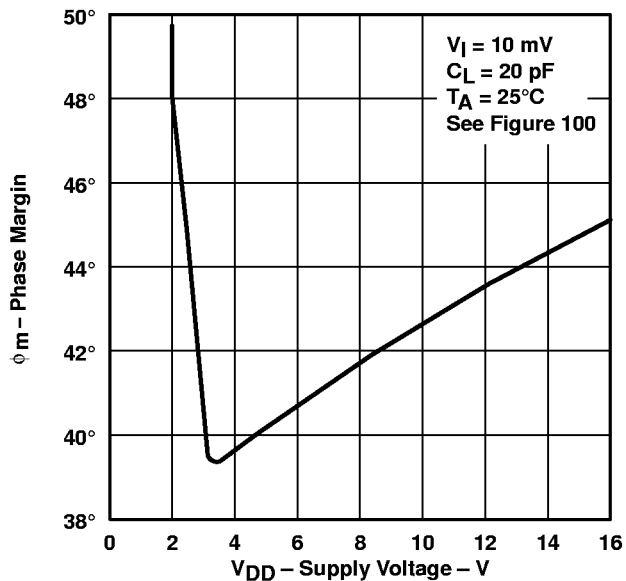

Figure 62

PHASE MARGIN
 vs
 FREE-AIR TEMPERATURE

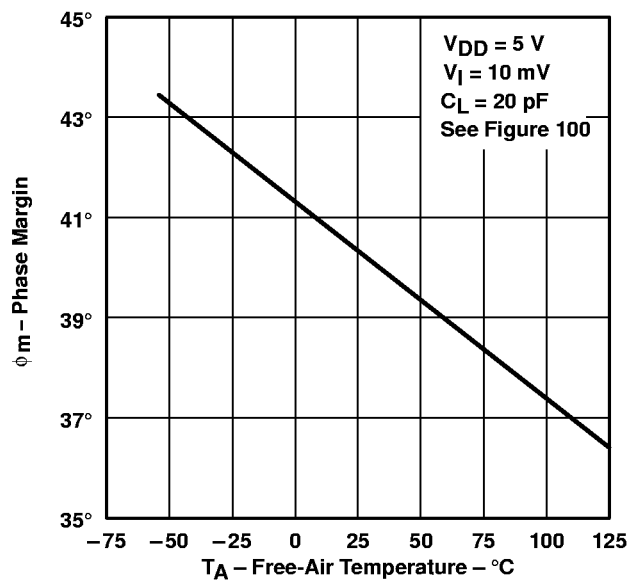

Figure 63

† Data at high and low temperatures are applicable only within the rated operating free-air temperature ranges of the various devices.

TYPICAL CHARACTERISTICS (MEDIUM-BIAS MODE)†

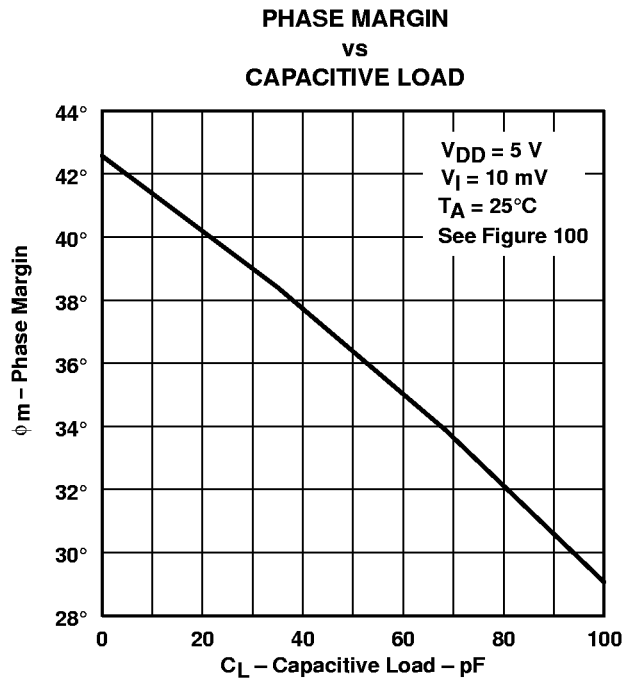

Figure 64

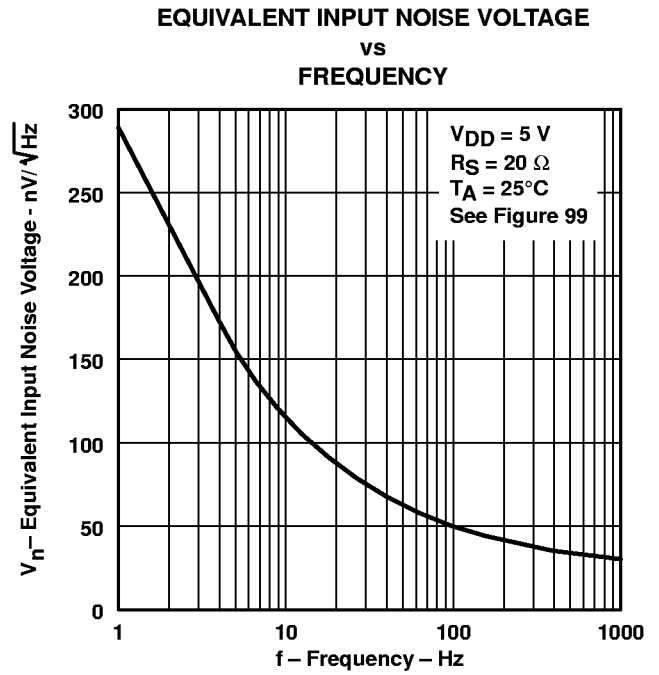

Figure 65

† Data at high and low temperatures are applicable only within the rated operating free-air temperature ranges of the various devices.

TLC271, TLC271A, TLC271B
LinCMOS™ PROGRAMMABLE LOW-POWER
OPERATIONAL AMPLIFIERS

SLOS090C – NOVEMBER 1987 – REVISED AUGUST 1997

LOW-BIAS MODE

electrical characteristics at specified free-air temperature (unless otherwise noted)

| PARAMETER | | TEST CONDITIONS | T _A † | TLC271C, TLC271AC, TLC271BC | | | | | | UNIT |
|---------------------|--|--|------------------|-----------------------------|-------------|-----|------------------------|-------------|-----|-------|
| | | | | V _{DD} = 5 V | | | V _{DD} = 10 V | | | |
| | | | | MIN | TYP | MAX | MIN | TYP | MAX | |
| V _{IO} | Input offset voltage | V _O = 1.4 V, V _{IC} = 0 V, R _S = 50 Ω, R _I = 1 MΩ | 25°C | 1.1 | | 10 | 1.1 | | 10 | mV |
| | | | Full range | | | 12 | | | 12 | |
| | | | 25°C | 0.9 | | 5 | 0.9 | | 5 | |
| | | | Full range | | | 6.5 | | | 6.5 | |
| | | | 25°C | 0.24 | | 2 | 0.26 | | 2 | |
| | | | Full range | | | 3 | | | 3 | |
| α _{VIO} | Average temperature coefficient of input offset voltage | | 25°C to 70°C | 1.1 | | | 1 | | | μV/°C |
| I _{IO} | Input offset current (see Note 4) | V _O = V _{DD} /2, V _{IC} = V _{DD} /2 | 25°C | 0.1 | | | 0.1 | | | pA |
| | | | 70°C | 7 | | 300 | 8 | | 300 | |
| I _{IB} | Input bias current (see Note 4) | V _O = V _{DD} /2, V _{IC} = V _{DD} /2 | 25°C | 0.6 | | | 0.7 | | | pA |
| | | | 70°C | 40 | | 600 | 50 | | 600 | |
| V _{ICR} | Common-mode input voltage range (see Note 5) | | 25°C | -0.2 to 4 | -0.3 to 4.2 | | -0.2 to 9 | -0.3 to 9.2 | | V |
| | | | Full range | -0.2 to 3.5 | | | -0.2 to 8.5 | | | V |
| V _{OH} | High-level output voltage | V _{ID} = 100 mV, R _L = 1 MΩ | 25°C | 3.2 | 4.1 | | 8 | 8.9 | | V |
| | | | 0°C | 3 | 4.1 | | 7.8 | 8.9 | | |
| | | | 70°C | 3 | 4.2 | | 7.8 | 8.9 | | |
| V _{OL} | Low-level output voltage | V _{ID} = -100 mV, I _{OL} = 0 | 25°C | 0 | | 50 | 0 | | 50 | mV |
| | | | 0°C | 0 | | 50 | 0 | | 50 | |
| | | | 70°C | 0 | | 50 | 0 | | 50 | |
| A _{VD} | Large-signal differential voltage amplification | R _L = 1 MΩ, See Note 6 | 25°C | 50 | 520 | | 50 | 870 | | V/mV |
| | | | 0°C | 50 | 700 | | 50 | 1030 | | |
| | | | 70°C | 50 | 380 | | 50 | 660 | | |
| CMRR | Common-mode rejection ratio | V _{IC} = V _{ICRmin} | 25°C | 65 | 94 | | 65 | 97 | | dB |
| | | | 0°C | 60 | 95 | | 60 | 97 | | |
| | | | 70°C | 60 | 95 | | 60 | 97 | | |
| k _{SVR} | Supply-voltage rejection ratio (ΔV _{DD} /ΔV _{IO}) | V _{DD} = 5 V to 10 V V _O = 1.4 V | 25°C | 70 | 97 | | 70 | 97 | | dB |
| | | | 0°C | 60 | 97 | | 60 | 97 | | |
| | | | 70°C | 60 | 98 | | 60 | 98 | | |
| I _{I(SEL)} | Input current (BIAS SELECT) | V _{I(SEL)} = V _{DD} | 25°C | 65 | | | 95 | | | nA |
| I _{DD} | Supply current | V _O = V _{DD} /2, V _{IC} = V _{DD} /2, No load | 25°C | 10 | | 17 | 14 | | 23 | μA |
| | | | 0°C | 12 | | 21 | 18 | | 33 | |
| | | | 70°C | 8 | | 14 | 11 | | 20 | |

† Full range is 0°C to 70°C.

- NOTES: 4. The typical values of input bias current and input offset current below 5 pA were determined mathematically.
5. This range also applies to each input individually.
6. At V_{DD} = 5 V, V_O = 0.25 V to 2 V; at V_{DD} = 10 V, V_O = 1 V to 6 V.



LOW-BIAS MODE

electrical characteristics at specified free-air temperature (unless otherwise noted)

| PARAMETER | | TEST CONDITIONS | T _A † | TLC271I, TLC271AI, TLC271BI | | | | | | UNIT | |
|---------------------|--|--|------------------|-----------------------------------|--|-----------|------------------------|------|-------|------|----|
| | | | | V _{DD} = 5 V | | | V _{DD} = 10 V | | | | |
| | | | | MIN | TYP | MAX | MIN | TYP | MAX | | |
| V _{IO} | Input offset voltage | V _O = 1.4 V, V _{IC} = 0 V, R _S = 50 Ω, R _L = 1 MΩ | 25°C | 1.1 | | 10 | 1.1 | | 10 | mV | |
| | | | Full range | | | | 13 | | | | |
| | | | 25°C | 0.9 | | 5 | 0.9 | | 5 | | |
| | | | Full range | | | | 7 | | | | |
| α _{VIO} | Average temperature coefficient of input offset voltage | | 25°C to 85°C | 1.1 | | 1 | | | μV/°C | | |
| | | | I _{IO} | Input offset current (see Note 4) | V _O = V _{DD} /2, V _{IC} = V _{DD} /2 | 25°C | 0.1 | | 0.1 | | pA |
| | | | | | | 85°C | 24 | 1000 | 26 | 1000 | |
| | | | I _{IB} | Input bias current (see Note 4) | V _O = V _{DD} /2, V _{IC} = V _{DD} /2 | 25°C | 0.6 | | 0.7 | | pA |
| 85°C | 200 | 2000 | | | | 220 | 2000 | | | | |
| V _{ICR} | Common-mode input voltage range (see Note 5) | | 25°C | -0.2 to 4 | -0.3 to 4.2 | -0.2 to 9 | -0.3 to 9.2 | V | | | |
| | | | Full range | -0.2 to 3.5 | -0.2 to 8.5 | | | V | | | |
| V _{OH} | High-level output voltage | V _{ID} = 100 mV, R _L = 1 MΩ | 25°C | 3 | 4.1 | 8 | 8.9 | V | | | |
| | | | -40°C | 3 | 4.1 | 7.8 | 8.9 | | | | |
| | | | 85°C | 3 | 4.2 | 7.8 | 8.9 | | | | |
| V _{OL} | Low-level output voltage | V _{ID} = -100 mV, I _{OL} = 0 | 25°C | 0 | | 50 | 0 | | mV | | |
| | | | -40°C | 0 | | 50 | 0 | | | | |
| | | | 85°C | 0 | | 50 | 0 | | | | |
| A _{VD} | Large-signal differential voltage amplification | R _L = 1 MΩ See Note 6 | 25°C | 50 | 520 | 50 | 870 | V/mV | | | |
| | | | -40°C | 50 | 900 | 50 | 1550 | | | | |
| | | | 85°C | 50 | 330 | 50 | 585 | | | | |
| CMRR | Common-mode rejection ratio | V _{IC} = V _{ICRmin} | 25°C | 65 | 94 | 65 | 97 | dB | | | |
| | | | -40°C | 60 | 95 | 60 | 97 | | | | |
| | | | 85°C | 60 | 95 | 60 | 98 | | | | |
| k _{SVR} | Supply-voltage rejection ratio (ΔV _{DD} /ΔV _{IO}) | V _{DD} = 5 V to 10 V V _O = 1.4 V | 25°C | 70 | 97 | 70 | 97 | dB | | | |
| | | | -40°C | 60 | 97 | 60 | 97 | | | | |
| | | | 85°C | 60 | 98 | 60 | 98 | | | | |
| I _{I(SEL)} | Input current (BIAS SELECT) | V _{I(SEL)} = V _{DD} | 25°C | 65 | | 95 | | nA | | | |
| I _{DD} | Supply current | V _O = V _{DD} /2, V _{IC} = V _{DD} /2, No load | 25°C | 10 | 17 | 14 | 23 | μA | | | |
| | | | -40°C | 16 | | 27 | 25 | | 43 | | |
| | | | 85°C | 17 | | 13 | 10 | | 18 | | |

† Full range is -40 to 85°C.

- NOTES:
4. The typical values of input bias current and input offset current below 5 pA were determined mathematically.
 5. This range also applies to each input individually.
 6. At V_{DD} = 5 V, V_O = 0.25 V to 2 V; at V_{DD} = 10 V, V_O = 1 V to 6 V.

TLC271, TLC271A, TLC271B
LinCMOS™ PROGRAMMABLE LOW-POWER
OPERATIONAL AMPLIFIERS

SLOS090C – NOVEMBER 1987 – REVISED AUGUST 1997

LOW-BIAS MODE

electrical characteristics at specified free-air temperature (unless otherwise noted)

| PARAMETER | TEST CONDITIONS | T _A † | TLC271M | | | | | | UNIT |
|---|--|------------------|-----------------------|-------------|-----|------------------------|-------------|-----|-------|
| | | | V _{DD} = 5 V | | | V _{DD} = 10 V | | | |
| | | | MIN | TYP | MAX | MIN | TYP | MAX | |
| V _{IO} Input offset voltage | V _O = 1.4 V, V _{IC} = 0 V, R _S = 50 Ω, R _L = 1 MΩ | 25°C | | 1.1 | 10 | | 1.1 | 10 | mV |
| | | Full range | | | 12 | | | 12 | |
| α _{VIO} Average temperature coefficient of input offset voltage | | 25°C to 125°C | | 1.4 | | | 1.4 | | μV/°C |
| I _{IO} Input offset current (see Note 4) | V _O = V _{DD} /2, V _{IC} = V _{DD} /2 | 25°C | | 0.1 | | | 0.1 | | pA |
| | | 125°C | | 1.4 | 15 | | 1.8 | 15 | nA |
| I _{IB} Input bias current (see Note 4) | V _O = V _{DD} /2, V _{IC} = V _{DD} /2 | 25°C | | 0.6 | | | 0.7 | | pA |
| | | 125°C | | 9 | 35 | | 10 | 35 | nA |
| V _{ICR} Common-mode input voltage range (see Note 5) | | 25°C | 0 to 4 | -0.3 to 4.2 | | 0 to 9 | -0.3 to 9.2 | | V |
| | | Full range | 0 to 3.5 | | | 0 to 8.5 | | | V |
| V _{OH} High-level output voltage | V _{ID} = 100 mV, R _L = 1 MΩ | 25°C | 3.2 | 4.1 | | 8 | 8.9 | | V |
| | | -55°C | 3 | 4.1 | | 7.8 | 8.8 | | |
| | | 125°C | 3 | 4.2 | | 7.8 | 9 | | |
| V _{OL} Low-level output voltage | V _{ID} = -100 mV, I _{OL} = 0 | 25°C | | 0 | 50 | | 0 | 50 | mV |
| | | -55°C | | 0 | 50 | | 0 | 50 | |
| | | 125°C | | 0 | 50 | | 0 | 50 | |
| A _{VD} Large-signal differential voltage amplification | R _L = 1 MΩ, See Note 6 | 25°C | 50 | 520 | | 50 | 870 | | V/mV |
| | | -55°C | 25 | 1000 | | 25 | 1775 | | |
| | | 125°C | 25 | 200 | | 25 | 380 | | |
| CMRR Common-mode rejection ratio | V _{IC} = V _{ICRmin} | 25°C | 65 | 94 | | 65 | 97 | | dB |
| | | -55°C | 60 | 95 | | 60 | 97 | | |
| | | 125°C | 60 | 85 | | 60 | 91 | | |
| k _{SVR} Supply-voltage rejection ratio (ΔV _{DD} /ΔV _{IO}) | V _{DD} = 5 V to 10 V V _O = 1.4 V | 25°C | 70 | 97 | | 70 | 97 | | dB |
| | | -55°C | 60 | 97 | | 60 | 97 | | |
| | | 125°C | 60 | 98 | | 60 | 98 | | |
| I _{I(SEL)} Input current (BIAS SELECT) | V _{I(SEL)} = V _{DD} | 25°C | | 65 | | | 95 | | nA |
| I _{DD} Supply current | V _O = V _{DD} /2, V _{IC} = V _{DD} /2, No load | 25°C | | 10 | 17 | | 14 | 23 | μA |
| | | -55°C | | 17 | 30 | | 28 | 48 | |
| | | 125°C | | 7 | 12 | | 9 | 15 | |

† Full range is -55°C to 125°C.

NOTES: 4. The typical values of input bias current and input offset current below 5 pA were determined mathematically.

5. This range also applies to each input individually.

6. At V_{DD} = 5 V, V_O = 0.25 V to 2 V; at V_{DD} = 10 V, V_O = 1 V to 6 V.



LOW-BIAS MODE

operating characteristics at specified free-air temperature, $V_{DD} = 5\text{ V}$

| PARAMETER | TEST CONDITIONS | T_A | TLC271C, TLC271AC, TLC271BC | | | UNIT |
|---|---|--------------------------------|-----------------------------|------|------------------------|------------|
| | | | MIN | TYP | MAX | |
| SR Slew rate at unity gain | $R_L = 1\text{ M}\Omega$, $C_L = 20\text{ pF}$, See Figure 98 | $V_{I(PP)} = 1\text{ V}$ | 25°C | 0.03 | | V/ μ s |
| | | | 0°C | 0.04 | | |
| | | | 70°C | 0.03 | | |
| | | $V_{I(PP)} = 2.5\text{ V}$ | 25°C | 0.03 | | |
| | | | 0°C | 0.03 | | |
| | | | 70°C | 0.02 | | |
| V_n Equivalent input noise voltage | $f = 1\text{ kHz}$, See Figure 99 | $R_S = 20\ \Omega$, 25°C | 68 | | nV/ $\sqrt{\text{Hz}}$ | |
| B_{OM} Maximum output-swing bandwidth | $V_O = V_{OH}$, $R_L = 1\text{ M}\Omega$, $C_L = 20\text{ pF}$, See Figure 98 | 25°C | 5 | | kHz | |
| | | 0°C | 6 | | | |
| | | 70°C | 4.5 | | | |
| B_1 Unity-gain bandwidth | $V_I = 10\text{ mV}$, See Figure 100 | $C_L = 20\text{ pF}$, 25°C | 85 | | kHz | |
| | | | 0°C | 100 | | |
| | | | 70°C | 65 | | |
| ϕ_m Phase margin | $V_I = 10\text{ mV}$, $C_L = 20\text{ pF}$, | $f = B_1$, See Figure 100 | 25°C | 34° | | |
| | | | 0°C | 36° | | |
| | | | 70°C | 30° | | |

operating characteristics at specified free-air temperature, $V_{DD} = 10\text{ V}$

| PARAMETER | TEST CONDITIONS | T_A | TLC271C, TLC271AC, TLC271BC | | | UNIT |
|---|---|--------------------------------|-----------------------------|------|------------------------|------------|
| | | | MIN | TYP | MAX | |
| SR Slew rate at unity gain | $R_L = 1\text{ M}\Omega$, $C_L = 20\text{ pF}$, See Figure 98 | $V_{I(PP)} = 1\text{ V}$ | 25°C | 0.05 | | V/ μ s |
| | | | 0°C | 0.05 | | |
| | | | 70°C | 0.04 | | |
| | | $V_{I(PP)} = 5.5\text{ V}$ | 25°C | 0.04 | | |
| | | | 0°C | 0.05 | | |
| | | | 70°C | 0.04 | | |
| V_n Equivalent input noise voltage | $f = 1\text{ kHz}$, See Figure 99 | $R_S = 20\ \Omega$, 25°C | 68 | | nV/ $\sqrt{\text{Hz}}$ | |
| B_{OM} Maximum output-swing bandwidth | $V_O = V_{OH}$, $R_L = 1\text{ M}\Omega$, $C_L = 20\text{ pF}$, See Figure 98 | 25°C | 1 | | kHz | |
| | | 0°C | 1.3 | | | |
| | | 70°C | 0.9 | | | |
| B_1 Unity-gain bandwidth | $V_I = 10\text{ mV}$, See Figure 100 | $C_L = 20\text{ pF}$, 25°C | 110 | | kHz | |
| | | | 0°C | 125 | | |
| | | | 70°C | 90 | | |
| ϕ_m Phase margin | $V_I = 10\text{ mV}$, $C_L = 20\text{ pF}$, | $f = B_1$, See Figure 100 | 25°C | 38° | | |
| | | | 0°C | 40° | | |
| | | | 70°C | 34° | | |

TLC271, TLC271A, TLC271B
LinCMOS™ PROGRAMMABLE LOW-POWER
OPERATIONAL AMPLIFIERS

SLOS090C – NOVEMBER 1987 – REVISED AUGUST 1997

LOW-BIAS MODE

operating characteristics at specified free-air temperature, $V_{DD} = 5\text{ V}$

| PARAMETER | TEST CONDITIONS | T_A | TLC271I, TLC271AI, TLC271BI | | | UNIT |
|---|---|--------------------------------|--------------------------------|------|------------------------|------------|
| | | | MIN | TYP | MAX | |
| SR Slew rate at unity gain | $R_L = 1\text{ M}\Omega$, $C_L = 20\text{ pF}$, See Figure 98 | $V_{I(PP)} = 1\text{ V}$ | 25°C | 0.03 | | V/ μ s |
| | | | -40°C | 0.04 | | |
| | | | 85°C | 0.03 | | |
| | | $V_{I(PP)} = 2.5\text{ V}$ | 25°C | 0.03 | | |
| | | | -40°C | 0.04 | | |
| | | | 85°C | 0.02 | | |
| V_n Equivalent input noise voltage | $f = 1\text{ kHz}$, See Figure 99 | $R_S = 20\ \Omega$, 25°C | 68 | | nV/ $\sqrt{\text{Hz}}$ | |
| B_{OM} Maximum output-swing bandwidth | $V_O = V_{OH}$, $R_L = 1\text{ M}\Omega$, $C_L = 20\text{ pF}$, See Figure 98 | 25°C | 5 | | kHz | |
| | | -40°C | 7 | | | |
| | | 85°C | 4 | | | |
| B_1 Unity-gain bandwidth | $V_I = 10\text{ mV}$, See Figure 100 | $C_L = 20\text{ pF}$, 25°C | 85 | | MHz | |
| | | | -40°C | 130 | | |
| | | | 85°C | 55 | | |
| ϕ_m Phase margin | $V_I = 10\text{ mV}$, $C_L = 20\text{ pF}$, $f = B_1$, See Figure 100 | 25°C | 34° | | | |
| | | -40°C | 38° | | | |
| | | 85°C | 28° | | | |

operating characteristics at specified free-air temperature, $V_{DD} = 10\text{ V}$

| PARAMETER | TEST CONDITIONS | T_A | TLC271C, TLC271AC, TLC271BC | | | UNIT |
|---|---|--------------------------------|--------------------------------|------|------------------------|------------|
| | | | MIN | TYP | MAX | |
| SR Slew rate at unity gain | $R_L = 1\text{ M}\Omega$, $C_L = 20\text{ pF}$, See Figure 98 | $V_{I(PP)} = 1\text{ V}$ | 25°C | 0.05 | | V/ μ s |
| | | | -40°C | 0.06 | | |
| | | | 85°C | 0.03 | | |
| | | $V_{I(PP)} = 5.5\text{ V}$ | 25°C | 0.04 | | |
| | | | -40°C | 0.05 | | |
| | | | 85°C | 0.03 | | |
| V_n Equivalent input noise voltage | $f = 1\text{ kHz}$, See Figure 99 | $R_S = 20\ \Omega$, 25°C | 68 | | nV/ $\sqrt{\text{Hz}}$ | |
| B_{OM} Maximum output-swing bandwidth | $V_O = V_{OH}$, $R_L = 1\text{ M}\Omega$, $C_L = 20\text{ pF}$, See Figure 98 | 25°C | 1 | | kHz | |
| | | -40°C | 1.4 | | | |
| | | 85°C | 0.8 | | | |
| B_1 Unity-gain bandwidth | $V_I = 10\text{ mV}$, See Figure 100 | $C_L = 20\text{ pF}$, 25°C | 110 | | MHz | |
| | | | -40°C | 155 | | |
| | | | 85°C | 80 | | |
| ϕ_m Phase margin | $V_I = 10\text{ mV}$, $C_L = 20\text{ pF}$, $f = B_1$, See Figure 100 | 25°C | 38° | | | |
| | | -40°C | 42° | | | |
| | | 85°C | 32° | | | |



LOW-BIAS MODE

operating characteristics at specified free-air temperature, $V_{DD} = 5\text{ V}$

| PARAMETER | TEST CONDITIONS | T _A | TLC271M | | | UNIT |
|--|--|--|---------|------|--------|------|
| | | | MIN | TYP | MAX | |
| SR Slew rate at unity gain | R _L = 1 MΩ, C _L = 20 pF, See Figure 98 | V _{I(PP)} = 1 V | 25°C | 0.03 | | V/μs |
| | | | -55°C | 0.04 | | |
| | | | 125°C | 0.02 | | |
| | | V _{I(PP)} = 2.5 V | 25°C | 0.03 | | |
| | | | -55°C | 0.04 | | |
| | | | 125°C | 0.02 | | |
| V _n Equivalent input noise voltage | f = 1 kHz, See Figure 99 | R _S = 20 Ω, 25°C | 68 | | nV/√Hz | |
| B _{OM} Maximum output-swing bandwidth | V _O = V _{OH} , R _L = 1 MΩ, | C _L = 20 pF, See Figure 98 | 25°C | 5 | | kHz |
| | | | -55°C | 8 | | |
| | | | 125°C | 3 | | |
| B ₁ Unity-gain bandwidth | V _I = 10 mV, See Figure 100 | C _L = 20 pF, | 25°C | 85 | | kHz |
| | | | -55°C | 140 | | |
| | | | 125°C | 45 | | |
| φ _m Phase margin | V _I = 10 mV, C _L = 20 pF, | f = B ₁ , See Figure 100 | 25°C | 34° | | |
| | | | -55°C | 39° | | |
| | | | 125°C | 25° | | |

operating characteristics at specified free-air temperature, $V_{DD} = 10\text{ V}$

| PARAMETER | TEST CONDITIONS | T _A | TLC271M | | | UNIT |
|--|--|--|---------|------|--------|------|
| | | | MIN | TYP | MAX | |
| SR Slew rate at unity gain | R _L = 1 MΩ, C _L = 20 pF, See Figure 98 | V _{I(PP)} = 1 V | 25°C | 0.05 | | V/μs |
| | | | -55°C | 0.06 | | |
| | | | 125°C | 0.03 | | |
| | | V _{I(PP)} = 5.5 V | 25°C | 0.04 | | |
| | | | -55°C | 0.06 | | |
| | | | 125°C | 0.03 | | |
| V _n Equivalent input noise voltage | f = 1 kHz, See Figure 99 | R _S = 20 Ω, 25°C | 68 | | nV/√Hz | |
| B _{OM} Maximum output-swing bandwidth | V _O = V _{OH} , R _L = 1 MΩ, | C _L = 20 pF, See Figure 98 | 25°C | 1 | | kHz |
| | | | -55°C | 1.5 | | |
| | | | 125°C | 0.7 | | |
| B ₁ Unity-gain bandwidth | V _I = 10 mV, See Figure 100 | C _L = 20 pF, | 25°C | 110 | | kHz |
| | | | -55°C | 165 | | |
| | | | 125°C | 70 | | |
| φ _m Phase margin | V _I = 10 mV, C _L = 20 pF, | f = B ₁ , See Figure 100 | 25°C | 38° | | |
| | | | -55°C | 43° | | |
| | | | 125°C | 29° | | |

TLC271, TLC271A, TLC271B
LinCMOS™ PROGRAMMABLE LOW-POWER
OPERATIONAL AMPLIFIERS

SLOS090C – NOVEMBER 1987 – REVISED AUGUST 1997

TYPICAL CHARACTERISTICS (LOW-BIAS MODE)

Table of Graphs

| | | | FIGURE |
|----------------|---|---|------------------------------|
| V_{IO} | Input offset voltage | Distribution | 66, 67 |
| α_{VIO} | Temperature coefficient | Distribution | 68, 69 |
| V_{OH} | High-level output voltage | vs High-level output current vs Supply voltage vs Free-air temperature | 70, 71 72 73 |
| V_{OL} | Low-level output voltage | vs Common-mode input voltage vs Differential input voltage vs Free-air temperature vs Low-level output current | 74, 75 76 77 78, 79 |
| A_{VD} | Large-signal differential voltage amplification | vs Supply voltage vs Free-air temperature vs Frequency | 80 81 92, 93 |
| I_{IB} | Input bias current | vs Free-air temperature | 82 |
| I_{IO} | Input offset current | vs Free-air temperature | 82 |
| V_I | Maximum input voltage | vs Supply voltage | 83 |
| I_{DD} | Supply current | vs Supply voltage vs Free-air temperature | 84 85 |
| SR | Slew rate | vs Supply voltage vs Free-air temperature | 86 87 |
| | Bias-select current | vs Supply voltage | 88 |
| $V_{O(PP)}$ | Maximum peak-to-peak output voltage | vs Frequency | 89 |
| B_1 | Unity-gain bandwidth | vs Free-air temperature vs Supply voltage | 90 91 |
| ϕ_m | Phase margin | vs Supply voltage vs Free-air temperature vs Capacitive load | 94 95 96 |
| V_n | Equivalent input noise voltage | vs Frequency | 97 |
| | Phase shift | vs Frequency | 92, 93 |



TYPICAL CHARACTERISTICS (LOW-BIAS MODE)†

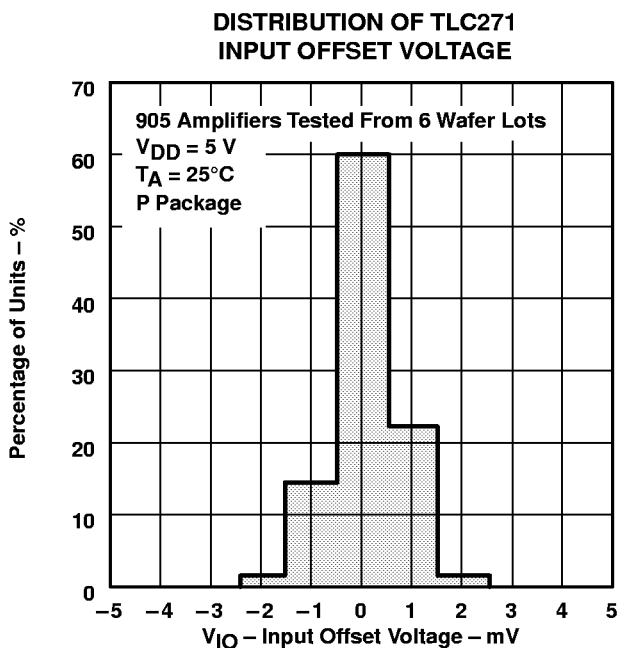

Figure 66

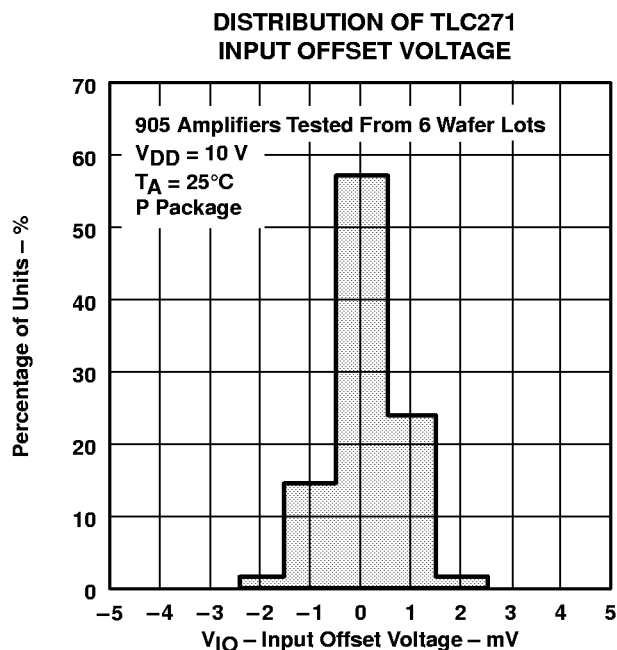

Figure 67

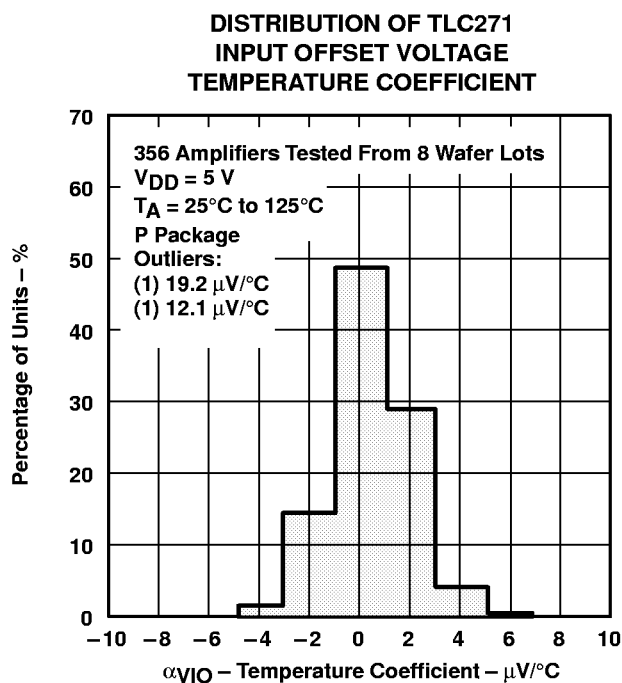

Figure 68

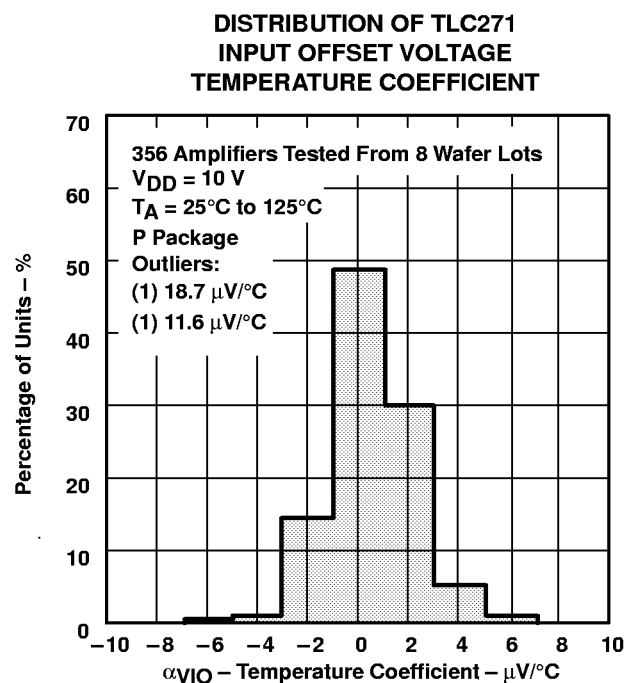

Figure 69

† Data at high and low temperatures are applicable only within the rated operating free-air temperature ranges of the various devices.

TYPICAL CHARACTERISTICS (LOW-BIAS MODE)†

HIGH-LEVEL OUTPUT VOLTAGE
 vs
 HIGH-LEVEL OUTPUT CURRENT

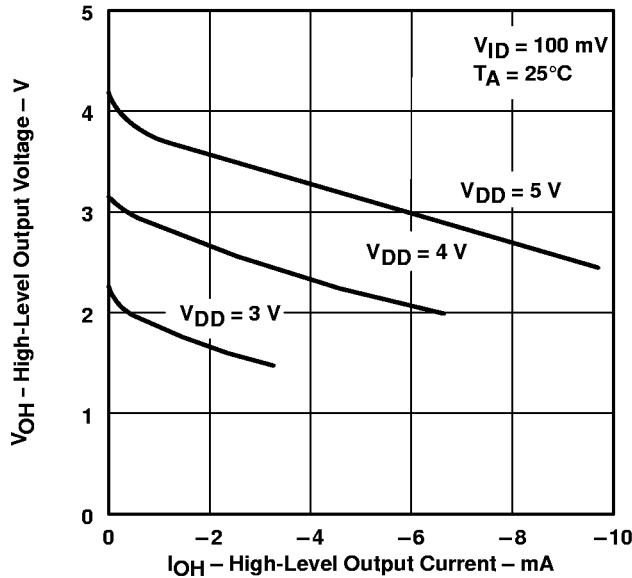

Figure 70

HIGH-LEVEL OUTPUT VOLTAGE
 vs
 HIGH-LEVEL OUTPUT CURRENT

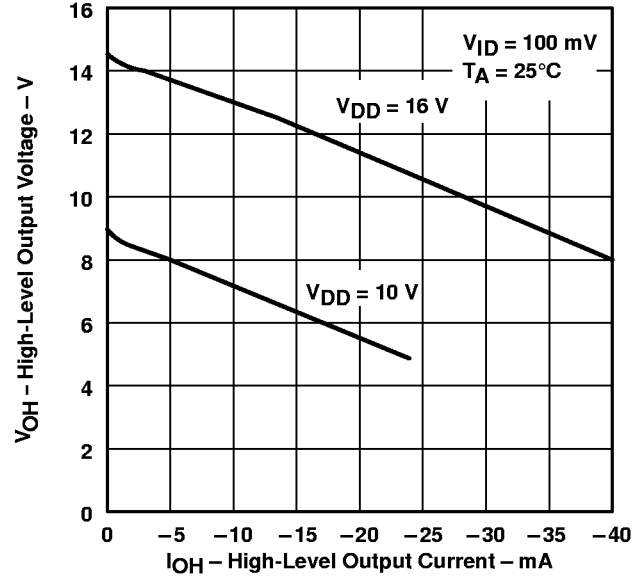

Figure 71

HIGH-LEVEL OUTPUT VOLTAGE
 vs
 SUPPLY VOLTAGE

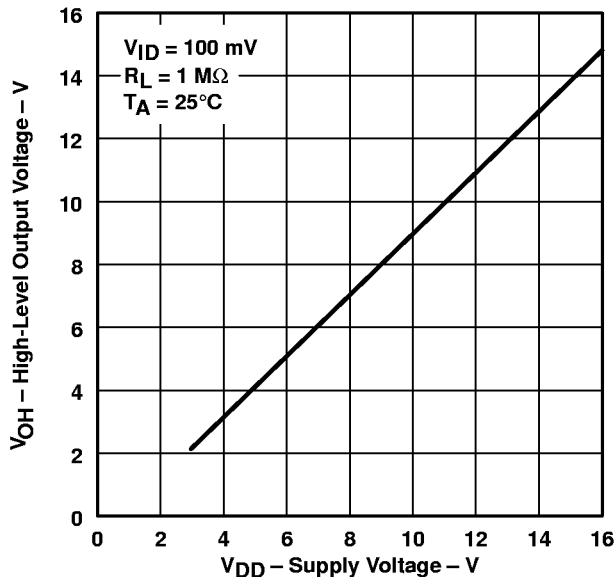

Figure 72

HIGH-LEVEL OUTPUT VOLTAGE
 vs
 FREE-AIR TEMPERATURE

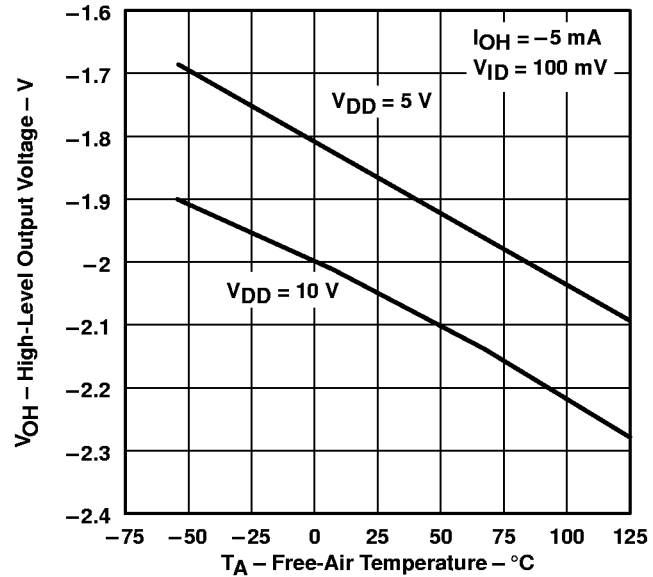

Figure 73

† Data at high and low temperatures are applicable only within the rated operating free-air temperature ranges of the various devices.

TYPICAL CHARACTERISTICS (LOW-BIAS MODE)†

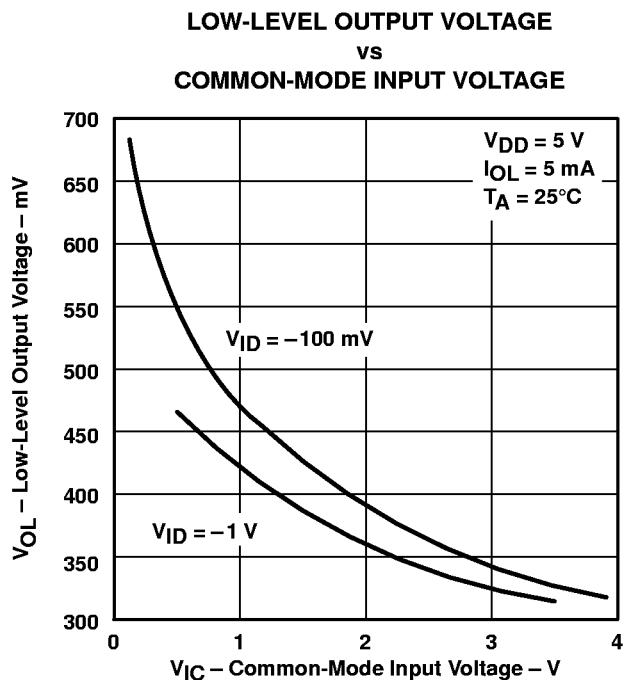

Figure 74

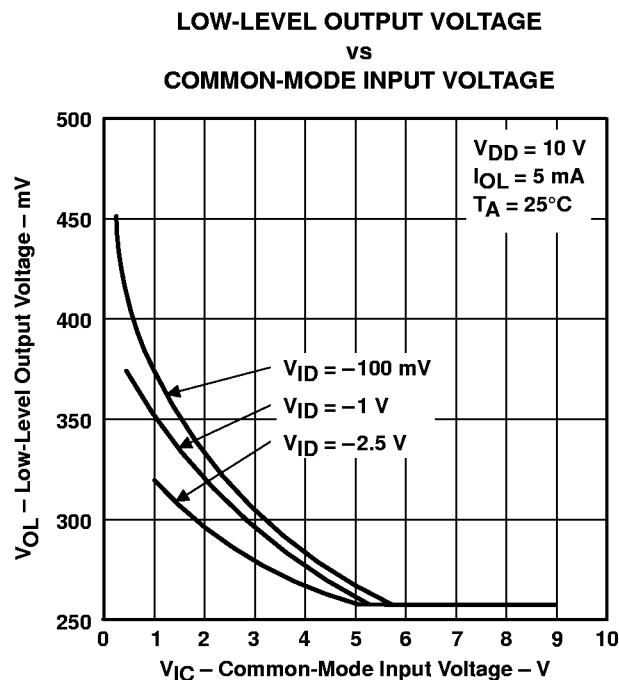

Figure 75

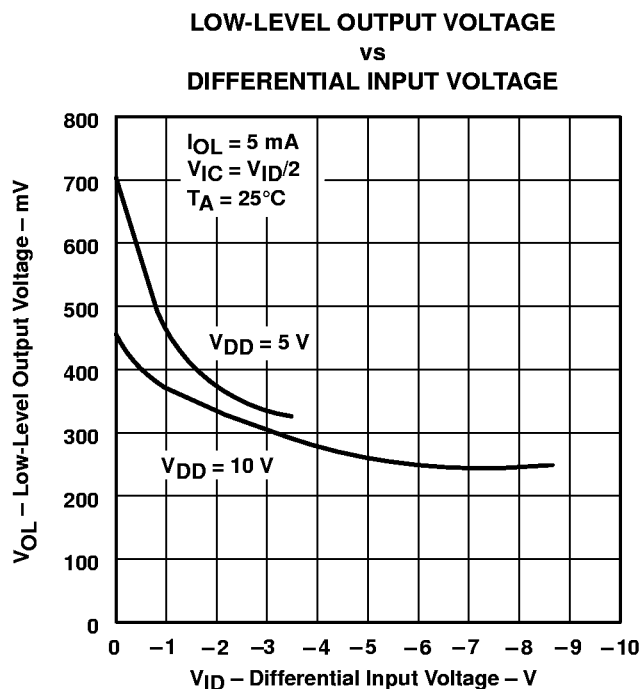

Figure 76

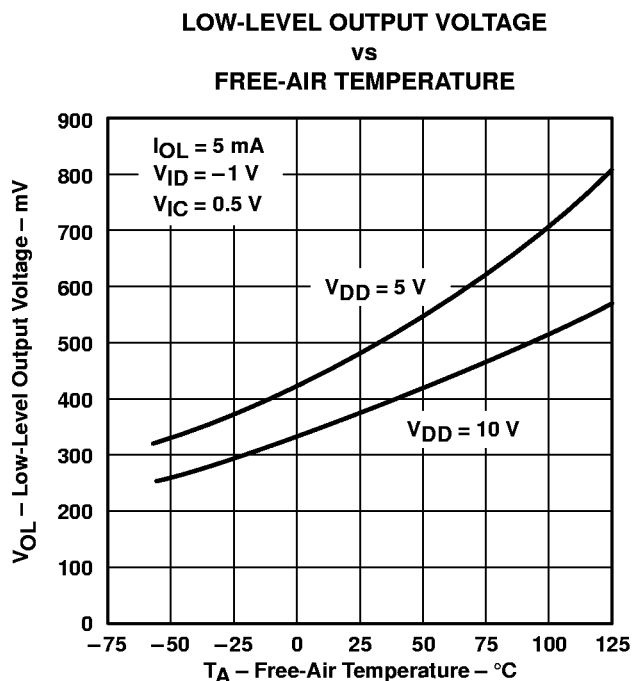

Figure 77

† Data at high and low temperatures are applicable only within the rated operating free-air temperature ranges of the various devices.

TYPICAL CHARACTERISTICS (LOW-BIAS MODE)†

LOW-LEVEL OUTPUT VOLTAGE
 vs
 LOW-LEVEL OUTPUT CURRENT

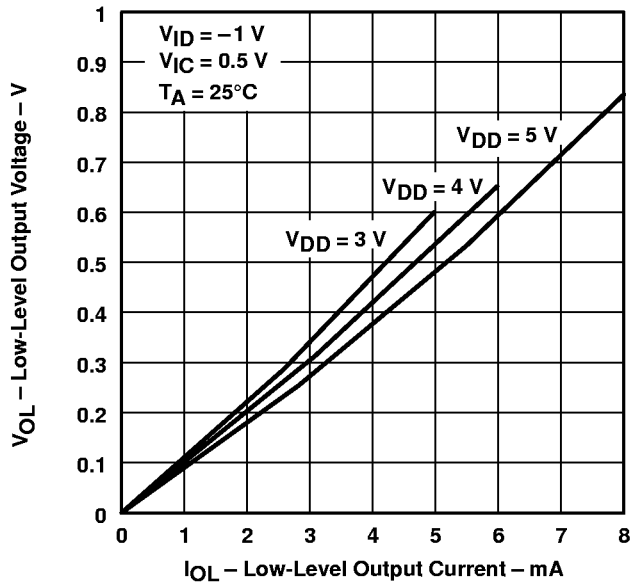

Figure 78

LOW-LEVEL OUTPUT VOLTAGE
 vs
 LOW-LEVEL OUTPUT CURRENT

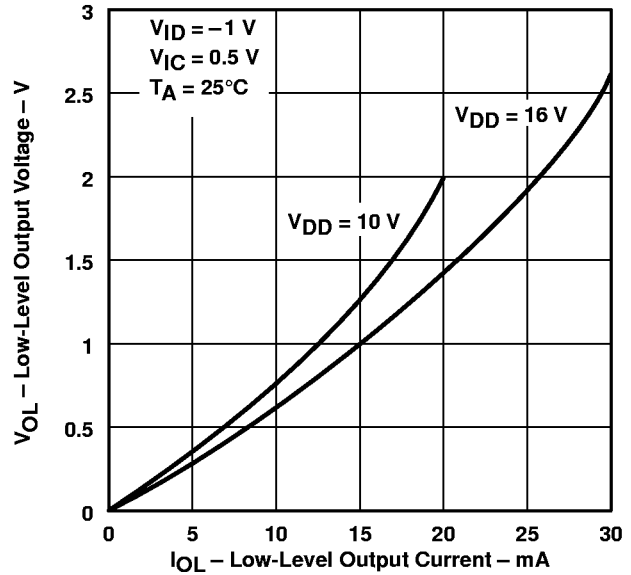

Figure 79

LARGE-SIGNAL
 DIFFERENTIAL VOLTAGE AMPLIFICATION
 vs
 SUPPLY VOLTAGE

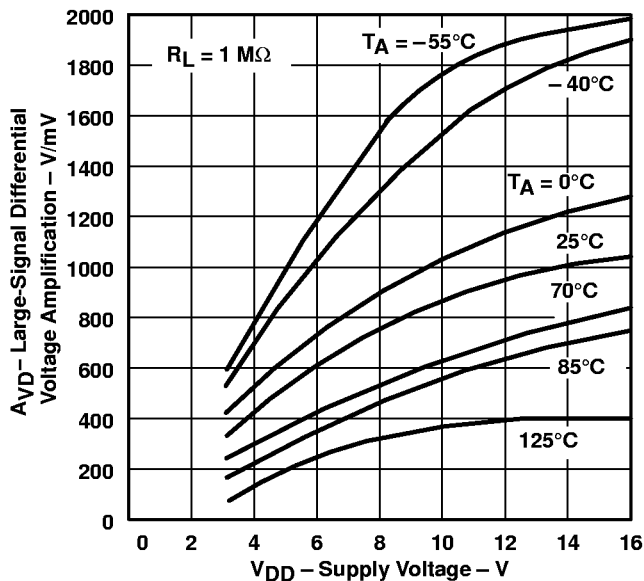

Figure 80

LARGE-SIGNAL
 DIFFERENTIAL VOLTAGE AMPLIFICATION
 vs
 FREE-AIR TEMPERATURE

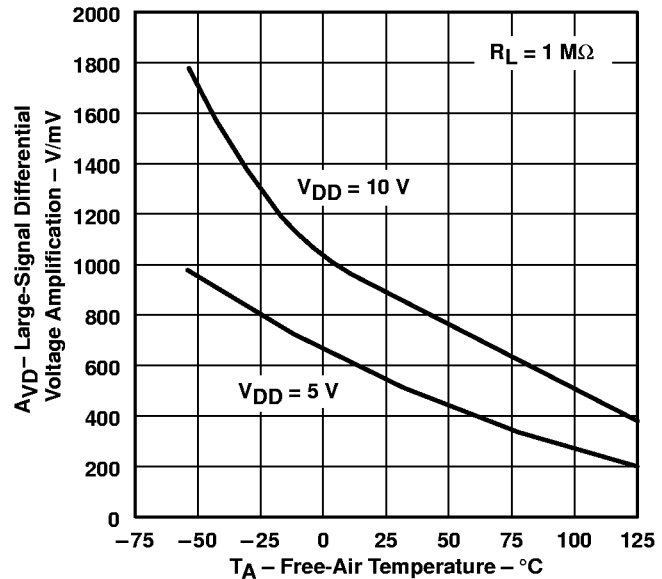
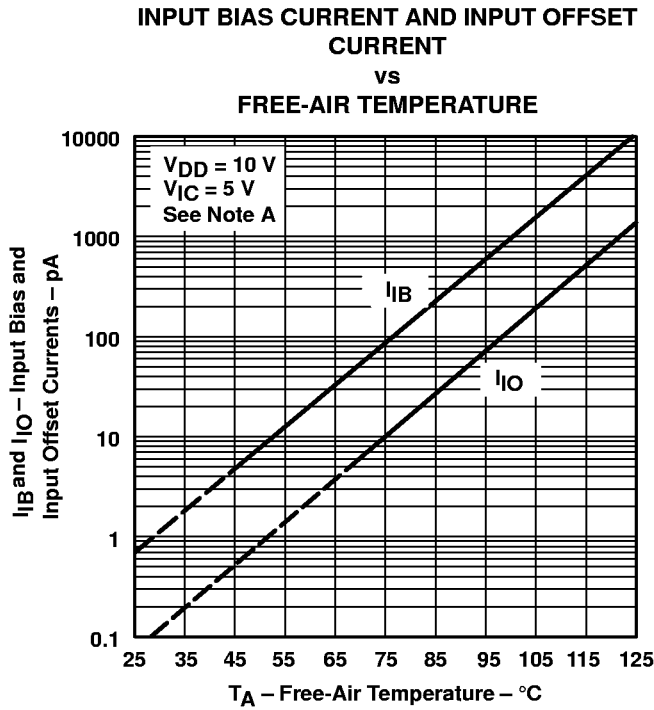

Figure 81

† Data at high and low temperatures are applicable only within the rated operating free-air temperature ranges of the various devices.

TYPICAL CHARACTERISTICS (LOW-BIAS MODE)†



NOTE A: The typical values of input bias current and input offset current below 5 pA were determined mathematically.

Figure 82

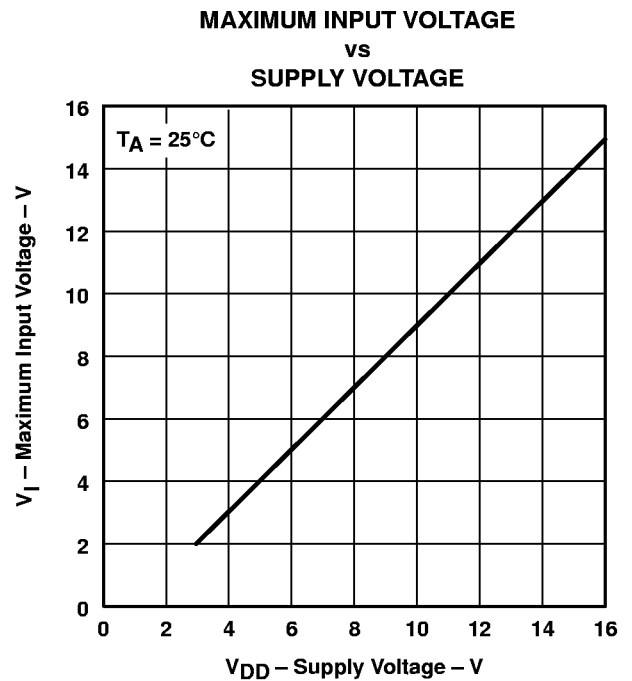

Figure 83

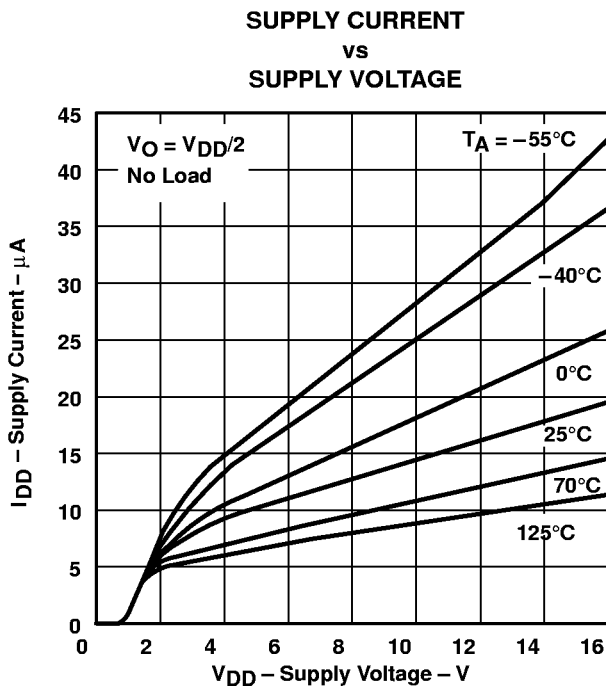

Figure 84

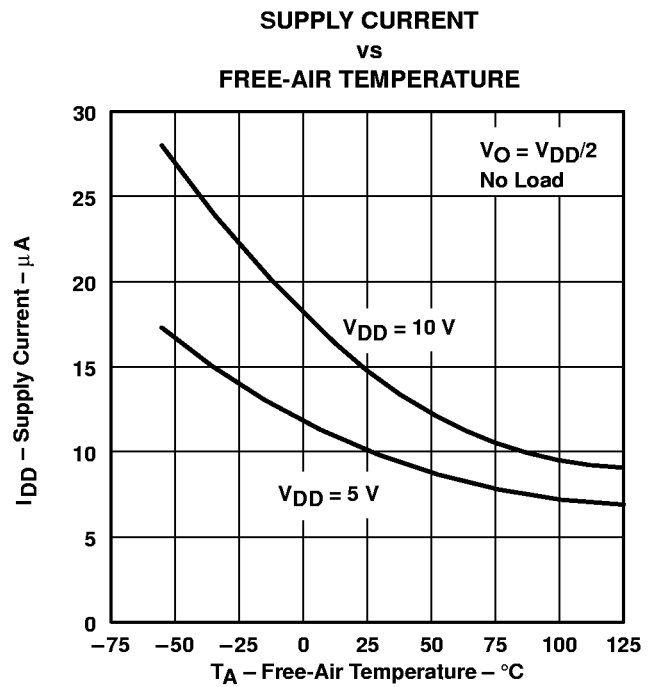

Figure 85

† Data at high and low temperatures are applicable only within the rated operating free-air temperature ranges of the various devices.

TYPICAL CHARACTERISTICS (LOW-BIAS MODE)†

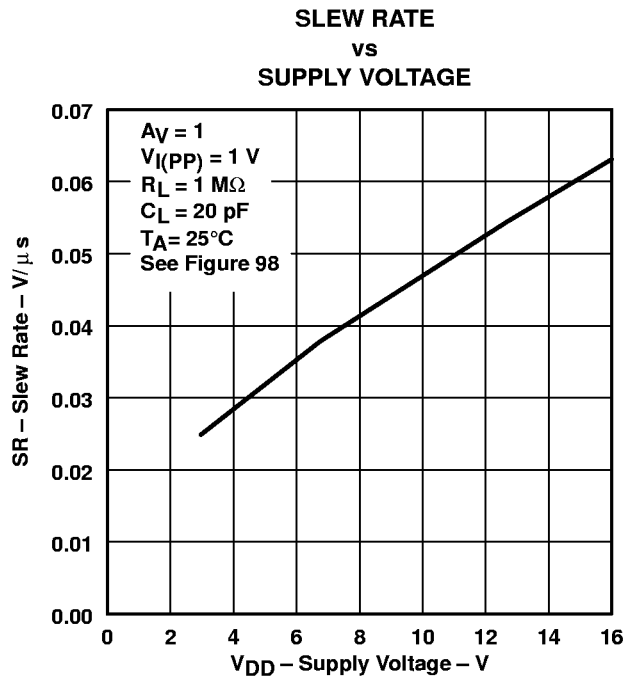

Figure 86

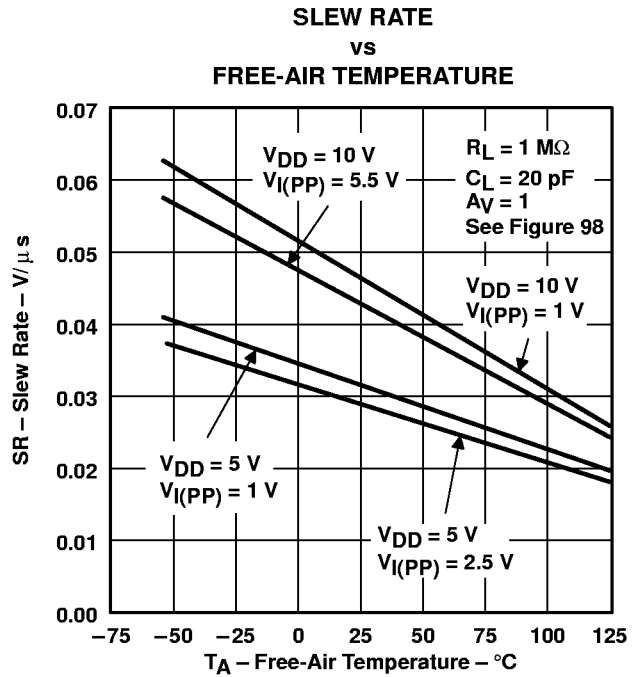

Figure 87

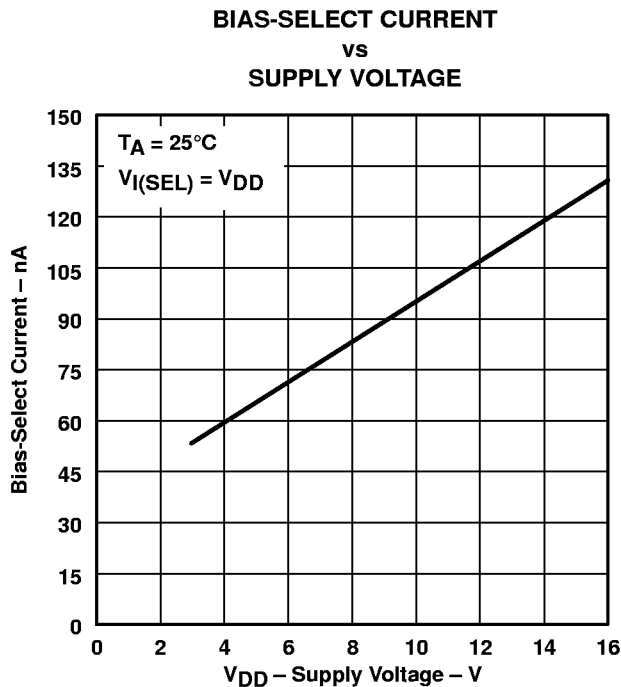

Figure 88

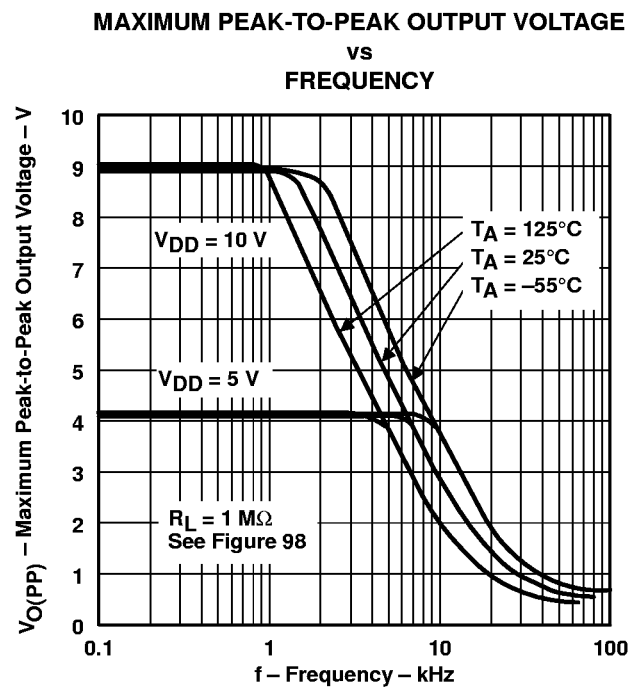

Figure 89

† Data at high and low temperatures are applicable only within the rated operating free-air temperature ranges of the various devices.

TYPICAL CHARACTERISTICS (LOW-BIAS MODE)†

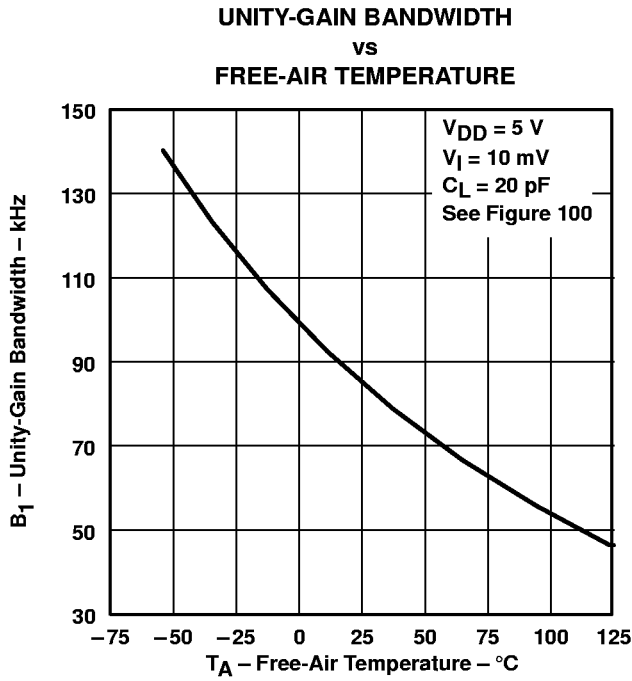

Figure 90

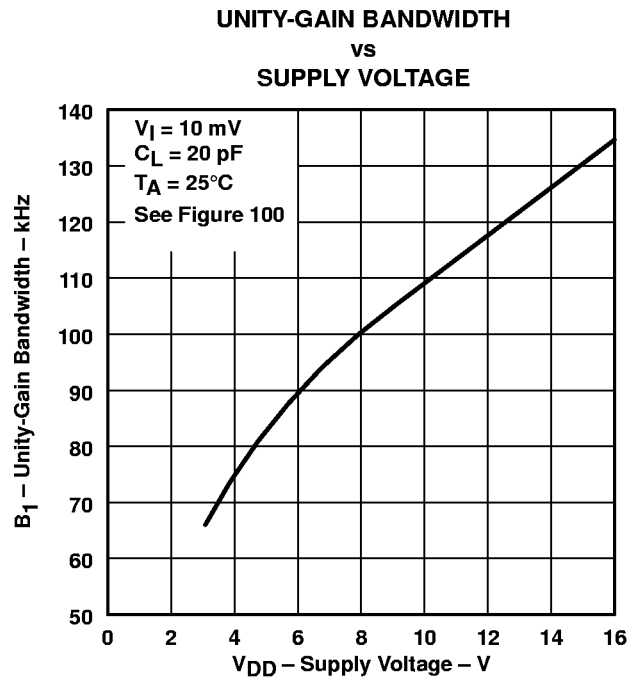

Figure 91

**LARGE-SIGNAL DIFFERENTIAL VOLTAGE
AMPLIFICATION AND PHASE SHIFT
vs
FREQUENCY**

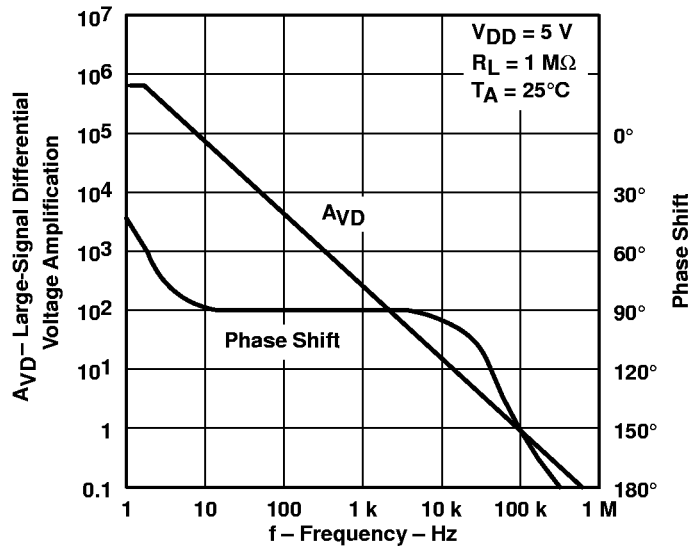

Figure 92

† Data at high and low temperatures are applicable only within the rated operating free-air temperature ranges of the various devices.

TYPICAL CHARACTERISTICS (LOW-BIAS MODE)†

LARGE-SIGNAL DIFFERENTIAL VOLTAGE
 AMPLIFICATION AND PHASE SHIFT
 vs
 FREQUENCY

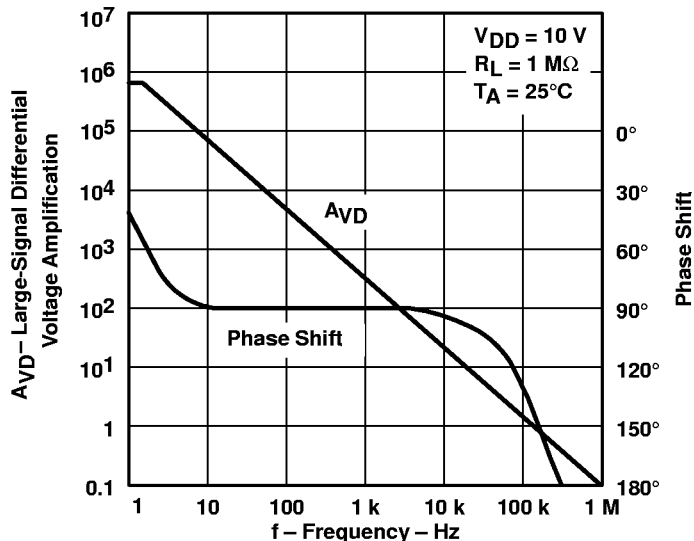

Figure 93

PHASE MARGIN
 vs
 SUPPLY VOLTAGE

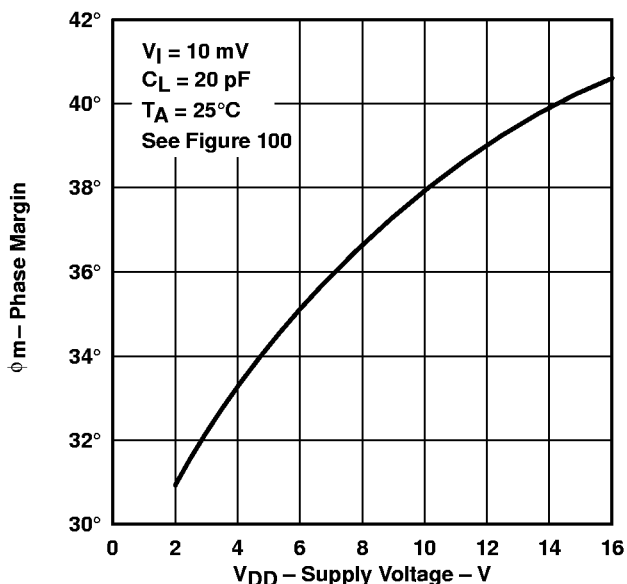

Figure 94

PHASE MARGIN
 vs
 FREE-AIR TEMPERATURE

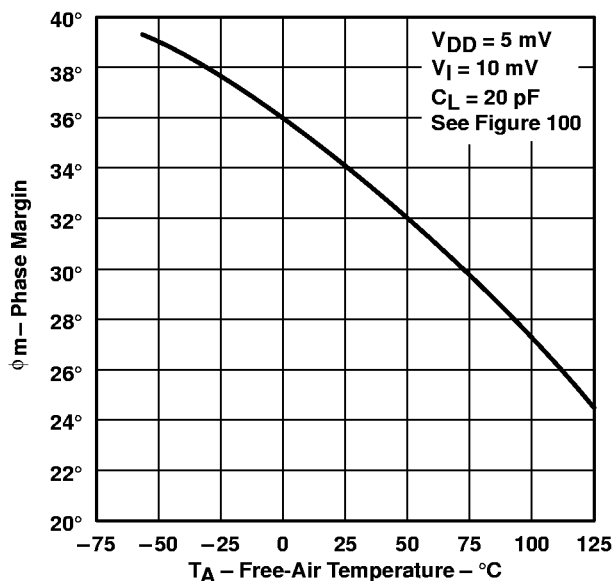

Figure 95

† Data at high and low temperatures are applicable only within the rated operating free-air temperature ranges of the various devices.

TYPICAL CHARACTERISTICS (LOW-BIAS MODE)†

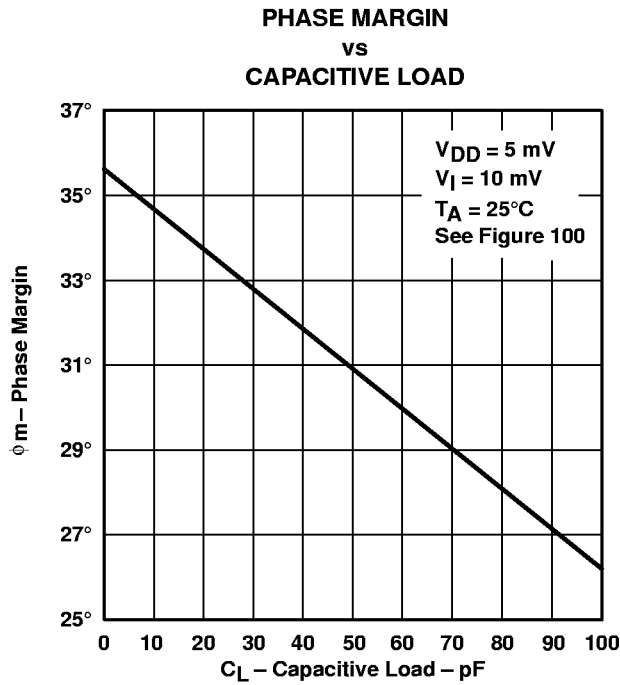

Figure 96

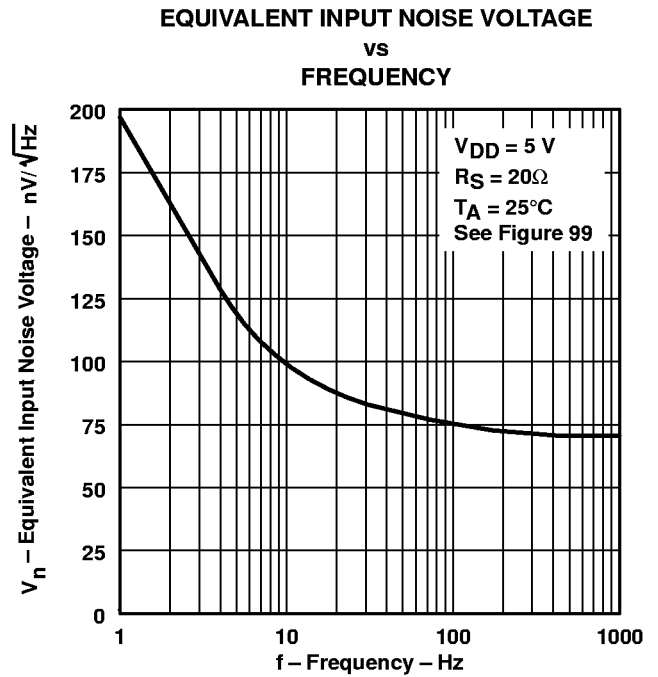

Figure 97

† Data at high and low temperatures are applicable only within the rated operating free-air temperature ranges of the various devices.

PARAMETER MEASUREMENT INFORMATION

single-supply versus split-supply test circuits

Because the TLC271 is optimized for single-supply operation, circuit configurations used for the various tests often present some inconvenience since the input signal, in many cases, must be offset from ground. This inconvenience can be avoided by testing the device with split supplies and the output load tied to the negative rail. A comparison of single-supply versus split-supply test circuits is shown below. The use of either circuit gives the same result.

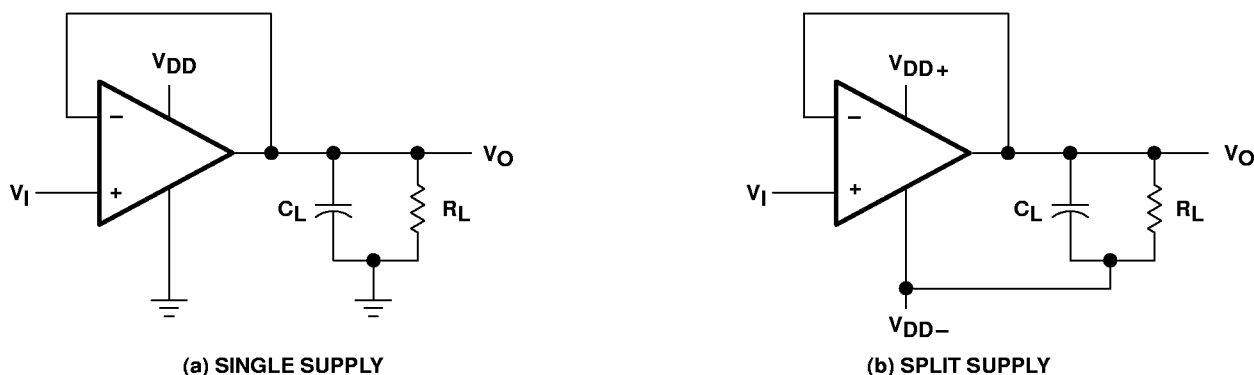

Figure 98. Unity-Gain Amplifier

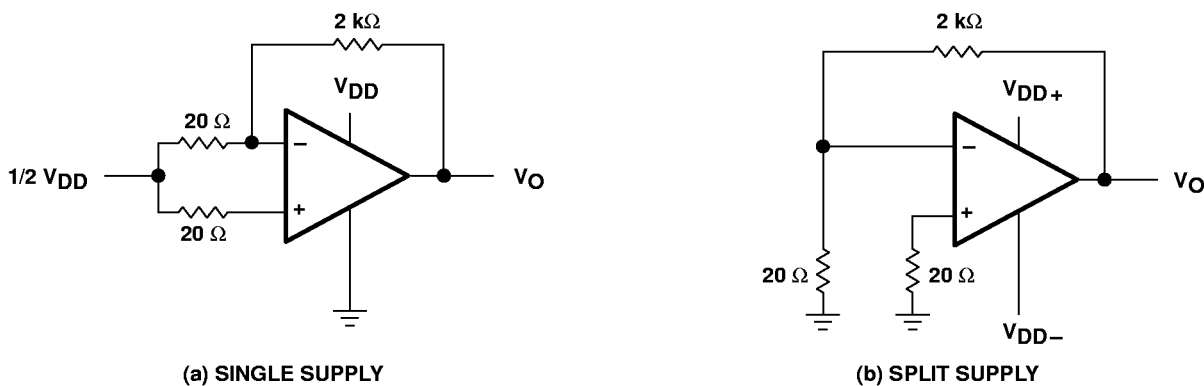

Figure 99. Noise-Test Circuit

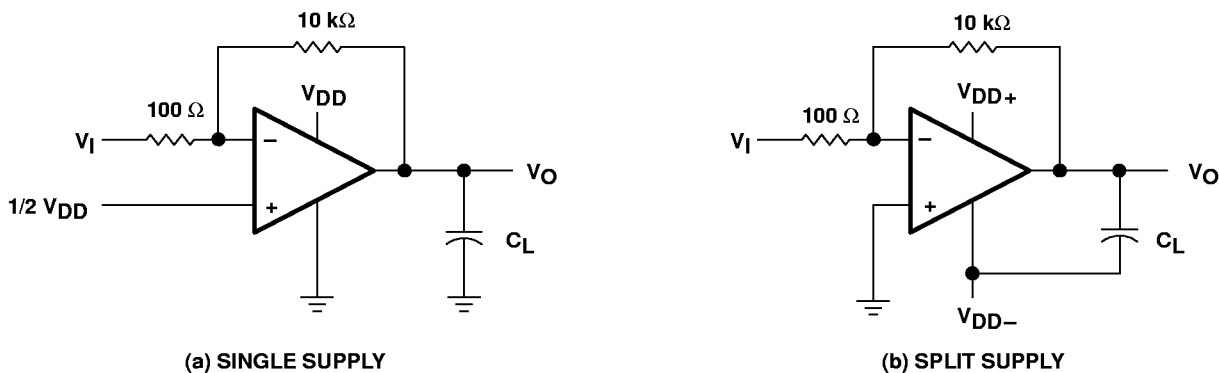

Figure 100. Gain-of-100 Inverting Amplifier

PARAMETER MEASUREMENT INFORMATION

input bias current

Because of the high input impedance of the TLC271 operational amplifiers, attempts to measure the input bias current can result in erroneous readings. The bias current at normal room ambient temperature is typically less than 1 pA, a value that is easily exceeded by leakages on the test socket. Two suggestions are offered to avoid erroneous measurements:

1. Isolate the device from other potential leakage sources. Use a grounded shield around and between the device inputs (see Figure 101). Leakages that would otherwise flow to the inputs are shunted away.
2. Compensate for the leakage of the test socket by actually performing an input bias current test (using a picoammeter) with no device in the test socket. The actual input bias current can then be calculated by subtracting the open-socket leakage readings from the readings obtained with a device in the test socket.

One word of caution: many automatic testers as well as some bench-top operational amplifier testers use the servo-loop technique with a resistor in series with the device input to measure the input bias current (the voltage drop across the series resistor is measured and the bias current is calculated). This method requires that a device be inserted into the test socket to obtain a correct reading; therefore, an open-socket reading is not feasible using this method.

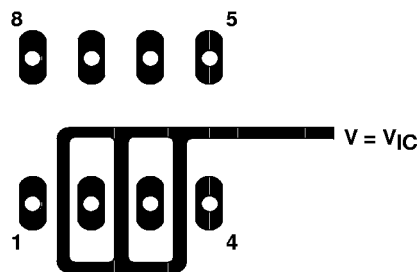

Figure 101. Isolation Metal Around Device inputs (JG and P packages)

low-level output voltage

To obtain low-supply-voltage operation, some compromise is necessary in the input stage. This compromise results in the device low-level output being dependent on both the common-mode input voltage level as well as the differential input voltage level. When attempting to correlate low-level output readings with those quoted in the electrical specifications, these two conditions should be observed. If conditions other than these are to be used, please refer to the Typical Characteristics section of this data sheet.

input offset voltage temperature coefficient

Erroneous readings often result from attempts to measure temperature coefficient of input offset voltage. This parameter is actually a calculation using input offset voltage measurements obtained at two different temperatures. When one (or both) of the temperatures is below freezing, moisture can collect on both the device and the test socket. This moisture results in leakage and contact resistance which can cause erroneous input offset voltage readings. The isolation techniques previously mentioned have no effect on the leakage since the moisture also covers the isolation metal itself, thereby rendering it useless. It is suggested that these measurements be performed at temperatures above freezing to minimize error.

PARAMETER MEASUREMENT INFORMATION

full-power response

Full-power response, the frequency above which the amplifier slew rate limits the output voltage swing, is often specified two ways: full-linear response and full-peak response. The full-linear response is generally measured by monitoring the distortion level of the output while increasing the frequency of a sinusoidal input signal until the maximum frequency is found above which the output contains significant distortion. The full-peak response is defined as the maximum output frequency, without regard to distortion, above which full peak-to-peak output swing cannot be maintained.

Because there is no industry-wide accepted value for significant distortion, the full-peak response is specified in this data sheet and is measured using the circuit of Figure 98. The initial setup involves the use of a sinusoidal input to determine the maximum peak-to-peak output of the device (the amplitude of the sinusoidal wave is increased until clipping occurs). The sinusoidal wave is then replaced with a square wave of the same amplitude. The frequency is then increased until the maximum peak-to-peak output can no longer be maintained (Figure 102). A square wave is used to allow a more accurate determination of the point at which the maximum peak-to-peak output is reached.

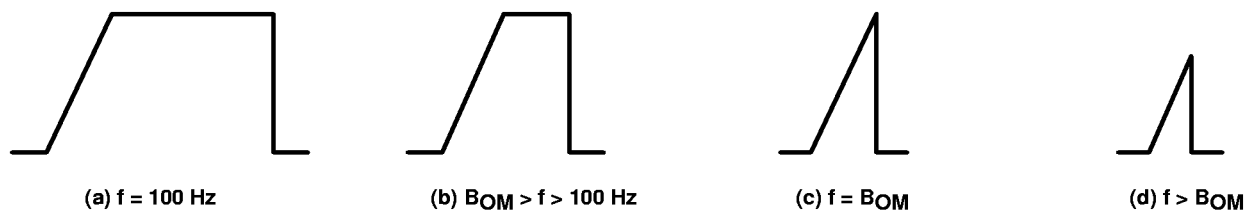

Figure 102. Full-Power-Response Output Signal

test time

Inadequate test time is a frequent problem, especially when testing CMOS devices in a high-volume, short-test-time environment. Internal capacitances are inherently higher in CMOS than in bipolar and BIFET devices, and require longer test times than their bipolar and BiFET counterparts. The problem becomes more pronounced with reduced supply levels and lower temperatures.

APPLICATION INFORMATION

single-supply operation

While the TLC271 performs well using dual power supplies (also called balanced or split supplies), the design is optimized for single-supply operation. This includes an input common mode voltage range that encompasses ground as well as an output voltage range that pulls down to ground. The supply voltage range extends down to 3 V (C-suffix types), thus allowing operation with supply levels commonly available for TTL and HCMOS; however, for maximum dynamic range, 16-V single-supply operation is recommended.

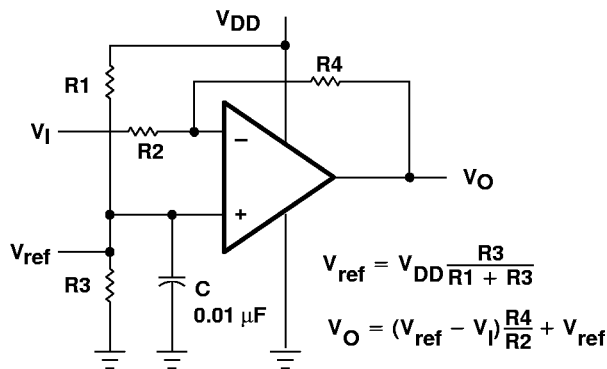

Figure 103. Inverting Amplifier With Voltage Reference

APPLICATION INFORMATION

single-supply operation (continued)

Many single-supply applications require that a voltage be applied to one input to establish a reference level that is above ground. A resistive voltage divider is usually sufficient to establish this reference level (see Figure 103). The low input bias current consumption of the TLC271 permits the use of very large resistive values to implement the voltage divider, thus minimizing power consumption.

The TLC271 works well in conjunction with digital logic; however, when powering both linear devices and digital logic from the same power supply, the following precautions are recommended:

1. Power the linear devices from separate bypassed supply lines (see Figure 104); otherwise, the linear device supply rails can fluctuate due to voltage drops caused by high switching currents in the digital logic.
2. Use proper bypass techniques to reduce the probability of noise-induced errors. Single capacitive decoupling is often adequate; however, RC decoupling may be necessary in high-frequency applications.

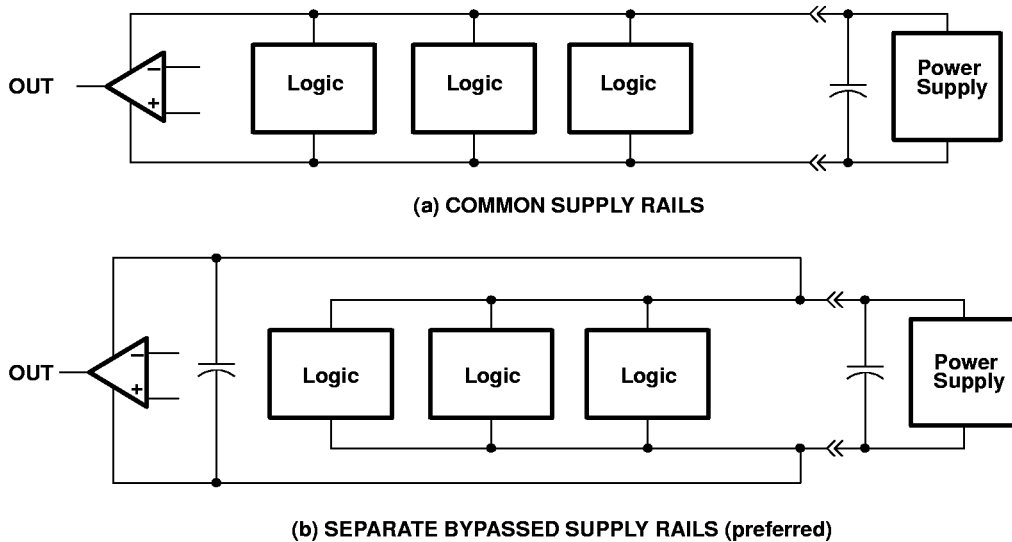

Figure 104. Common Versus Separate Supply Rails

APPLICATION INFORMATION

input offset voltage nulling

The TLC271 offers external input offset null control. Nulling of the input off set voltage may be achieved by adjusting a 25-kΩ potentiometer connected between the offset null terminals with the wiper Connected as shown in Figure 105. The amount of nulling range varies with the bias selection. In the high-bias mode, the nulling range allows the maximum offset voltage specified to be trimmed to zero. In low-bias and medium-bias modes, total nulling may not be possible.

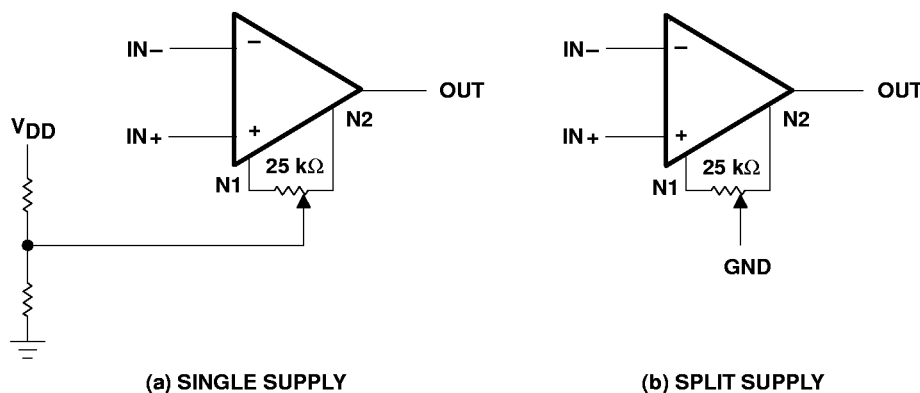

Figure 105. Input Offset Voltage Null Circuit

bias selection

Bias selection is achieved by connecting the bias select pin to one of the three voltage levels (see Figure 106). For medium-bias applications, R is recommended that the bias select pin be connected to the mid-point between the supply rails. This is a simple procedure in split-supply applications, since this point is ground. In single-supply applications, the medium-bias mode necessitates using a voltage divider as indicated. The use of large-value resistors in the voltage divider reduces the current drain of the divider from the supply line. However, large-value resistors used in conjunction with a large-value capacitor requires significant time to charge up to the supply midpoint after the supply is switched on. A voltage other than the midpoint may be used if it is within the voltages specified in the table of Figure 106.

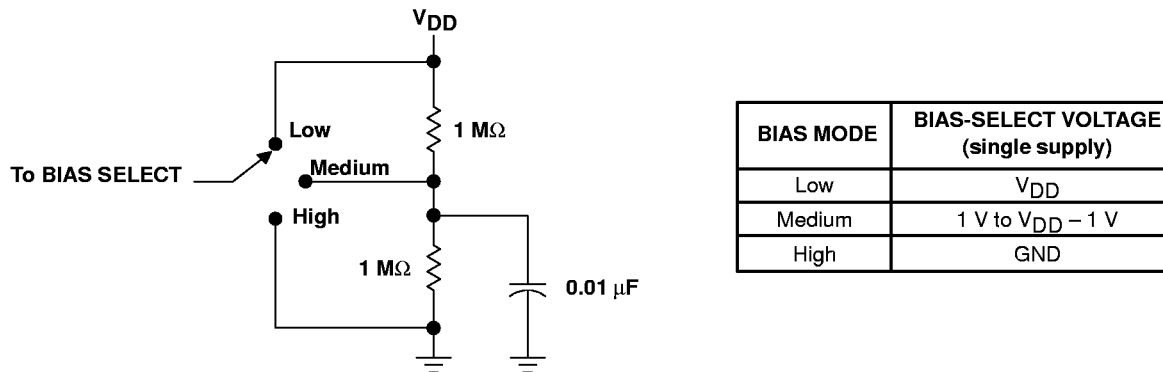

Figure 106. Bias Selection for Single-Supply Applications

APPLICATION INFORMATION

input characteristics

The TLC271 is specified with a minimum and a maximum input voltage that, if exceeded at either input, could cause the device to malfunction. Exceeding this specified range is a common problem, especially in single-supply operation. Note that the lower range limit includes the negative rail, while the upper range limit is specified at $V_{DD} - 1\text{ V}$ at $T_A = 25^\circ\text{C}$ and at $V_{DD} - 1.5\text{ V}$ at all other temperatures.

The use of the polysilicon-gate process and the careful input circuit design gives the TLC271 very good input offset voltage drift characteristics relative to conventional metal-gate processes. Offset voltage drift in CMOS devices is highly influenced by threshold voltage shifts caused by polarization of the phosphorus dopant implanted in the oxide. Placing the phosphorus dopant in a conductor (such as a polysilicon gate) alleviates the polarization problem, thus reducing threshold voltage shifts by more than an order of magnitude. The offset voltage drift with time has been calculated to be typically $0.1\ \mu\text{V}/\text{month}$, including the first month of operation.

Because of the extremely high input impedance and resulting low bias current requirements, the TLC271 is well suited for low-level signal processing; however, leakage currents on printed circuit boards and sockets can easily exceed bias current requirements and cause a degradation in device performance. It is good practice to include guard rings around inputs (similar to those of Figure 101 in the Parameter Measurement Information section). These guards should be driven from a low-impedance source at the same voltage level as the common-mode input (see Figure 107).

The inputs of any unused amplifiers should be tied to ground to avoid possible oscillation.

noise performance

The noise specifications in operational amplifier circuits are greatly dependent on the current in the first-stage differential amplifier. The low input bias current requirements of the TLC271 results in a very low noise current, which is insignificant in most applications. This feature makes the devices especially favorable over bipolar devices when using values of circuit impedance greater than $50\ \text{k}\Omega$, since bipolar devices exhibit greater noise currents.

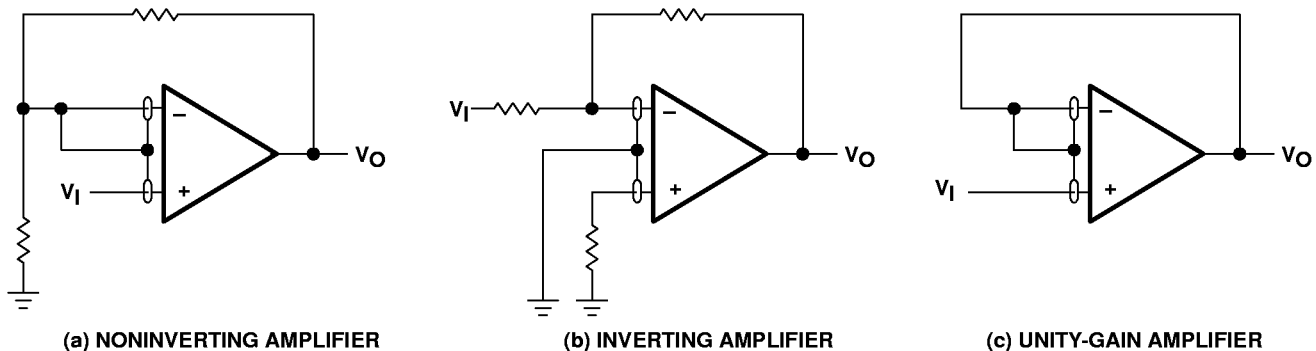

Figure 107. Guard-Ring Schemes

APPLICATION INFORMATION

feedback

Operational amplifier circuits almost always employ feedback, and since feedback is the first prerequisite for oscillation, a little caution is appropriate. Most oscillation problems result from driving capacitive loads and ignoring stray input capacitance. A small-value capacitor connected in parallel with the feedback resistor is an effective remedy (see Figure 108). The value of this capacitor is optimized empirically.

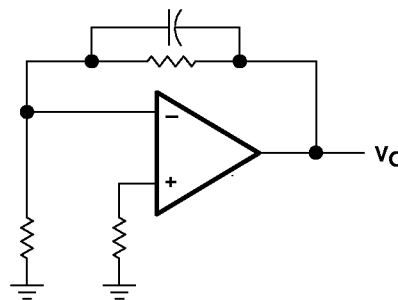

Figure 108. Compensation for Input Capacitance

electrostatic discharge protection

The TLC271 incorporates an internal electrostatic-discharge (ESD) protection circuit that prevents functional failures at voltages up to 2000 V as tested under MIL-STD-883C, Method 3015.2. Care should be exercised, however, when handling these devices as exposure to ESD may result in the degradation of the device parametric performance. The protection circuit also causes the input bias currents to be temperature dependent and have the characteristics of a reverse-biased diode.

latch-up

Because CMOS devices are susceptible to latch-up due to their inherent parasitic thyristors, the TLC271 inputs and output were designed to withstand –100-mA surge currents without sustaining latchup; however, techniques should be used to reduce the chance of latch-up whenever possible. Internal protection diodes should not by design be forward biased. Applied input and output voltage should not exceed the supply voltage by more than 300 mV. Care should be exercised when using capacitive coupling on pulse generators. Supply transients should be shunted by the use of decoupling capacitors (0.1 μF typical) located across the supply rails as close to the device as possible.

The current path established if latch-up occurs is usually between the positive supply rail and ground and can be triggered by surges on the supply lines and/or voltages on either the output or inputs that exceed the supply voltage. Once latch-up occurs, the current flow is limited only by the impedance of the power supply and the forward resistance of the parasitic thyristor and usually results in the destruction of the device. The chance of latch-up occurring increases with increasing temperature and supply voltages.

output characteristics

The output stage of the TLC271 is designed to sink and source relatively high amounts of current (see Typical Characteristics). If the output is subjected to a short-circuit condition, this high current capability can cause device damage under certain conditions. Output current capability increases with supply voltage.

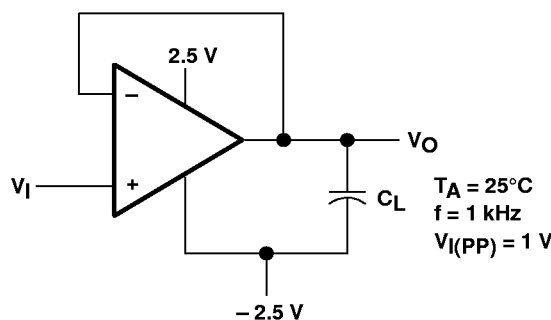

Figure 109. Test Circuit for Output Characteristics

APPLICATION INFORMATION

output characteristics (continued)

All operating characteristics of the TLC271 were measured using a 20-pF load. The devices drive higher capacitive loads; however, as output load capacitance increases, the resulting response pole occurs at lower frequencies, thereby causing ringing, peaking, or even oscillation (see Figures 110, 111, and 112). In many cases, adding some compensation in the form of a series resistor in the feedback loop alleviates the problem.

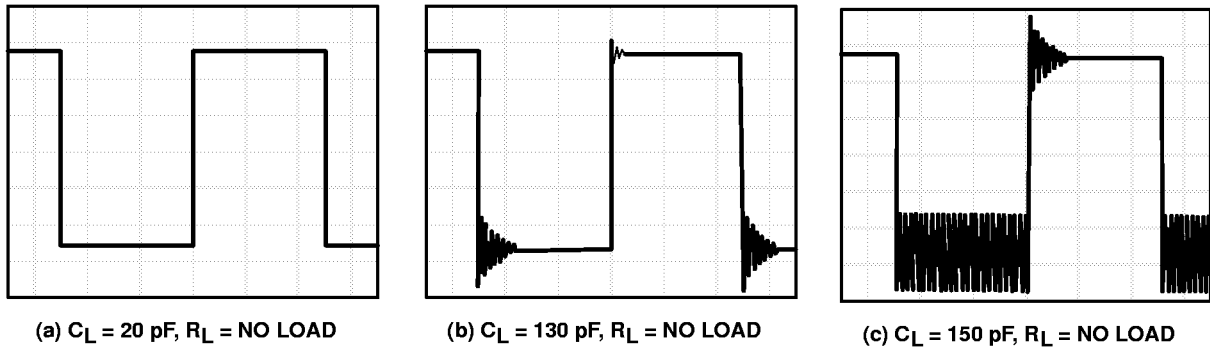

Figure 110. Effect of Capacitive Loads in High-Bias Mode

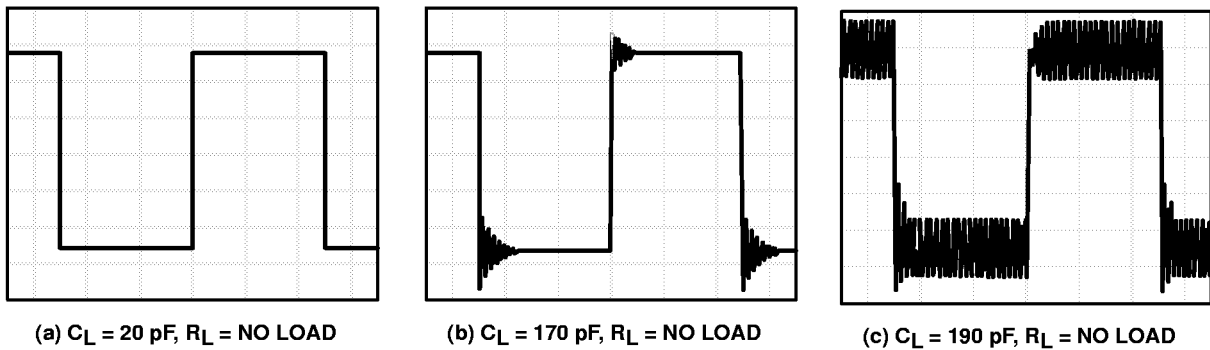

Figure 111. Effect of Capacitive Loads in Medium-Bias Mode

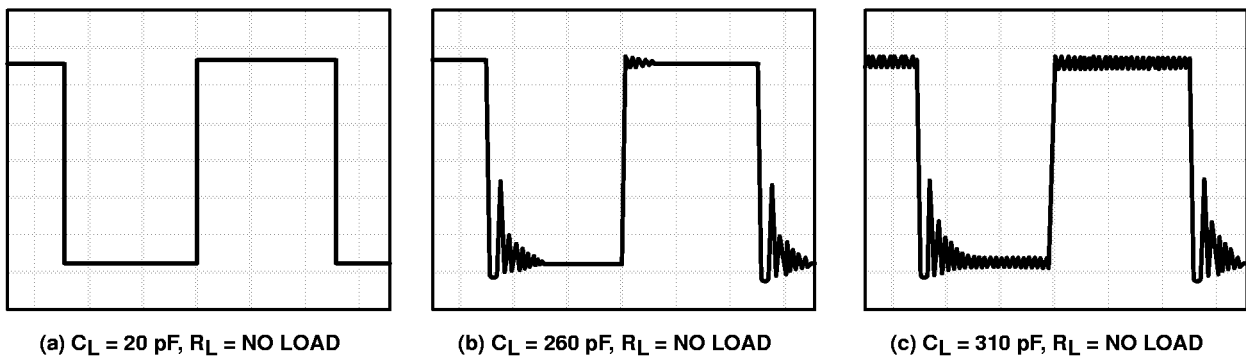

Figure 112. Effect of Capacitive Loads in Low-Bias Mode

APPLICATION INFORMATION

output characteristics (continued)

Although the TLC271 possesses excellent high-level output voltage and current capability, methods are available for boosting this capability, if needed. The simplest method involves the use of a pullup resistor (R_P) connected from the output to the positive supply rail (see Figure 113). There are two disadvantages to the use of this circuit. First, the NMOS pulldown transistor, N4 (see equivalent schematic) must sink a comparatively large amount of current. In this circuit, N4 behaves like a linear resistor with an on-resistance between approximately 60Ω and 180Ω , depending on how hard the operational amplifier input is driven. With very low values of R_P , a voltage offset from 0 V at the output occurs. Secondly, pullup resistor R_P acts as a drain load to N4 and the gain of the operational amplifier is reduced at output voltage levels where N5 is not supplying the output current.

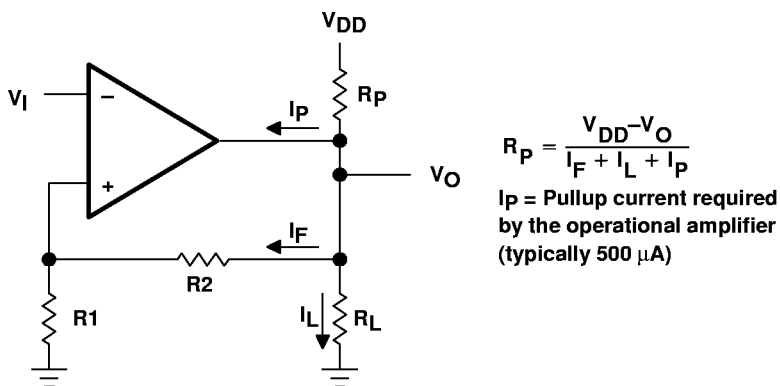
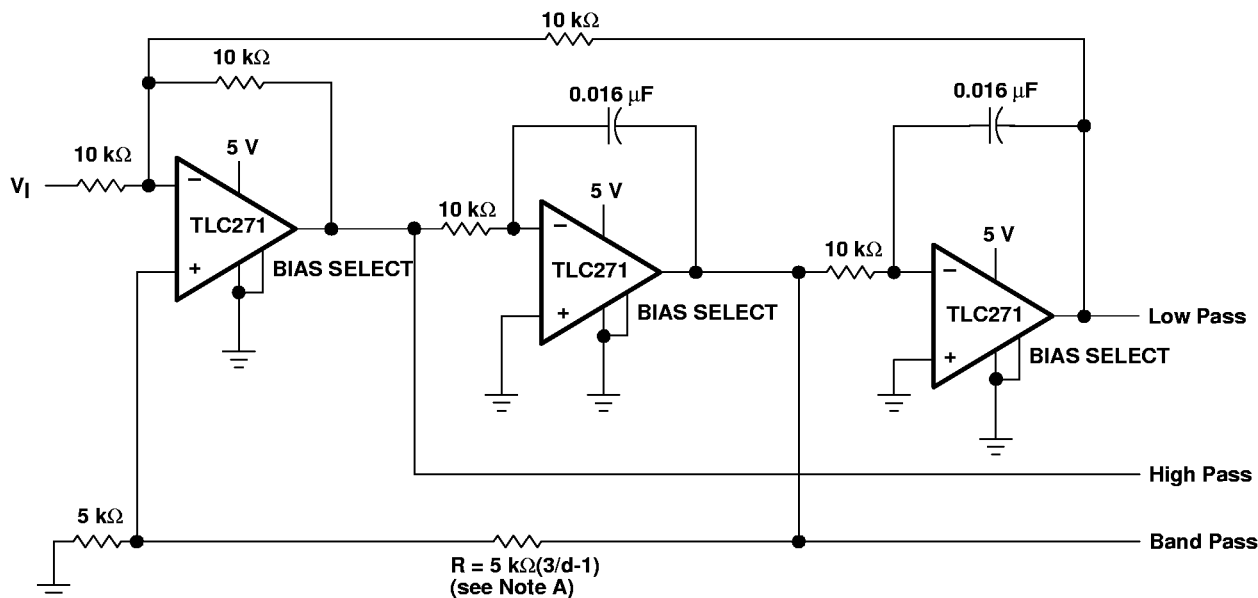

Figure 113. Resistive Pullup to Increase V_{OH}



NOTE B: d = damping factor, I/O

Figure 114. State-Variable Filter

APPLICATION INFORMATION

output characteristics (continued)

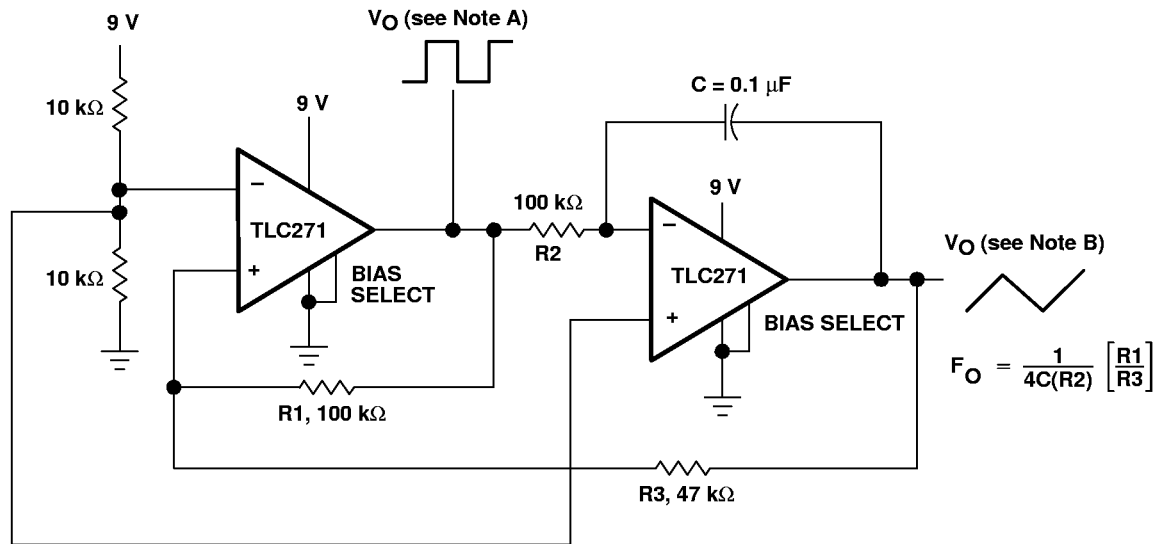

$$F_O = \frac{1}{4C(R2)} \left[\frac{R1}{R3} \right]$$

- NOTES: A. V_{O(PP)} = 8 V
 B. V_{O(PP)} = 4 V

Figure 115. Single-Supply Function Generator

APPLICATION INFORMATION (HIGH-BIAS MODE)

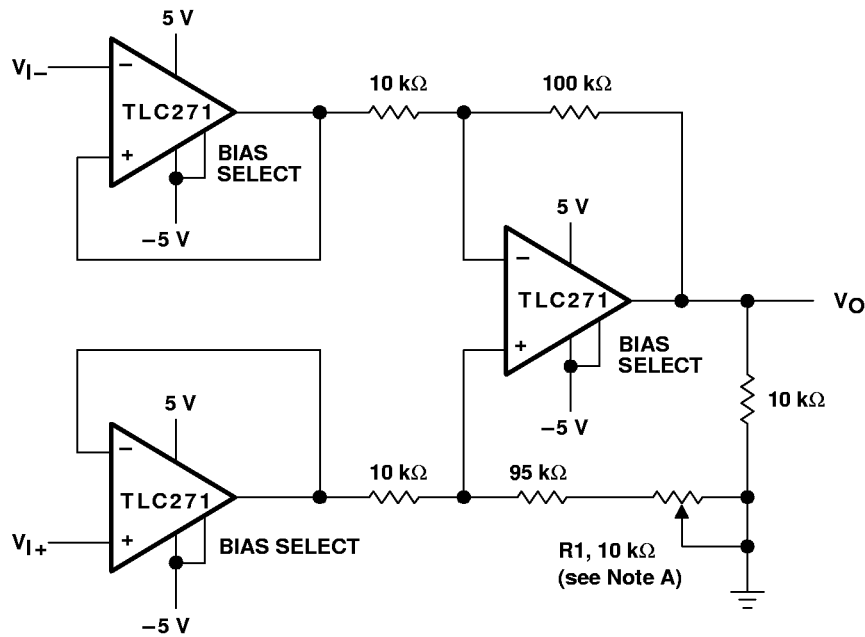

NOTE A: CMRR adjustment must be noninductive.

Figure 116. Low-Power Instrumentation Amplifier

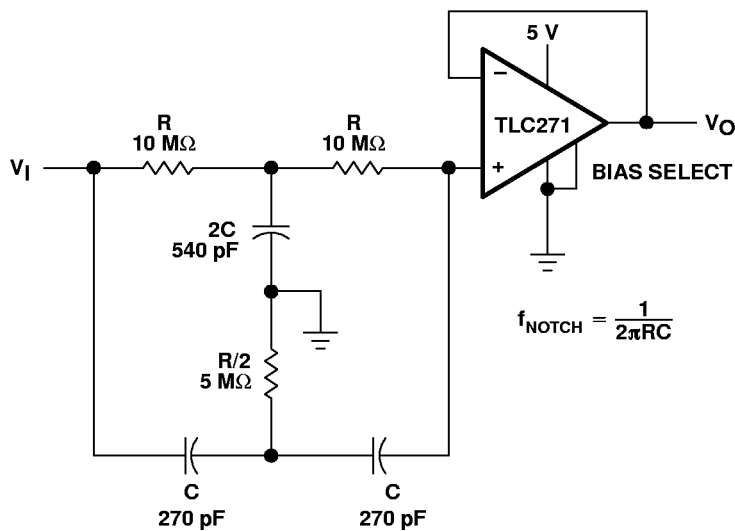

$$f_{\text{NOTCH}} = \frac{1}{2\pi RC}$$

Figure 117. Single-Supply Twin-T Notch Filter

APPLICATION INFORMATION (HIGH-BIAS MODE)

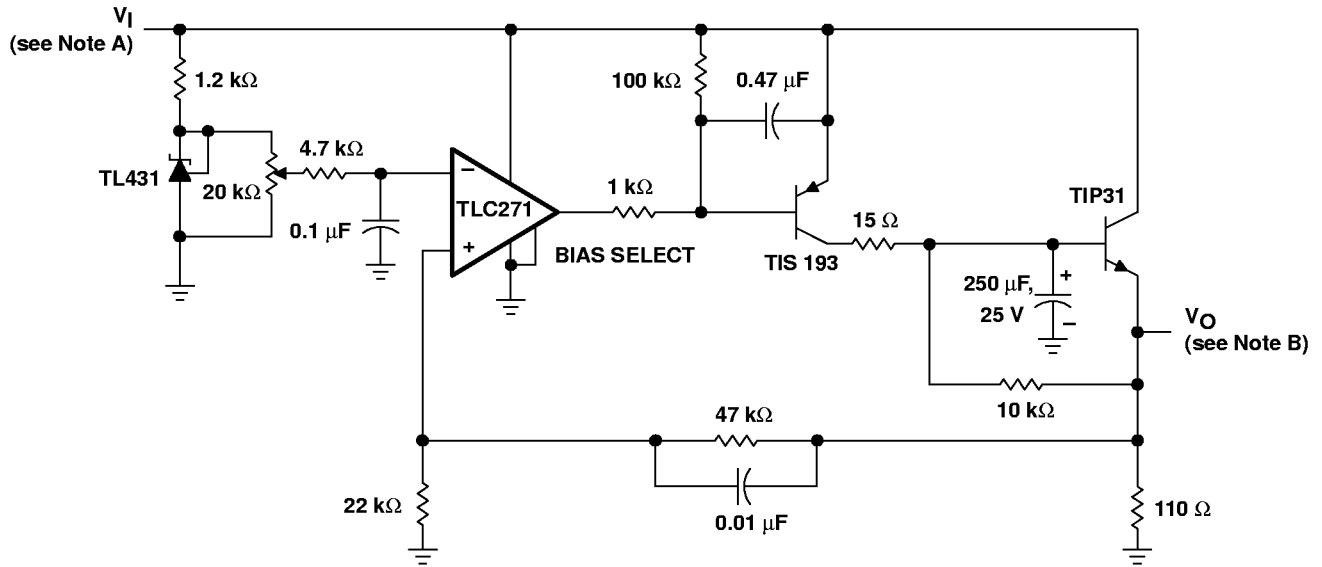

NOTES: A. $V_I = 3.5$ to 15 V
 B. $V_O = 2.0$ V, 0 to 1 A

Figure 118. Logic-Array Power Supply

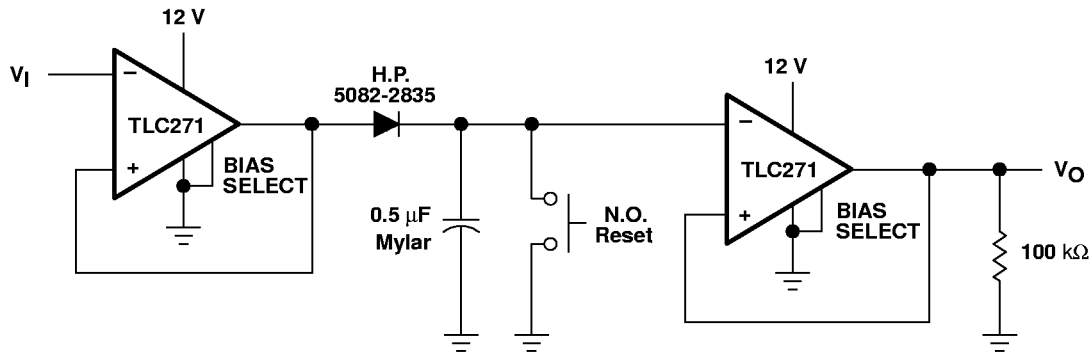
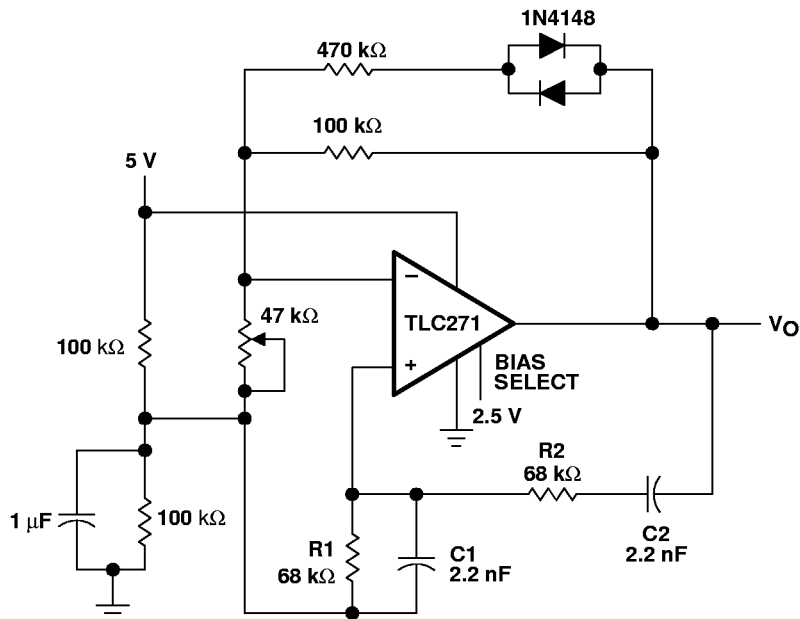

Figure 119. Positive-Peak Detector

APPLICATION INFORMATION (MEDIUM-BIAS MODE)



NOTES: A. $V_{O(PP)} = 2\text{ V}$

B. $f_o = \frac{1}{2\pi \sqrt{R_1 R_2 C_1 C_2}}$

Figure 120. Wein Oscillator

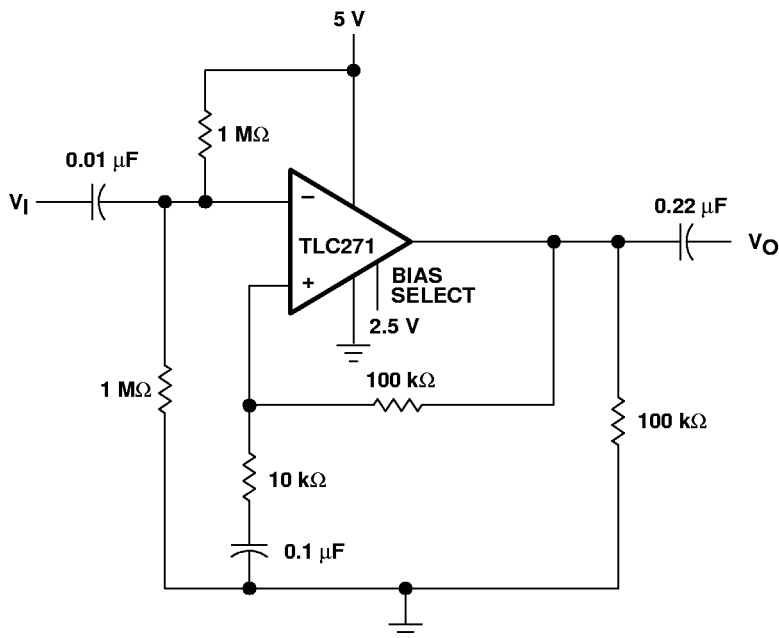
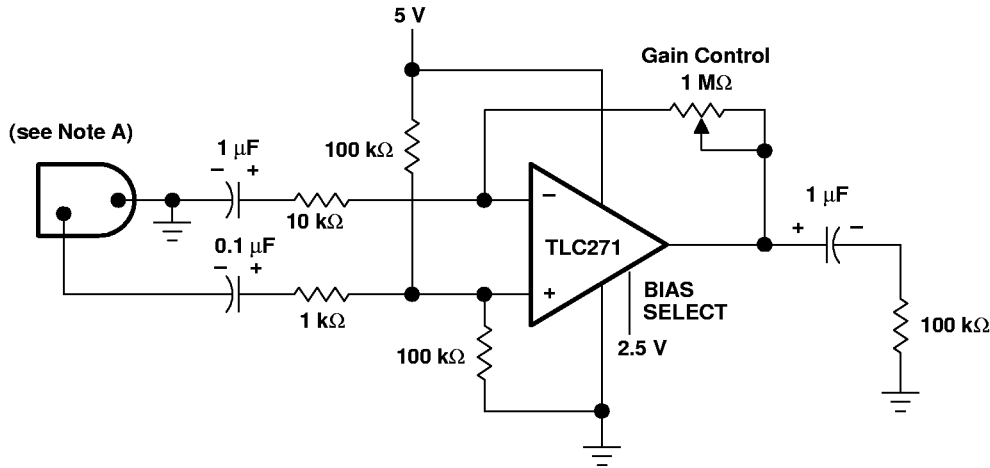

Figure 121. Single-Supply AC Amplifier

APPLICATION INFORMATION (MEDIUM-BIAS MODE)



NOTE A: Low to medium impedance dynamic mike

Figure 122. Microphone Preamplifier

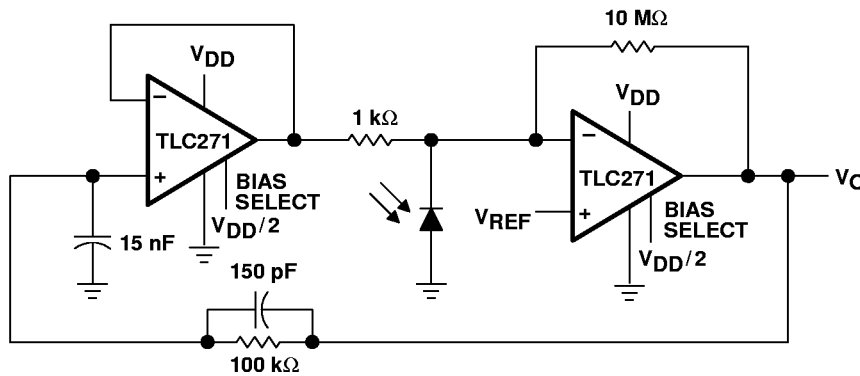

NOTES: A. $V_{DD} = 4 \text{ V to } 15 \text{ V}$
 B. $V_{ref} = 0 \text{ V to } V_{DD} - 2 \text{ V}$

Figure 123. Photo-Diode Amplifier With Ambient Light Rejection

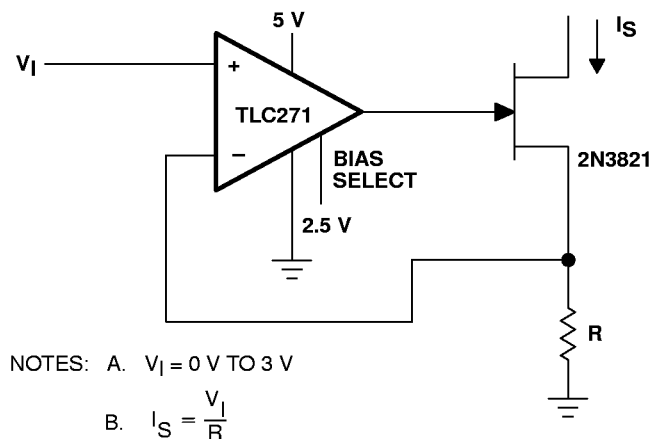

NOTES: A. $V_I = 0 \text{ V TO } 3 \text{ V}$
 B. $I_S = \frac{V_I}{R}$

Figure 124. Precision Low-Current Sink

APPLICATION INFORMATION (LOW-BIAS MODE)

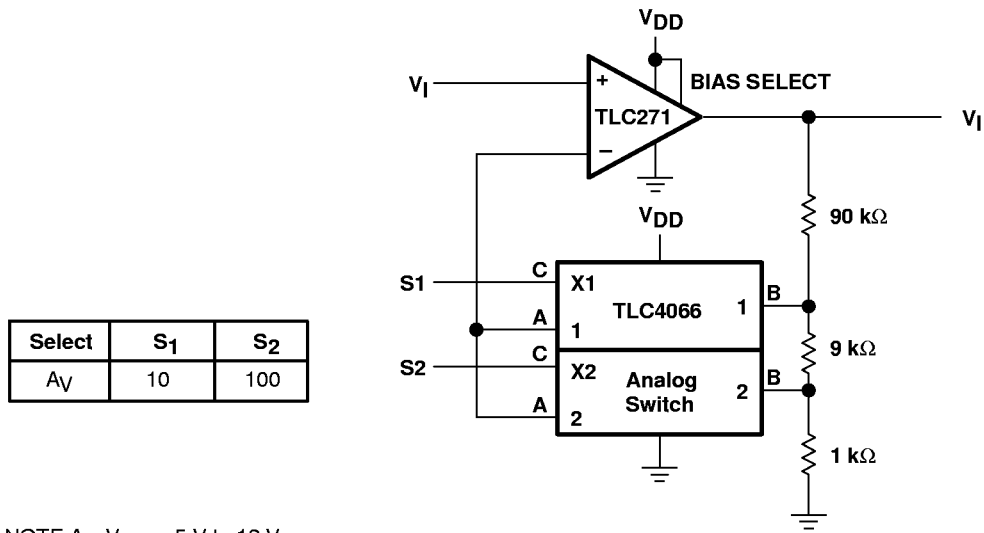

NOTE A: V_{DD} = 5 V to 12 V

Figure 125. Amplifier With Digital Gain Selection

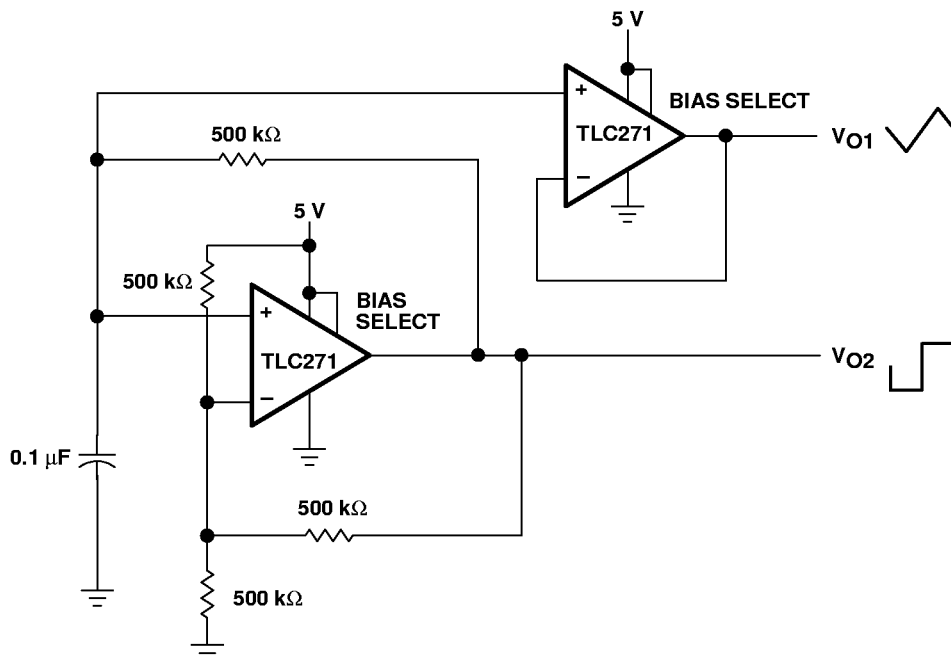
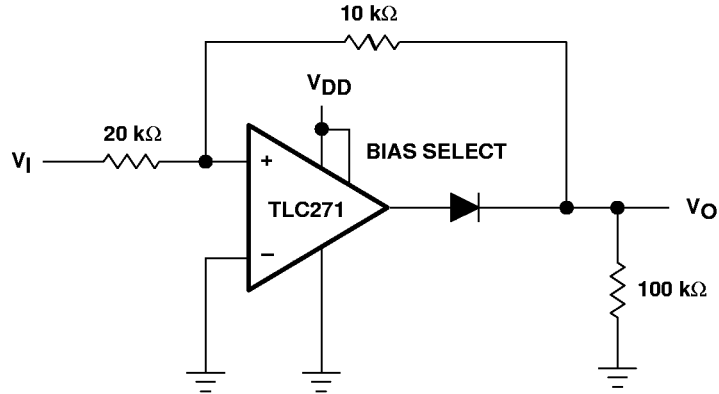

Figure 126. Multivibrator

APPLICATION INFORMATION (LOW-BIAS MODE)



NOTE A: $V_{DD} = 5\text{ V to }16\text{ V}$

Figure 127. Full-Wave Rectifier

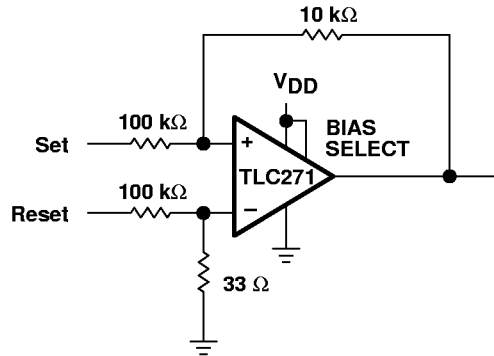

NOTE A: $V_{DD} = 5\text{ V to }16\text{ V}$

Figure 128. Set/Reset Flip-Flop

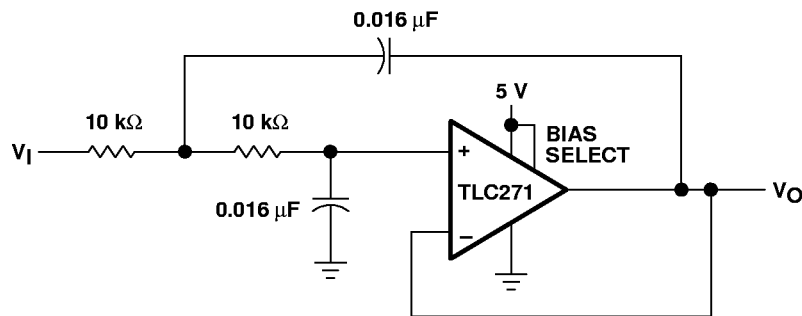

NOTE A: Normalized to $F_C = 1\text{ kHz}$ and $R_L = 10\text{ k}\Omega$

Figure 129. Two-Pole Low-Pass Butterworth Filter

TLC271, TLC271A, TLC271B
LinCMOS™ PROGRAMMABLE LOW-POWER
OPERATIONAL AMPLIFIERS

SLOS090C – NOVEMBER 1987 – REVISED AUGUST 1997

MECHANICAL INFORMATION

D (R-PDSO-G)**

PLASTIC SMALL-OUTLINE PACKAGE

14 PIN SHOWN

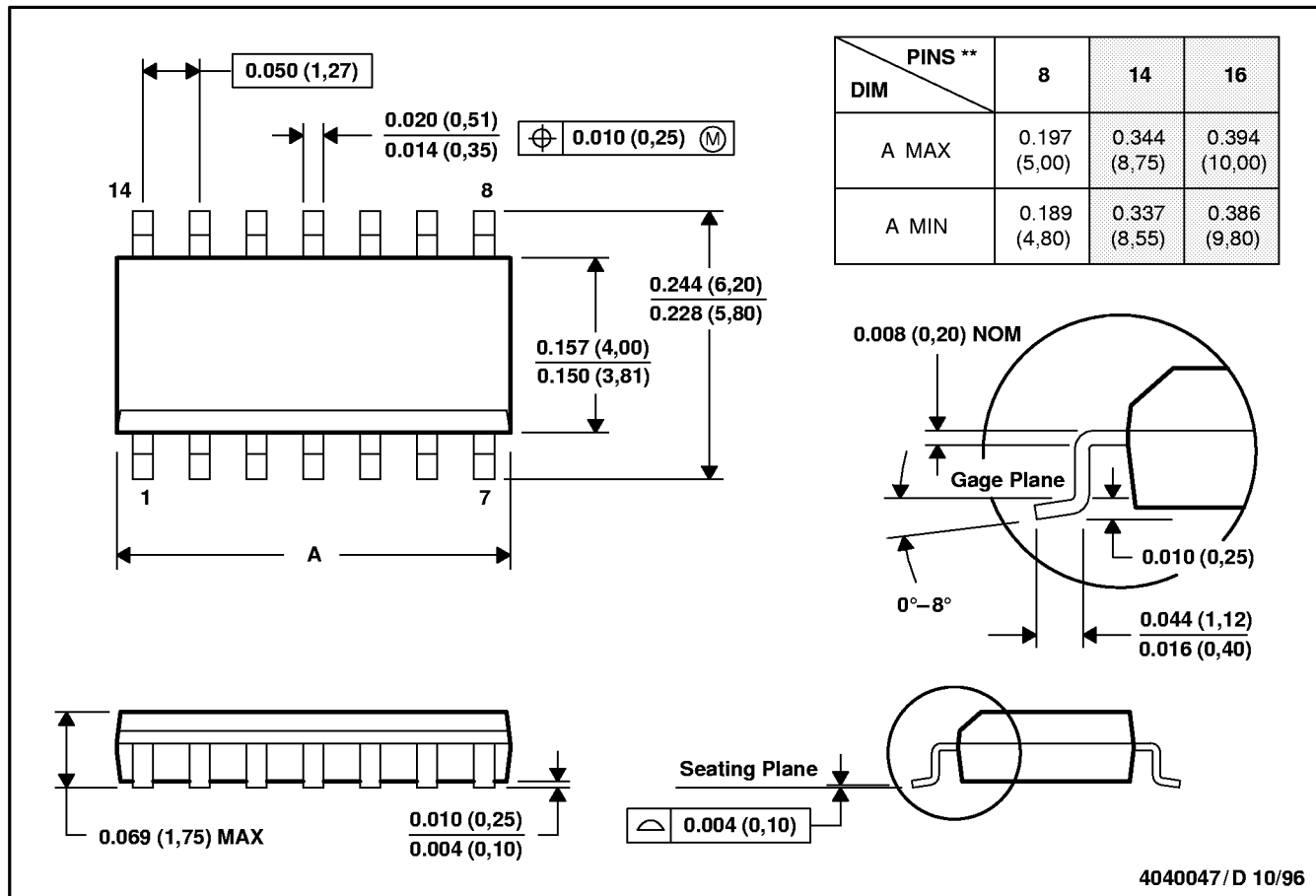

- NOTES: A. All linear dimensions are in inches (millimeters).
 B. This drawing is subject to change without notice.
 C. Body dimensions do not include mold flash or protrusion, not to exceed 0.006 (0,15).
 D. Falls within JEDEC MS-012

MECHANICAL INFORMATION

FK (S-CQCC-N)**

LEADLESS CERAMIC CHIP CARRIER

28 TERMINAL SHOWN

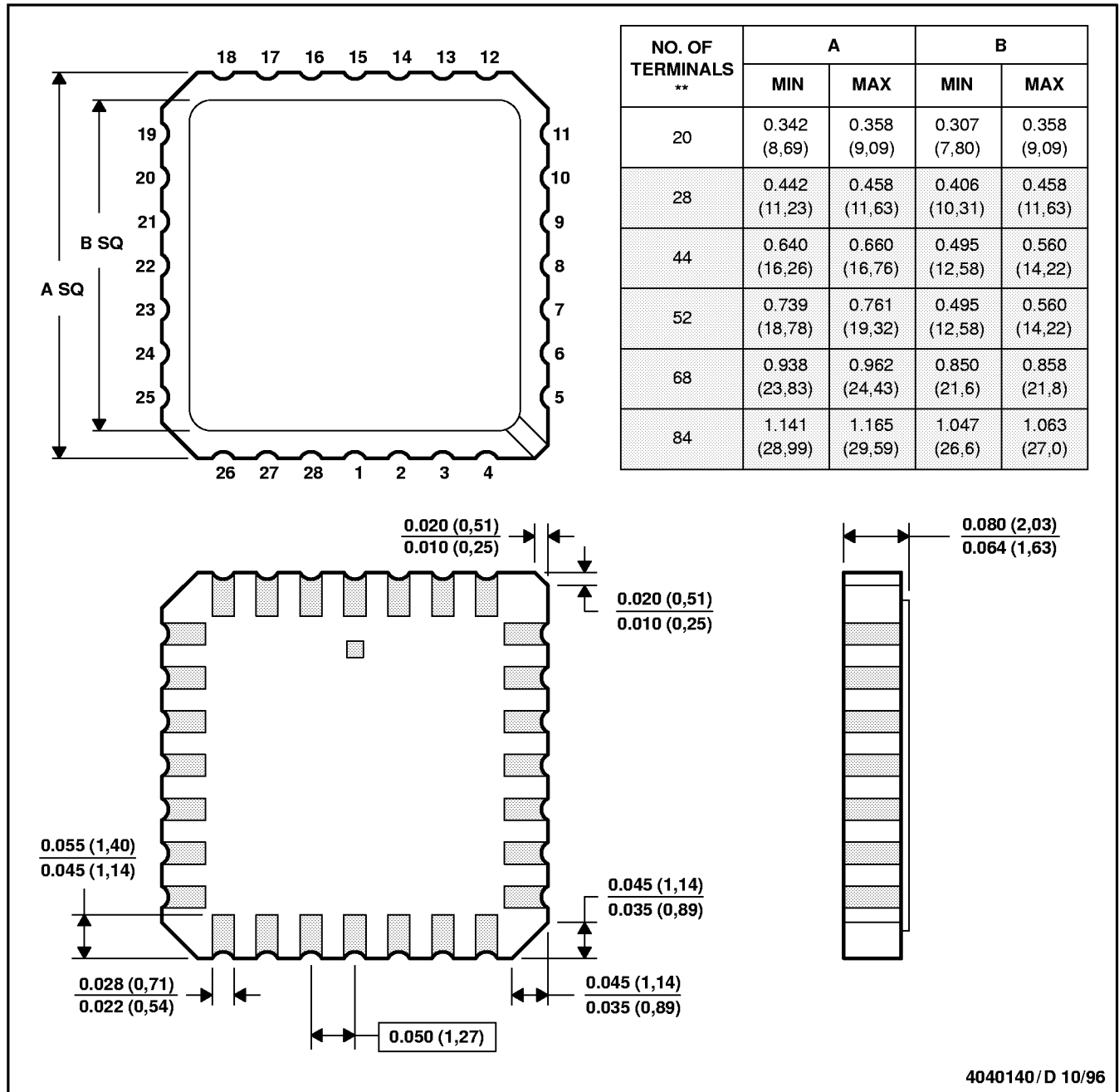

- NOTES: A. All linear dimensions are in inches (millimeters).
 B. This drawing is subject to change without notice.
 C. This package can be hermetically sealed with a metal lid.
 D. The terminals are gold plated.
 E. Falls within JEDEC MS-004

TLC271, TLC271A, TLC271B
**LinCMOS™ PROGRAMMABLE LOW-POWER
 OPERATIONAL AMPLIFIERS**

SLOS090C – NOVEMBER 1987 – REVISED AUGUST 1997

MECHANICAL INFORMATION

JG (R-GDIP-T8)

CERAMIC DUAL-IN-LINE PACKAGE

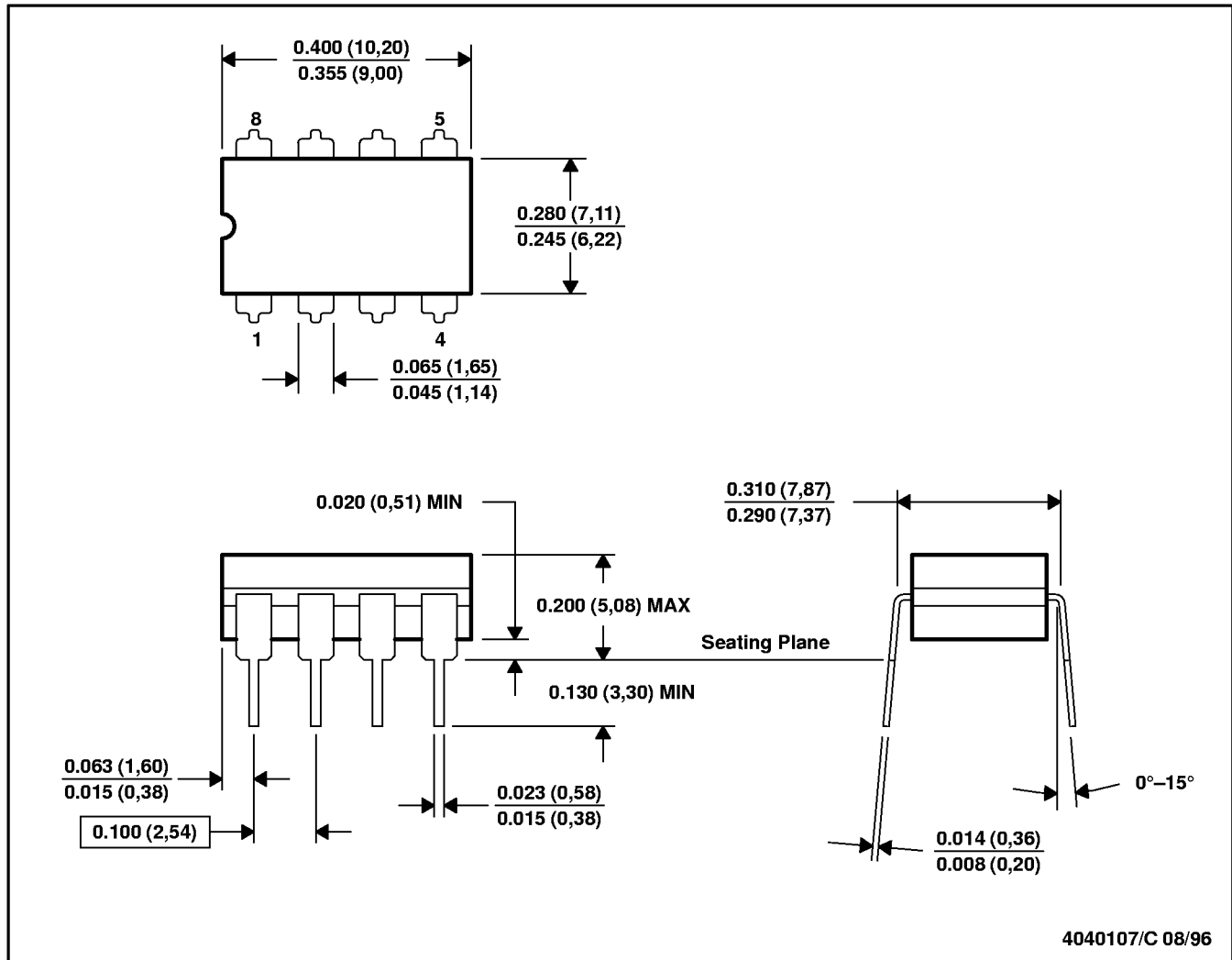

- NOTES: A. All linear dimensions are in inches (millimeters).
 B. This drawing is subject to change without notice.
 C. This package can be hermetically sealed with a ceramic lid using glass frit.
 D. Index point is provided on cap for terminal identification only on press ceramic glass frit seal only.
 E. Falls within MIL-STD-1835 GDIP1-T8

MECHANICAL INFORMATION

P (R-PDIP-T8)

PLASTIC DUAL-IN-LINE PACKAGE

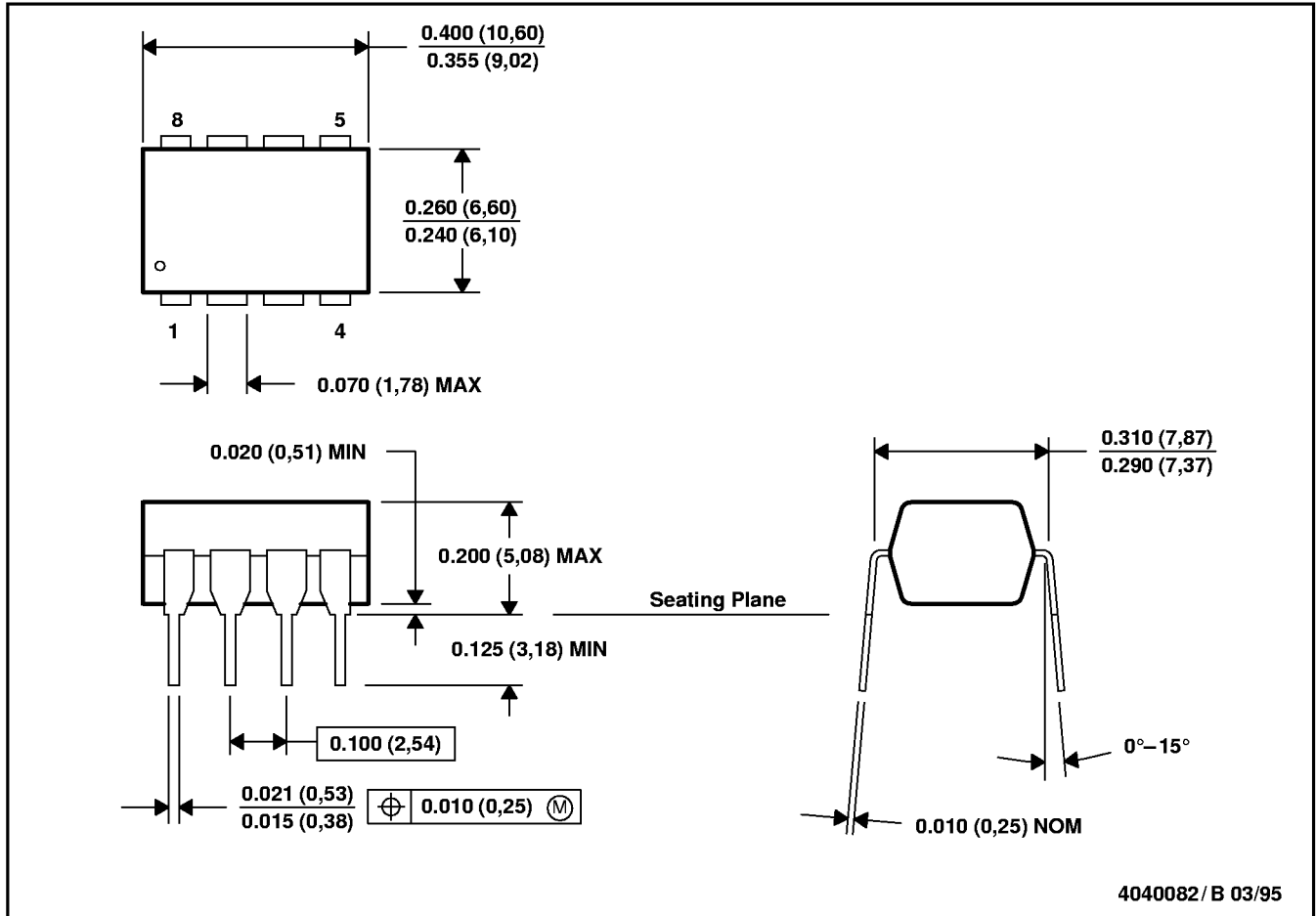

- NOTES: A. All linear dimensions are in inches (millimeters).
 B. This drawing is subject to change without notice.
 C. Falls within JEDEC MS-001

IMPORTANT NOTICE

Texas Instruments (TI) reserves the right to make changes to its products or to discontinue any semiconductor product or service without notice, and advises its customers to obtain the latest version of relevant information to verify, before placing orders, that the information being relied on is current.

TI warrants performance of its semiconductor products and related software to the specifications applicable at the time of sale in accordance with TI's standard warranty. Testing and other quality control techniques are utilized to the extent TI deems necessary to support this warranty. Specific testing of all parameters of each device is not necessarily performed, except those mandated by government requirements.

Certain applications using semiconductor products may involve potential risks of death, personal injury, or severe property or environmental damage ("Critical Applications").

TI SEMICONDUCTOR PRODUCTS ARE NOT DESIGNED, INTENDED, AUTHORIZED, OR WARRANTED TO BE SUITABLE FOR USE IN LIFE-SUPPORT APPLICATIONS, DEVICES OR SYSTEMS OR OTHER CRITICAL APPLICATIONS.

Inclusion of TI products in such applications is understood to be fully at the risk of the customer. Use of TI products in such applications requires the written approval of an appropriate TI officer. Questions concerning potential risk applications should be directed to TI through a local SC sales office.

In order to minimize risks associated with the customer's applications, adequate design and operating safeguards should be provided by the customer to minimize inherent or procedural hazards.

TI assumes no liability for applications assistance, customer product design, software performance, or infringement of patents or services described herein. Nor does TI warrant or represent that any license, either express or implied, is granted under any patent right, copyright, mask work right, or other intellectual property right of TI covering or relating to any combination, machine, or process in which such semiconductor products or services might be or are used.