



FAST CMOS OCTAL LATCHED TRANSCEIVER

IDT74FCT543T/AT/CT/DT

FEATURES:

- Low input and output leakage $\leq 1\mu\text{A}$ (max.)
- Extended commercial range of -40°C to $+85^{\circ}\text{C}$
- CMOS power levels
- True TTL input and output compatibility
 - $V_{OH} = 3.3\text{V}$ (typ.)
 - $V_{OL} = 0.3\text{V}$ (typ.)
- Meets or exceeds JEDEC standard 18 specifications
- Product available in Radiation Tolerant and Radiation Enhanced versions
- Available in PDIP, SOIC, SSOP, QSOP, and TSSOP packages
- Std., A, C and D speed grades
- High drive outputs (-15mA IOH, 64mA IOL)
- Power off disable outputs permit "live insertion"

DESCRIPTION:

The FCT543T is a non-inverting octal transceiver built using an advanced dual metal CMOS technology. This device contains two sets of eight D-type latches with separate input and output controls for each set. For data flow from A to B, for example, the A-to-B Enable ($\overline{\text{CEAB}}$) input must be low in order to enter data from A_0 - A_7 or to take data from B_0 - B_7 , as indicated in the Function Table. With $\overline{\text{CEAB}}$ low, a low signal on the A-to-B Latch Enable ($\overline{\text{LEAB}}$) input makes the A-to-B latches transparent; a subsequent low-to-high transition of the $\overline{\text{LEAB}}$ signal puts the A latches in the storage mode and their outputs no longer change with the A inputs. With $\overline{\text{CEAB}}$ and $\overline{\text{OEAB}}$ both low, the 3-state B output buffers are active and reflect the data present at the output of the A latches. Control of data from B to A is similar, but uses the $\overline{\text{CEBA}}$, $\overline{\text{LEBA}}$ and $\overline{\text{OEBA}}$ inputs.

FUNCTIONAL BLOCK DIAGRAM

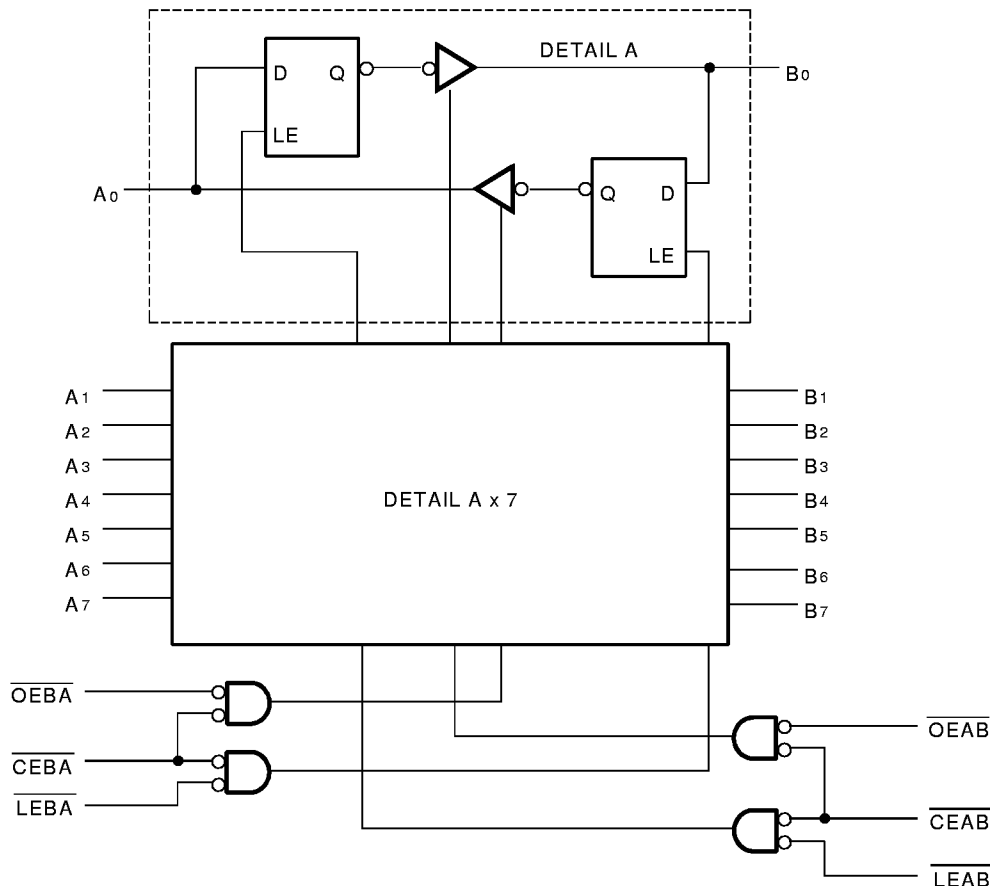

PIN CONFIGURATION

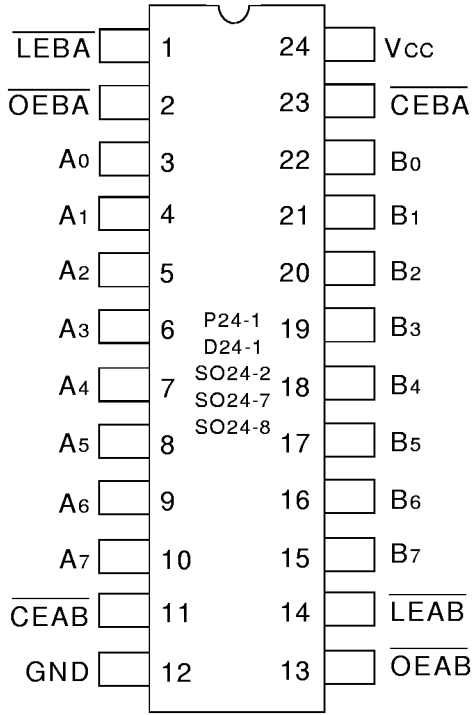

PDIP/ SOIC/ SSOP/ QSOP
TOP VIEW

PIN DESCRIPTION

Pin Names	Description
\overline{OEAB}	A-to-B Output Enable Input (Active LOW)
\overline{OEBA}	B-to-A Output Enable Input (Active LOW)
\overline{CEAB}	A-to-B Enable Input (Active LOW)
\overline{CEBA}	B-to-A Enable Input (Active LOW)
\overline{LEAB}	A-to-B Latch Enable Input (Active LOW)
\overline{LEBA}	B-to-A Latch Enable Input (Active LOW)
A0-A7	A-to-B Data Inputs or B-to-A 3-State Outputs
B0-B7	B-to-A Data Inputs or A-to-B 3-State Outputs

ABSOLUTE MAXIMUM RATINGS(1)

Symbol	Rating	Max.	Unit
$V_{TERM}^{(2)}$	Terminal Voltage with Respect to GND	-0.5 to +7	V
$V_{TERM}^{(3)}$	Terminal Voltage with Respect to GND	-0.5 to $V_{CC}+0.5$	V
TSTG	Storage Temperature	-65 to +150	°C
I _{OUT}	DC Output Current	-65 to +120	mA

8T-link

NOTES:

- Stresses greater than those listed under ABSOLUTE MAXIMUM RATINGS may cause permanent damage to the device. This is a stress rating only and functional operation of the device at these or any other conditions above those indicated in the operational sections of this specification is not implied. Exposure to absolute maximum rating conditions for extended periods may affect reliability. No terminal voltage may exceed V_{CC} by +0.5V unless otherwise noted.
- Inputs and V_{CC} terminals only.
- Outputs and I/O terminals only.

CAPACITANCE ($T_A = +25^\circ\text{C}$, $f = 1.0\text{MHz}$)

Symbol	Parameter ⁽¹⁾	Conditions	Typ.	Max.	Unit
C _{IN}	Input Capacitance	$V_{IN} = 0V$	6	10	pF
C _{OUT}	Output Capacitance	$V_{OUT} = 0V$	8	12	pF

8T-link

NOTE:

- This parameter is measured at characterization but not tested.

FUNCTION TABLE(1,2)

For A-to-B (Symmetric with B-to-A)

Inputs			Latch Status	Output Buffers
\overline{CEAB}	\overline{LEAB}	\overline{OEAB}	A-to-B	B0-B7
H	—	—	Storing	High Z
—	H	—	Storing	—
—	—	H	—	High Z
L	L	L	Transparent	Current A Inputs
L	H	L	Storing	Previous* A Inputs

NOTES:

- * Before \overline{LEAB} LOW-to-HIGH Transition
H = HIGH Voltage Level
L = LOW Voltage Level
— = Don't Care
- A-to-B data flow shown; B-to-A flow control is the same, except using \overline{CEBA} , \overline{LEBA} and \overline{OEBA} .

DC ELECTRICAL CHARACTERISTICS OVER OPERATING RANGE

Following Conditions Apply Unless Otherwise Specified:

Commercial: $T_A = -40^\circ\text{C}$ to $+85^\circ\text{C}$, $V_{CC} = 5.0\text{V} \pm 5\%$

Symbol	Parameter	Test Conditions ⁽¹⁾	Min.	Typ. ⁽²⁾	Max.	Unit
V_{IH}	Input HIGH Level	Guaranteed Logic HIGH Level	2	—	—	V
V_{IL}	Input LOW Level	Guaranteed Logic LOW Level	—	—	0.8	V
I_{IH}	Input HIGH Current ⁽⁴⁾	$V_{CC} = \text{Max.}$ $V_I = 2.7\text{V}$	—	—	± 1	μA
I_{IL}	Input LOW Current ⁽⁴⁾		$V_I = 0.5\text{V}$	—	—	
I_{OZH}	High Impedance Output Current (3-State output pins) ⁽⁴⁾	$V_{CC} = \text{Max.}$ $V_O = 2.7\text{V}$	—	—	± 1	μA
I_{OZL}			$V_O = 0.5\text{V}$	—	—	
I_I	Input HIGH Current	$V_{CC} = \text{Max.}, V_I = V_{CC} (\text{Max.})$	—	—	± 1	μA
V_{IK}	Clamp Diode Voltage	$V_{CC} = \text{Min.}, I_{IN} = -18\text{mA}$	—	-0.7	-1.2	V
V_H	Input Hysteresis	—	—	200	—	mV
I_{CC}	Quiescent Power Supply Current	$V_{CC} = \text{Max.}, V_{IN} = \text{GND or } V_{CC}$	—	0.01	1	μA

OUTPUT DRIVE CHARACTERISTICS

Symbol	Parameter	Test Conditions ⁽¹⁾	Min.	Typ. ⁽²⁾	Max.	Unit	
V_{OH}	Output HIGH Voltage	$V_{CC} = \text{Min.}$ $V_{IN} = V_{IH} \text{ or } V_{IL}$	$I_{OH} = -8\text{mA}$	2.4	3.3	—	V
			$I_{OH} = -15\text{mA}$	2	3	—	
V_{OL}	Output LOW Voltage	$V_{CC} = \text{Min.}$ $V_{IN} = V_{IH} \text{ or } V_{IL}$	—	0.3	0.55	V	
I_{OS}	Short Circuit Current	$V_{CC} = \text{Max.}, V_O = \text{GND}^{(3)}$	-60	-120	-225	mA	
I_{OFF}	Input/Output Power Off Leakage ⁽⁵⁾	$V_{CC} = 0\text{V}, V_{IN} \text{ or } V_O \leq 4.5\text{V}$	—	—	± 1	μA	

NOTES:

1. For conditions shown as max. or min., use appropriate value specified under Electrical Characteristics for the applicable device type.
2. Typical values are at $V_{CC} = 5.0\text{V}$, $+25^\circ\text{C}$ ambient and maximum loading.
3. Not more than one output should be shorted at one time. Duration of the short circuit test should not exceed one second.
4. The test limit for this parameter is $\pm 5\mu\text{A}$ at $T_A = -55^\circ\text{C}$.
5. This parameter is guaranteed but not tested.

POWER SUPPLY CHARACTERISTICS

Symbol	Parameter	Test Conditions ⁽¹⁾		Min.	Typ. ⁽²⁾	Max.	Unit
ΔI_{CC}	Quiescent Power Supply Current TTL Inputs HIGH	$V_{CC} = \text{Max.}$ $V_{IN} = 3.4V^{(3)}$		—	0.5	2	mA
I_{CCD}	Dynamic Power Supply Current ⁽⁴⁾	$V_{CC} = \text{Max.}$, Outputs Open \overline{CEAB} and $\overline{OEAB} = \text{GND}$ $\overline{CEBA} = V_{CC}$ One Input Toggling 50% Duty Cycle	$V_{IN} = V_{CC}$ $V_{IN} = \text{GND}$	—	0.15	0.25	mA/ MHz
I_C	Total Power Supply Current ⁽⁶⁾	$V_{CC} = \text{Max.}$, Outputs Open $f_{CP} = 10\text{MHz}$ (\overline{LEAB}) 50% Duty Cycle \overline{CEAB} and $\overline{OEAB} = \text{GND}$ $\overline{CEBA} = V_{CC}$ One Bit Toggling at $f_i = 5\text{MHz}$ 50% Duty Cycle	$V_{IN} = V_{CC}$ $V_{IN} = \text{GND}$	—	1.5	3.5	mA
			$V_{IN} = 3.4V$ $V_{IN} = \text{GND}$	—	2	5.5	
		$V_{CC} = \text{Max.}$, Outputs Open $f_{CP} = 10\text{MHz}$ (\overline{LEAB}) 50% Duty Cycle \overline{CEAB} and $\overline{OEAB} = \text{GND}$ $\overline{CEBA} = V_{CC}$ Eight Bits Toggling at $f_i = 2.5\text{MHz}$ 50% Duty Cycle	$V_{IN} = V_{CC}$ $V_{IN} = \text{GND}$	—	3.8	7.3 ⁽⁵⁾	
			$V_{IN} = 3.4V$ $V_{IN} = \text{GND}$	—	6	16.3 ⁽⁵⁾	

NOTES:

- For conditions shown as Max. or Min., use appropriate value specified under Electrical Characteristics for the applicable device type.
- Typical values are at $V_{CC} = 5.0V$, $+25^\circ\text{C}$ ambient.
- Per TTL driven input ($V_{IN} = 3.4V$). All other inputs at V_{CC} or GND .
- This parameter is not directly testable, but is derived for use in Total Power Supply Calculations.
- Values for these conditions are examples of the I_{CC} formula. These limits are guaranteed but not tested.
- $I_C = I_{QUIESCENT} + I_{INPUTS} + I_{DYNAMIC}$
 $I_C = I_{CC} + \Delta I_{CC} D_{HNT} + I_{CCD} (f_{CP}/2 + f_i N_i)$
 I_{CC} = Quiescent Current
 ΔI_{CC} = Power Supply Current for a TTL High Input ($V_{IN} = 3.4V$)
 D_H = Duty Cycle for TTL Inputs High
 N_T = Number of TTL Inputs at D_H
 I_{CCD} = Dynamic Current Caused by an Input Transition Pair (HLH or LHL)
 f_{CP} = Clock Frequency for Register Devices (Zero for Non-Register Devices)
 f_i = Input Frequency
 N_i = Number of Inputs at f_i
 All currents are in milliamps and all frequencies are in megahertz.

SWITCHING CHARACTERISTICS OVER OPERATING RANGE

Symbol	Parameter	Condition ⁽¹⁾	FCT543T		FCT543AT		FCT543CT		FCT543DT		Unit
			Min. ⁽²⁾	Max.	Min. ⁽²⁾	Max.	Min. ⁽²⁾	Max.	Min. ⁽²⁾	Max.	
tPLH tPHL	Propagation Delay Transparent Mode An to Bn or Bn to An	CL = 50pF RL = 500Ω	1.5	8.5	1.5	6.5	1.5	5.3	1.5	4.4	ns
tPLH tPHL	Propagation Delay \overline{LEBA} to An, \overline{LEAB} to Bn		1.5	12.5	1.5	8	1.5	7	1.5	5	ns
tPZH tPZL	Output Enable Time \overline{OEBA} or \overline{OEAB} to An or Bn \overline{CEBA} or \overline{CEAB} to An or Bn		1.5	12	1.5	9	1.5	8	1.5	5.4	ns
tPHZ tPLZ	Output Disable Time \overline{OEBA} or \overline{OEAB} to An or Bn \overline{CEBA} or \overline{CEAB} to An or Bn		1.5	9	1.5	7.5	1.5	6.5	1.5	4.3	ns
tsu	Set-up Time, HIGH or LOW An or Bn to \overline{LEBA} or \overline{LEAB}		3	—	2	—	2	—	1.5	—	ns
tH	Hold Time, HIGH or LOW An or Bn to \overline{LEBA} or \overline{LEAB}		2	—	2	—	2	—	1.5	—	ns
tw	\overline{LEBA} or \overline{LEAB} Pulse Width LOW		5	—	5	—	5	—	3 ⁽³⁾	—	ns

NOTES:

1. See test circuits and waveforms.
2. Minimum limits are guaranteed but not tested on Propagation Delays.
3. This limit is guaranteed but not tested.

TEST CIRCUITS AND WAVEFORMS

TEST CIRCUITS FOR ALL OUTPUTS

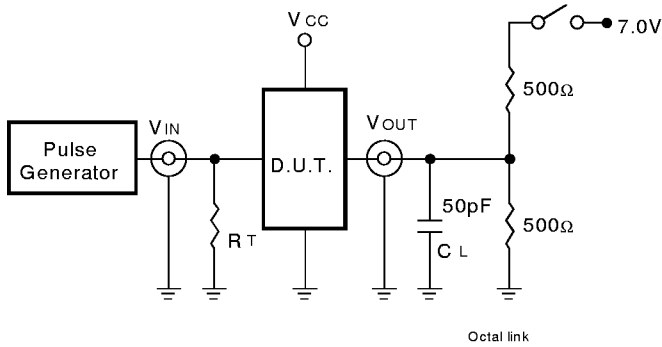

Octal link

SWITCH POSITION

Test	Switch
Open Drain	Closed
Disable Low	
Enable Low	
All Other Tests	Open

8-link

DEFINITIONS:

C_L = Load capacitance: includes jig and probe capacitance.

R_T = Termination resistance: should be equal to Z_{OUT} of the Pulse Generator.

SET-UP, HOLD, AND RELEASE TIMES

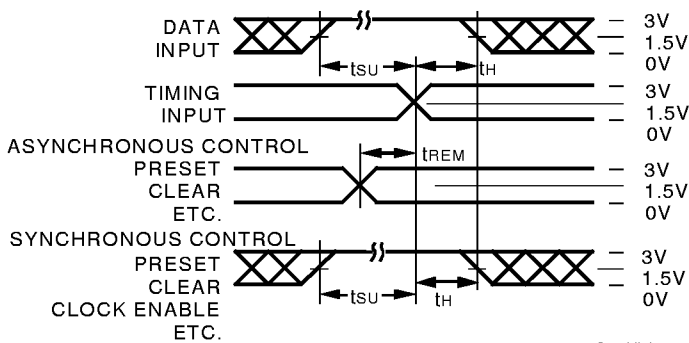

Octal link

PULSE WIDTH

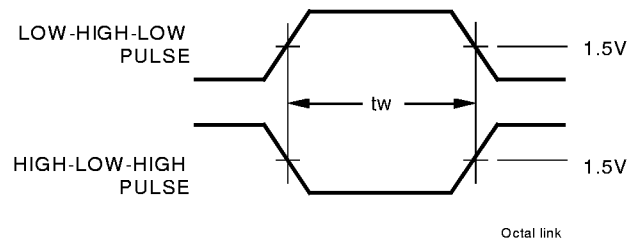

Octal link

PROPAGATION DELAY

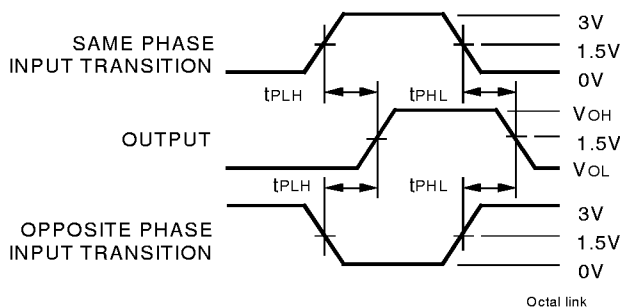

Octal link

ENABLE AND DISABLE TIMES

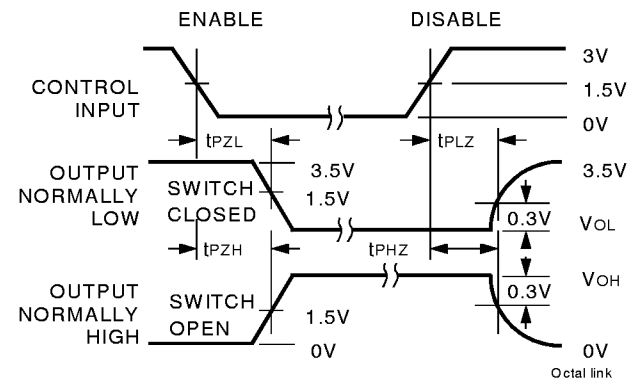

Octal link

NOTES:

- Diagram shown for input Control Enable-LOW and input Control Disable-HIGH
- Pulse Generator for All Pulses: Rate $\leq 1.0\text{MHz}$; $t_F \leq 2.5\text{ns}$; $t_R \leq 2.5\text{ns}$

ORDERING INFORMATION

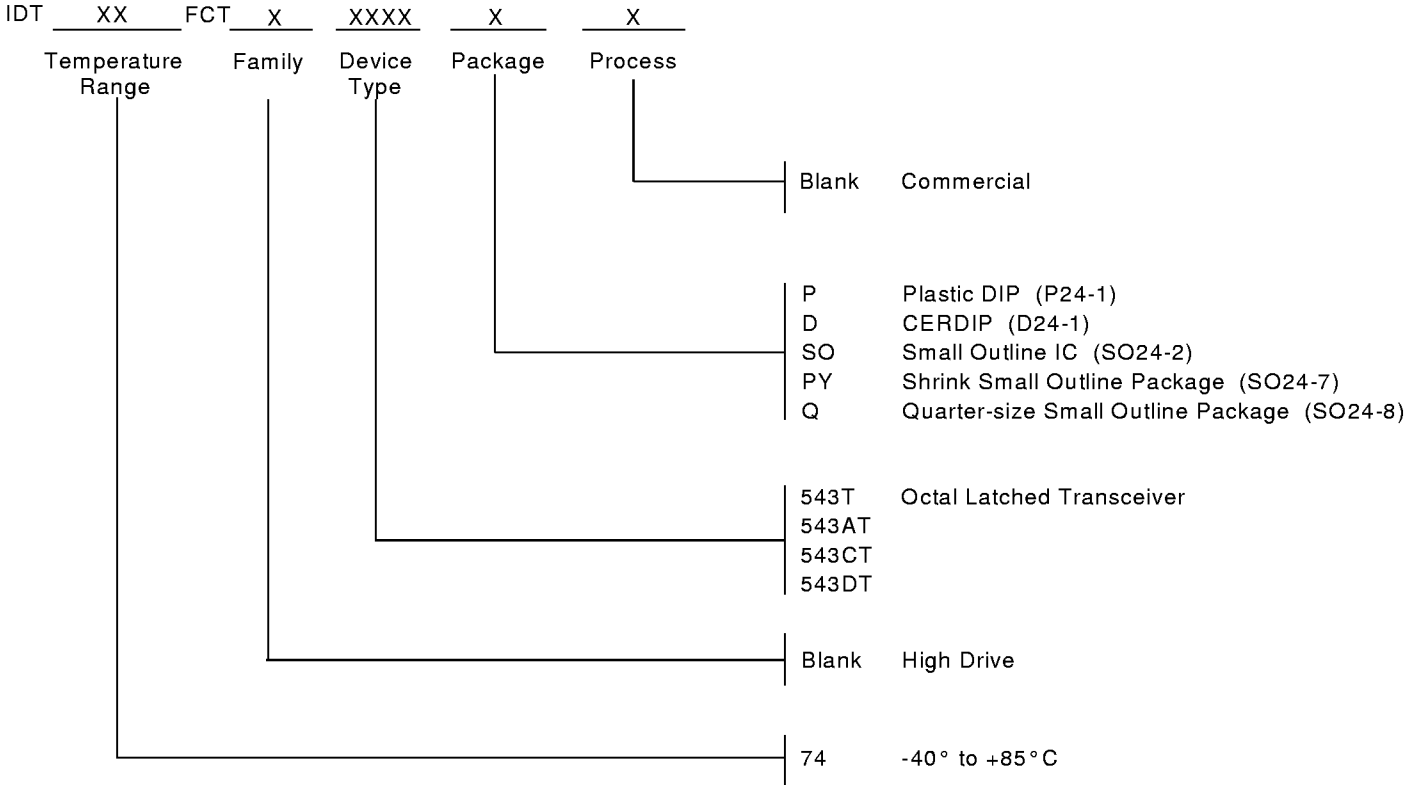

CORPORATE HEADQUARTERS
 2975 Stender Way
 Santa Clara, CA 95054

for SALES:
 800-345-7015 or 408-727-6116
 fax: 408-492-8674
 www.idt.com*

*To search for sales office near you, please click the sales button found on our home page or dial the 800# above and press 2.
 The IDT logo is a registered trademark of Integrated Device Technology, Inc.