



PI6C102-16

Spread Spectrum Clock Synthesizer for Mobile Pentium II

Features

- 100 MHz or 66.6 MHz operation
- Two copies of CPU clock with V_{DD} of 2.5V
- High drive option to support modular mobile CPUs
- Six copies of PCI clock, (synchronous with CPU clock) 3.3V
- One copy of Ref. Clock @ 14.31818 MHz (3.3VTTL)
- One copy of 48 MHz Clock (3.3V)
- Low cost 14.31818 MHz crystal oscillator input
- Power management control
- Isolated core V_{DD} , V_{SS} pins for noise reduction
- Down spread (-16) or center spread spectrum (-16B) options
- 28-pin SSOP package (H)

Description

Pericom Semiconductor's PI6C clock series are produced using the company's advanced submicron CMOS technology, achieving industry leading speed.

PI6C102-16 is a high-speed, low-noise, clock generator that works with Pericom's PI6C18x clock buffer to meet all clock needs for Mobile Intel Architecture platforms. CPU and chipset clock frequencies of 66.6 MHz and 100 MHz are supported.

Split supplies of 3.3V and 2.5V are used. The 3.3V power supply powers a portion of the I/O and the core. The 2.5V is used to power the remaining outputs. 2.5V signaling follows JEDEC standard 8-X. Power sequencing of the 3.3V and 2.5V supplies is not required.

An asynchronous PWRDWN# signal may be used to orderly power down (or up) the system.

PI6C102-16 is -0.6% down spread, where as PI6C102-16B is $\pm 0.75\%$ center spread.

PI6C102-16D is the high drive version of PI6C102-16

Block Diagram

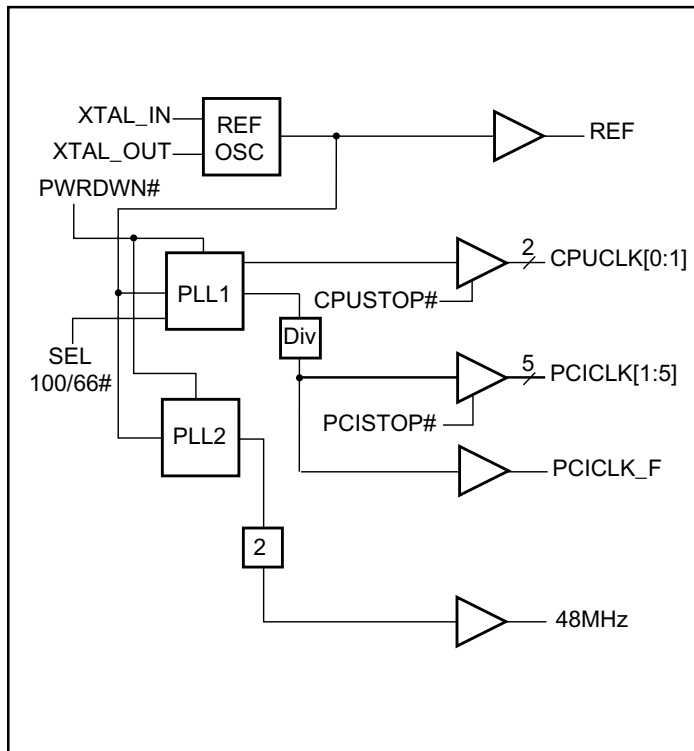

Pin Configuration

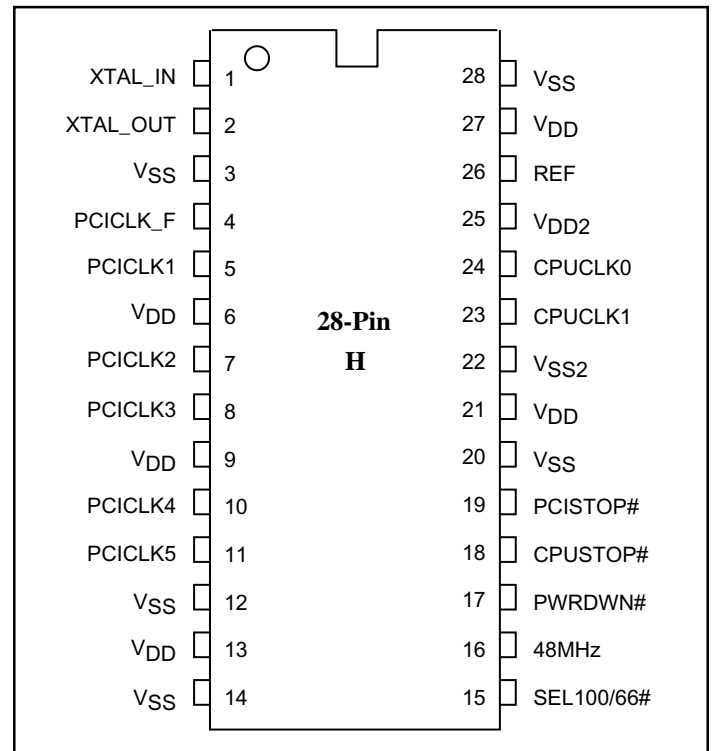



Pin Description

Pin	Signal Name	Type	Qty.	Description
1	XTAL_IN	I	1	14.318 MHz crystal input
2	XTAL_OUT	O	1	14.318 MHz crystal output
4	PCICLK_F	O	1	Free running PCI clock output
5,7,8,10,11	PCICLK[1:5]	O	5	PCI clock outputs, TTL compatible
15	SEL100/66#	I	1	Select 100 MHz or 66 MHz. H = 100 MHz , L = 66 MHz
16	48MHz	O	1	48 MHz output
17	PWRDWN#	I	1	Powers down device when held LOW (Internal Pull up)
18	CPUSTOP#	I	1	Stops CPU clocks LOW if held LOW (Internal Pull up)
19	PCISTOP#	I	1	Stops PCI clocks LOW if held LOW (Internal Pull up)
22	V _{SS2}	ground	1	Ground for CPU outputs, 2.5V
23,24	CPUCLK[0:1]	O	2	CPU and Host clock outputs, 2.5V
25	V _{DD2}	power	1	Power for CPU outputs, 2.5V
26	REF	O	1	14.318 MHz clock output
6,9,13,21,27	V _{DD}	power	5	3.3V Power
3,12,14,20,28	V _{SS}	ground	5	3.3V Ground

Select Functions

SEL100/66#	CPUCLK[0:1]
0	66 MHz
1	100 MHz

Clock Enable Configuration

CPU_STOP#	PCL_STOP#	PWR_DWN#	CPUCLK [0:1]	PCICLK [1:5]	PCICLK_F	Other Clocks	Crystal	VCO's	48MHz
X	X	0	low	low	low	stopped	off	off	off
0	0	1	low	low	33MHz	running	running	running	running
0	1	1	low	33MHz	33MHz	running	running	running	running
1	0	1	100/66MHz	low	33MHz	running	running	running	running
1	1	1	100/66MHz	33MHz	33MHz	running	running	running	running

Power Management Timing

Signal	Signal State	Latency
		No. of rising edges of free running PCICLK
CPU_STOP#	0 (disabled)	1
	1 (enabled)	1
PCI_STOP#	0 (disabled)	1
	1 (enabled)	1
PWR_DWN#	1 (normal operation)	3ms
	0 (power down)	2 max.

Notes:

1. Clock on/off latency is defined as the number of rising edges of free running PCICLKs between when the clock disable goes low/high to when the first valid clock comes out of the device.
2. Power-up latency is from when PWR_DWN# goes inactive (HIGH) to when the first valid clocks are driven from the device.

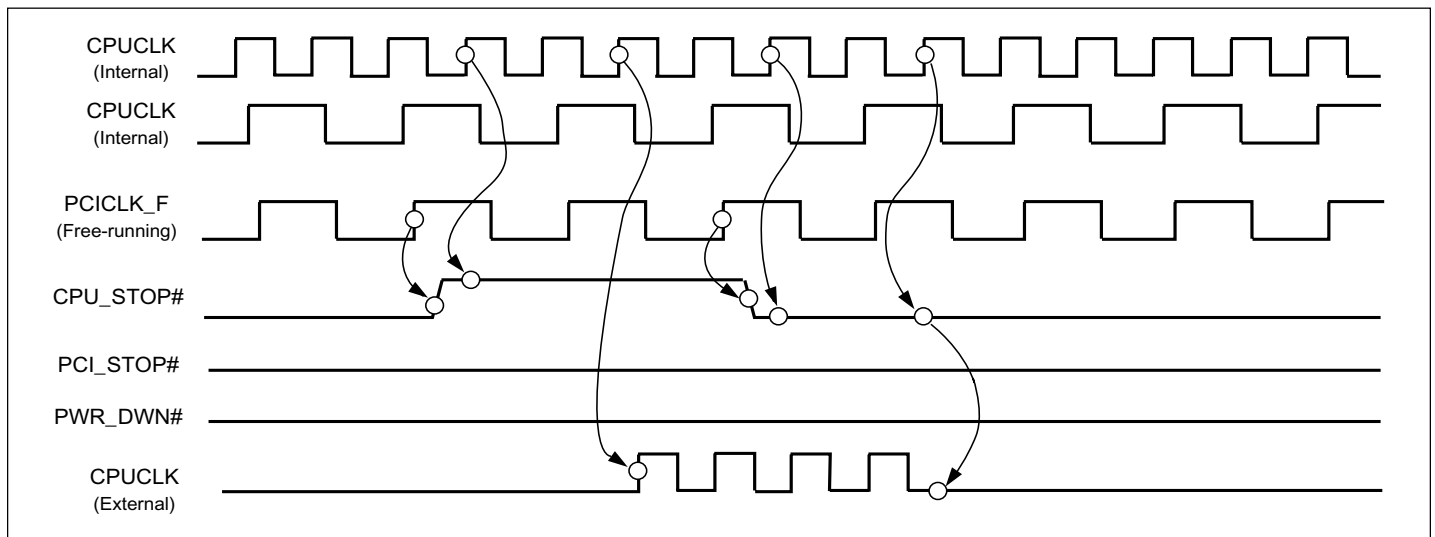

CPU_STOP# Timing Diagram

Notes:

1. All timing is referenced to the CPUCLK.
2. The Internal label means inside the chip and is a reference only.
- 3 CPU_STOP# is an input signal that must be made synchronous to the free running PCI_F.
4. ON/OFF latency shown in the diagram is 2 CPU clocks.
5. All other clocks continue to run undisturbed.
6. PWR_DWN# and PCI_STOP# are shown in a HIGH state.
7. Diagrams shown with respect to 66 MHz. Similar operation as CPU = 100 MHz.

PCI_STOP# is an input signal used to turn off PCI clocks for low power operation. PCI clocks are stopped in the LOW state and started with a guaranteed full high pulse width. There is ONLY one rising edge of external PCICLK after the clock control logic.

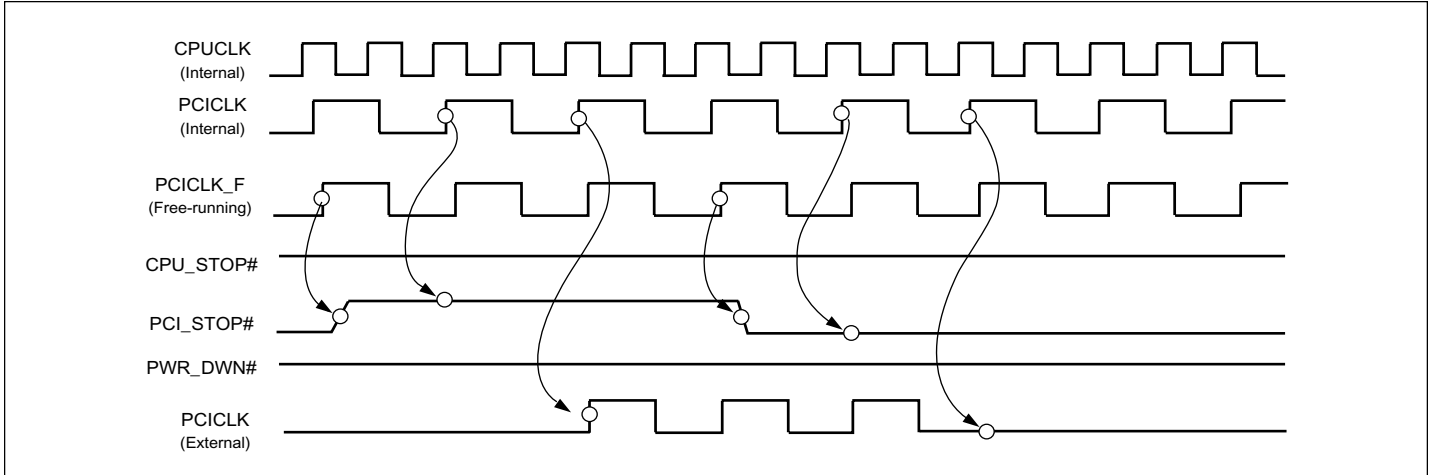

PCI_STOP# Timing Diagram

Notes:

1. All timing is referenced to the CPUCLK.
2. PCI_STOP# signal is an input signal which must be made synchronous to PCI_F output.
- 3 Internal means inside the chip.
4. All other clocks continue to run undisturbed.
5. PWR_DWN# and CPU_STOP# are shown in a high state.
6. Diagrams shown with respect to 66MHz. Similar operation as CPU = 100 MHz.

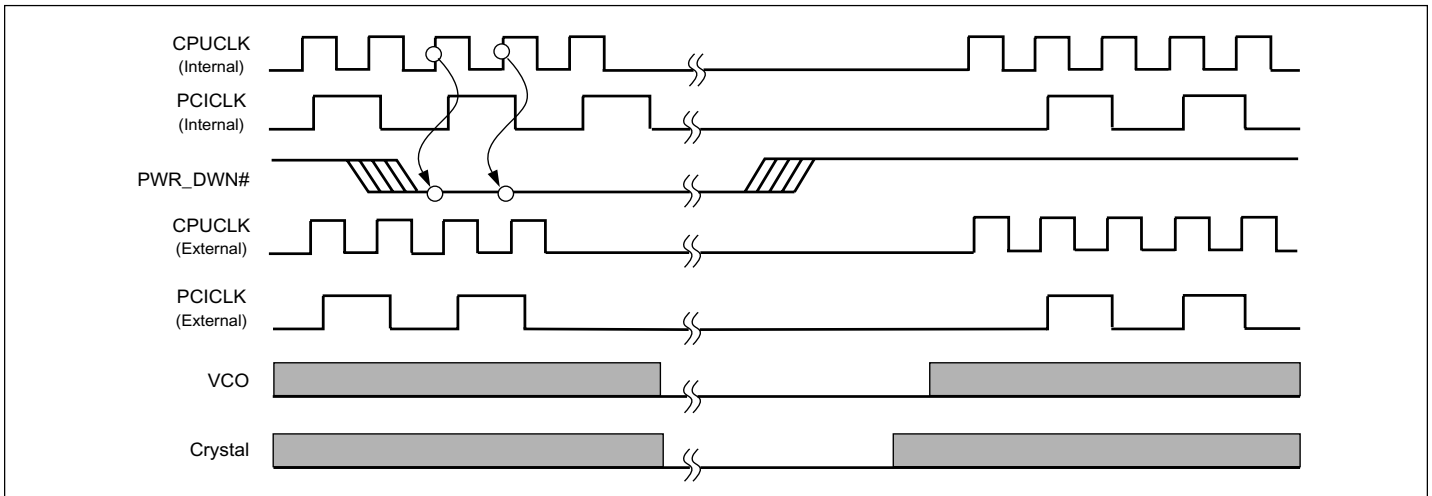

PWR_DWN# Timing Diagram

Notes:

1. All timing is referenced to the CPUCLK.
2. The Internal label means inside the chip and is a reference only.
3. PWR_DWN# is an asynchronous input and metastable conditions could exist. The signal is synchronized inside the part.
4. The shaded sections on the VCO and the Crystal signals indicate an active clock.
5. Diagrams shown with respect to 66 MHz. Similar operation as CPU = 100 MHz.



CPU_STOP# is an input signal used to turn off the CPU clocks for low power operation. CPU_STOP# is asserted asynchronously by the external clock control logic with the rising edge of free running PCI clock and is internally synchronized to the external PCICLK_F output. All other clocks continue to run while the CPU clocks are disabled. The CPU clocks are always stopped in a LOW state and started guaranteeing that the high pulse width is a full pulse. CPU clock on latency is 2 or 3 CPU clocks and CPU clock off latency is 2 or 3 CPU clocks.

The PWR_DWN# is used to place the device in a very low power state. PWR_DWN# is an asynchronous active low input. Internal clocks are stopped after the device is put in power-down mode. The power-on latency is less than 3ms. PCI_STOP# and CPU_STOP# are “don’t cares” during the power-down operations. The REF clock is stopped in the LOW state as soon as possible.

Maximum Ratings

(Above which the useful life may be impaired. For user guidelines, not tested.)

Storage Temperature	-65°C to +150°C
Ambient Temperature with Power Applied	-0°C to +70°C
3.3V Supply Voltage to Ground Potential	-0.5V to +4.6V
2.5V Supply Voltage to Ground Potential	-0.5V to +3.6V
DC Input Voltage	-0.5V to +4.6V

Note:

Stresses greater than those listed under MAXIMUM RATINGS may cause permanent damage to the device. This is a stress rating only and functional operation of the device at these or any other conditions above those indicated in the operational sections of this specification is not implied. Exposure to absolute maximum rating conditions for extended periods may affect reliability.

DC Electrical Characteristics ($V_{DD} = +3.3V \pm 5\%$, $V_{DD2} = +2.5V \pm 5\%$, $T_A = 0^\circ C$ to $+70^\circ C$)

PI6C102-16 Condition	Max. 2.5V Supply Consumption Max. discrete cap loads, $V_{DD2} = 2.625V$ All static inputs = V_{DD} or V_{SS}	Max. 3.3V Supply Consumption Max. discrete cap loads, $V_{DD} = 3.465V$ All static inputs = V_{DD} or V_{SS}
Powerdown Mode (PWRDWN# = 0)	100µA	500µA
Active 66MHz SEL 100/66# = 0	72mA	170mA
Active 100MHz SEL 100/66# = 1	100mA	170mA

DC Operating Specifications

Symbol	Parameters	Conditions	Min.	Max.	Units
V_{DD} = 3.3V ± 5%					
V _{IH}	Input high voltage	V _{DD}	2.0	V _{DD} + 0.3	V
V _{IL}	Input low voltage		V _{SS} - 0.3	0.8	
I _{IL}	Input leakage current	0 < V _{IN} < V _{DD}	-5	+5	μA
V_{DD} = 2.5V ± 5%					
V _{OH2}	Output high voltage	I _{OH} = -1mA	2.0		V
V _{OL2}	Output low voltage	I _{OL} = 1mA		0.4	
V_{DD} = 3.3V ± 5%					
V _{OH}	Output high voltage	I _{OH} = -1mA	2.4		V
V _{OL}	Output low voltage	I _{OL} = 1mA		0.4	
V_{DD} = 3.3V ± 5%					
V _{POH}	PCI Bus output high voltage	I _{OH} = -1mA	2.4		V
V _{POL}	PCI Bus output low voltage	I _{OL} = 1mA		0.55	
C _{IN}	Input pin capacitance			5	pF
C _{XTAL}	Xtal pins capacitance	13.5	18.0	22.5	
C _{OUT}	Output pin capacitance			6	
L _{PIN}	Pin Inductance			7	nH
T _A	Ambient Temperature	No airflow	0	70	°C

Buffer Specifications

Buffer Name	V _{DD} Range(V)	Impedance (Ω)	Buffer Type
CPU	2.375 - 2.625	13.5 - 45	Type 1
REF, 48 MHz	3.135 - 3.465	20 - 60	Type 3
PCI	3.135 - 3.465	12 - 55	Type 5

Type 1: CPU Clock Buffers (2.5V) for PI6C102-16 and PI6C102-16B

Symbol	Parameters	Conditions	Min.	Typ.	Max.	Units
I _{OHMIN}	Pull-up current	V _{OUT} = 1.0V	-27			mA
I _{OHMAX}	Pull-up current	V _{OUT} = 2.375V			-27	
I _{OLMIN}	Pull-down current	V _{OUT} = 1.2V	27			
I _{OLMAX}	Pull-down current	V _{OUT} = 0.3V			30	
t _{RH}	2.5V Type 1 output rise edge rate	2.5V ± 5% @ 0.4V-2.0V	1		4	V/ns
t _{FH}	2.5V Type 1 output fall edge rate	2.5V ± 5% @ 2.0V-0.4V	1		4	

Type 1H: CPU Clock Buffers (2.5V) for PI6C102-16D

Symbol	Parameters	Conditions	Min.	Typ.	Max.	Units
I _{OHMIN}	Pull-up current	V _{OUT} = 1.0V	-54			mA
I _{OHMAX}	Pull-up current	V _{OUT} = 2.375V			-54	
I _{OLMIN}	Pull-down current	V _{OUT} = 1.2V	54			
I _{OLMAX}	Pull-down current	V _{OUT} = 0.3V			60	
t _{RH}	2.5V Type 1H output rise edge rate	2.5V ± 5% @ 0.4V-2.0V	1		4	V/ns
t _{FH}	2.5V Type 1H output fall edge rate	2.5V ± 5% @ 2.0V-0.4V	1		4	

Type 3: REF, 48MHz Buffers (3.3V)

Symbol	Parameters	Conditions	Min.	Typ.	Max.	Units
I _{OHMIN}	Pull-up current	V _{OUT} = 1.0V	-29			mA
I _{OHMAX}	Pull-up current	V _{OUT} = 2.375V			-23	
I _{OLMIN}	Pull-down current	V _{OUT} = 1.2V	29			
I _{OLMAX}	Pull-down current	V _{OUT} = 0.3V			27	
t _{RH}	3.3V Type 3 output rise edge rate	3.3V ± 5% @ 0.4V-2.4V	0.5		2	V/ns
t _{FH}	3.3V Type 3 output fall edge rate	3.3V ± 5% @ 2.4V-0.4V	0.5		2	

Type 5: PCI Clock Buffers (3.3V)

Symbol	Parameters	Conditions	Min.	Typ.	Max.	Units
I _{OHMIN}	Pull-up current	V _{OUT} = 1.0V	-33			mA
I _{OHMAX}	Pull-up current	V _{OUT} = 3.135V			-33	
I _{OLMIN}	Pull-down current	V _{OUT} = 1.95V	30			
I _{OLMAX}	Pull-down current	V _{OUT} = 0.4V			38	
t _{RH}	3.3V Type 5 output rise edge rate	3.3V ± 5% @ 0.4V-2.4V	1		4	V/ns
t _{FH}	3.3V Type 5 output fall edge rate	3.3V ± 5% @ 2.4V-0.4V	1		4	

AC Timing

Figure 1. Host Clock to PCI CLK Offset	Parameters	66 MHz		100 MHz		Units
		Min.	Max.	Min.	Max.	
t _{HKP} (2.5V)	Host CLK period	15.0	15.5	10.0	10.5	ns
t _{HKH} (2.5V)	Host CLK high time	5.2		3.0		
t _{HKL} (2.5V)	Host CLK low time	5.0		2.8		
t _{HRISE} (2.5V)	Host CLK rise time	0.4	1.6	0.4	1.6	
t _{HFALL} (2.5V)	Host CLK fall time	0.4	1.6	0.4	1.6	
t _{JITTER} (2.5V)	Host CLK Jitter		250		250	ps
Duty Cycle (2.5V)	Measured at 1.25V	45	55	45	55	%
t _{HSKW} (2.5V)	Host Bus CLK Skew		175		175	ps
t _{PZL} , t _{PZH}	Output enable delay	1.0	8.0	1.0	8.0	ns
t _{PLZ} , t _{PHZ}	Output disable delay	1.0	8.0	1.0	8.0	
t _{HSTB}	Host CLK Stabilization from power-up		3		3	ms
t _{PKP}	PCI CLK period	30.0	∞	30.0	∞	ns
t _{PKPS}	PCI CLK period stability		500		500	ps
t _{PKH}	PCI CLK high time	12.0		12.0		ns
t _{PKL}	PCI CLK low time	12.0		12.0		
t _{PSKW}	PCI Bus CLK Skew		500		500	ps
t _{HPOFFSET}	Host to PCI Clock Offset	1.5	4.0	1.5	4.0	ns
t _{PSTB}	PCI CLK Stabilization from power-up		3		3	ms

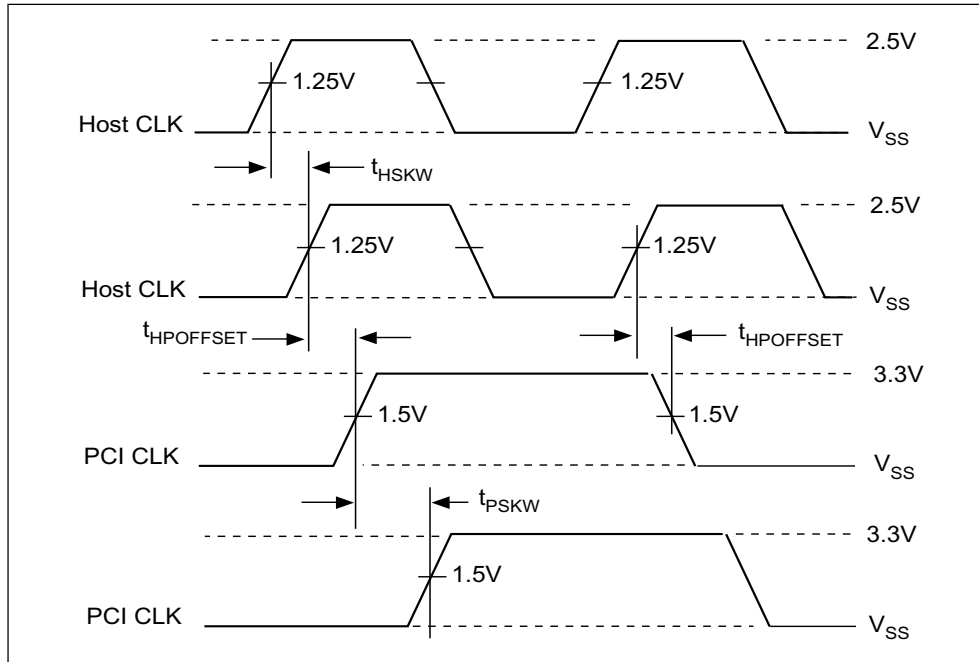

Host Clock and PCI CLK Timing

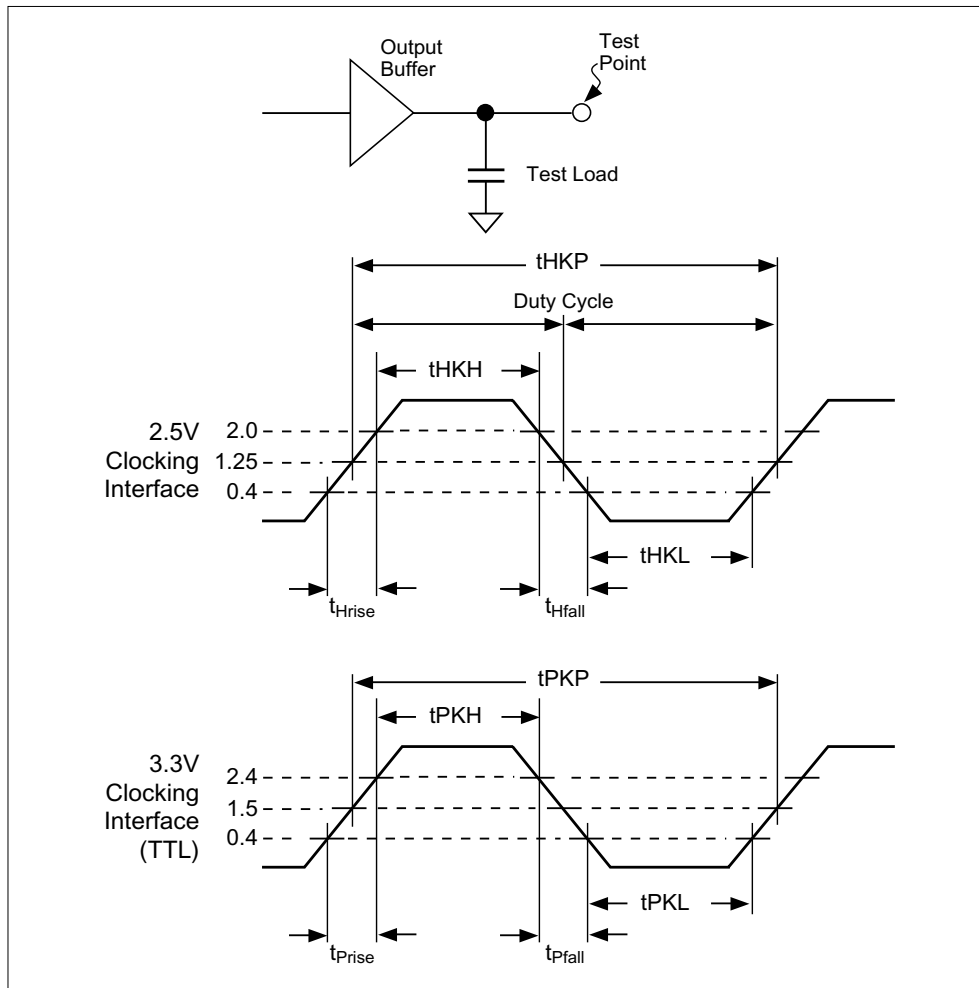

Clock Output Waveforms

Minimum and Maximum Expected Capacitive Loads

Clock	Min. Load	Max. Load	Units	Notes
CPU Clocks (HCLK)	10	20	pF	1 device load, possible 2 loads
PCI Clocks (PCLK)	30	30		Meets PCI 2.1 requirements
REF, 48MHz	10	20		1 device load

Notes:

1. Maximum rise/fall times are guaranteed at maximum specified load for each type of output buffer.
2. Minimum rise/fall times are guaranteed at minimum specified load for each type of output buffer.
3. Rise/fall times are specified with pure capacitive load as shown. Testing is done with an additional 500Ω resistor in parallel.

Design Guidelines to Reduce EMI

1. Place series resistors and CI capacitors as close as possible to the respective clock pins. Typical value for CI is 10pF. Series resistor value can be increased to reduce EMI provided that the rise and fall time are still within the specified values.
2. Minimize the number of “vias” of the clock traces.
3. Route clock traces over a continuous ground plane or over a continuous power plane. Avoid routing clock traces from plane to plane (refer to rule #2).
4. Position clock signals away from signals that go to any cables or any external connectors.

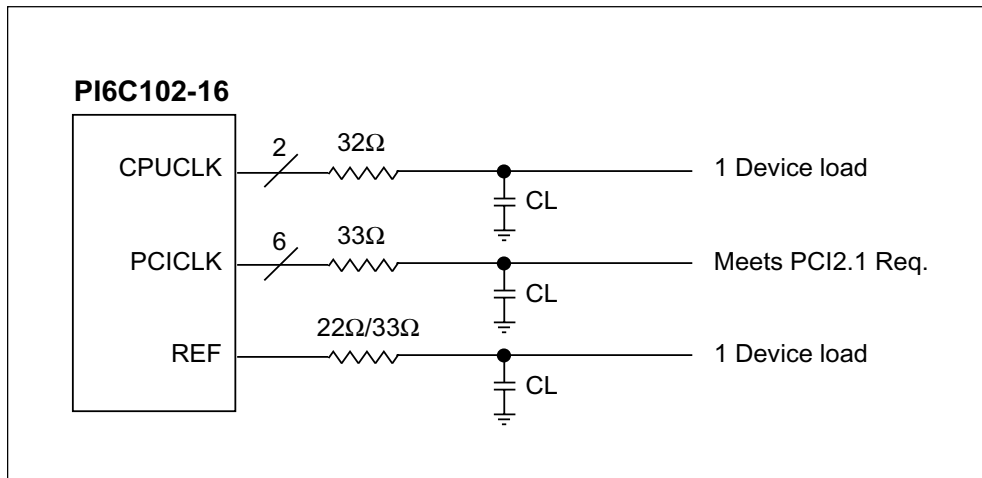

PCB Layout Suggestion

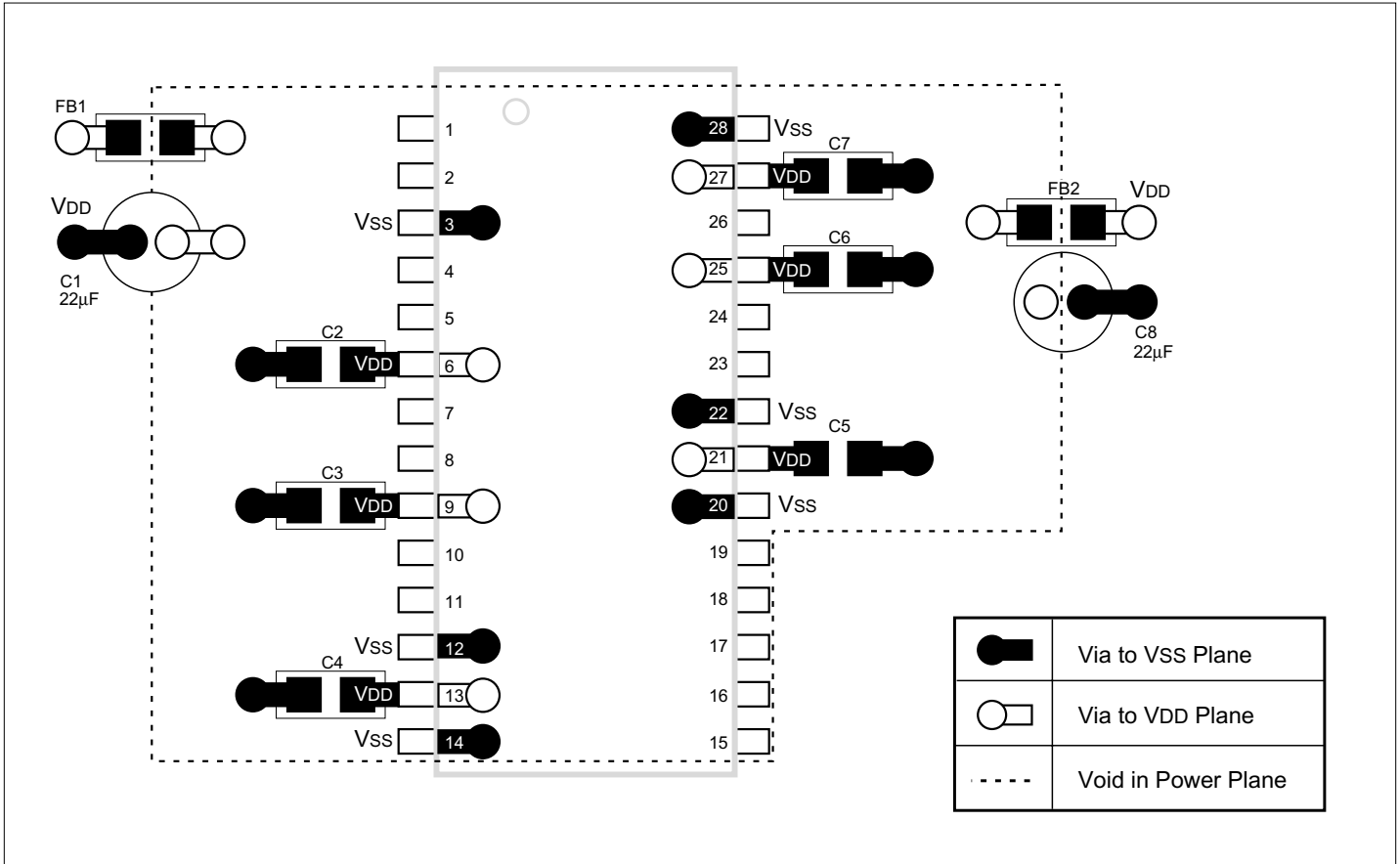

Note:

This is only a suggested layout. There may be alternate solutions depending on actual PCB design and layout.

As a general rule, C2-C7 should be placed as close as possible to their respective V_{DD}.

Recommended capacitor values:

C2-C7 0.1µF, ceramic

C1, C8 22µF

28-Pin SSOP Package Data

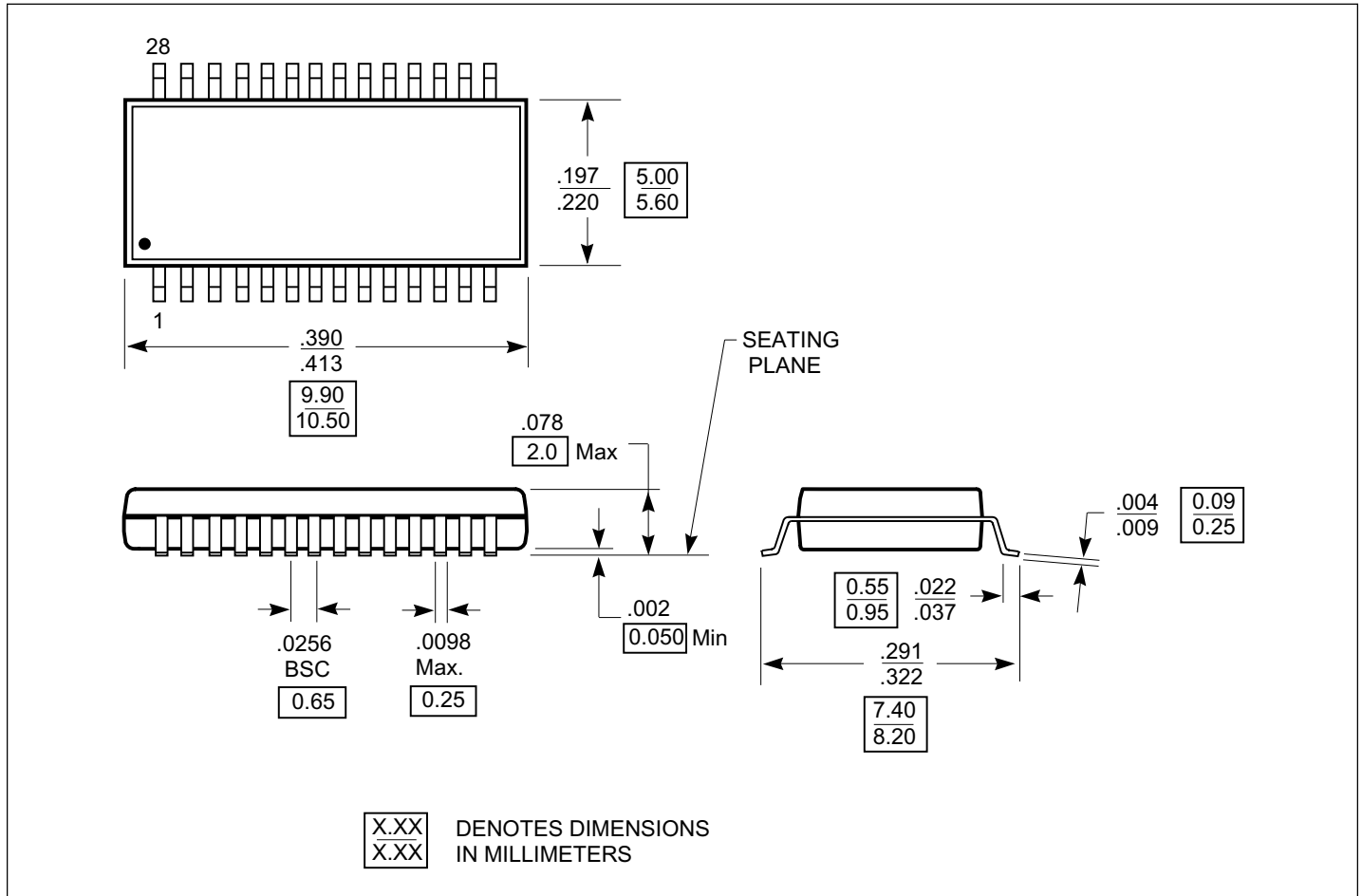

Ordering Information

P/N	Description
PI6C102-16H	28-pin SSOP Package
PI6C102-16BH	
PI6C102-16DH	