

## 32M-Bit (4Mx8 /2Mx16) CMOS MASK ROM

### FEATURES

- Switchable organization  
4,194,304x8(byte mode)  
2,097,152x16(word mode)
- Fast access time  
3.3V Operation : 120ns(Max.)  
3.0V Operation : 150ns(Max.)
- Supply voltage : single +3.0V/ single +3.3V
- Current consumption  
Operating : 40mA(Max.)  
Standby : 30μA(Max.)
- Fully static operation
- All inputs and outputs TTL compatible
- Three state outputs
- Package  
-. KM23V32000C(E)T : 44-TSOP2-400

### GENERAL DESCRIPTION

The KM23V32000C(E)T is a fully static mask programmable ROM fabricated using silicon gate CMOS process technology, and is organized either as 4,194,304x8 bit(byte mode) or as 2,097,152x16 bit(word mode) depending on BHE voltage level.(See mode selection table)

This device operates with 3.0V or 3.3V power supply, and all inputs and outputs are TTL compatible.

Because of its asynchronous operation, it requires no external clock assuring extremely easy operation.

It is suitable for use in program memory of microprocessor, and data memory, character generator.

The KM23V32000C(E)T is packaged in a 44-TSOP2.

### FUNCTIONAL BLOCK DIAGRAM

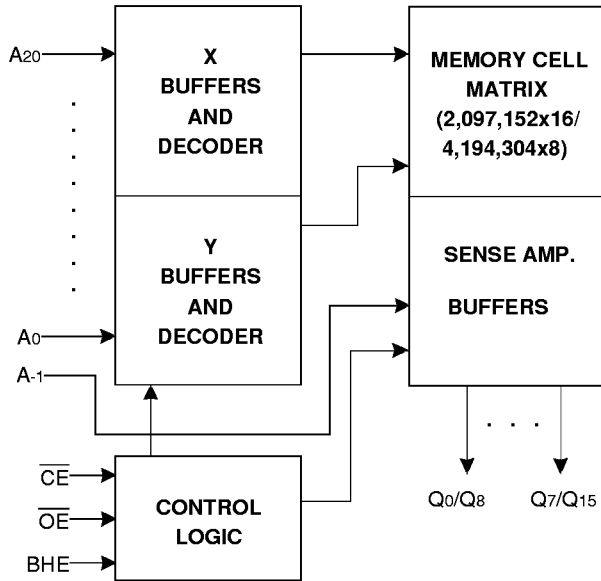

Pin Name	Pin Function
A0 - A20	Address Inputs
Q0 - Q14	Data Outputs
Q15 /A-1	Output 15(Word mode)/ LSB Address(Byte mode)
BHE	Word/Byte selection
$\overline{CE}$	Chip Enable
$\overline{OE}$	Output Enable
Vcc	Power
Vss	Ground
N.C	No Connection

### PRODUCT INFORMATION

Product	Operating Temp Range	Vcc Range (Typical)	Speed (ns)
KM23V32000CT	0°C~70°C	3.3V/3.0V	120/150
KM23V32000CET	-20°C~85°C		

### PIN CONFIGURATION

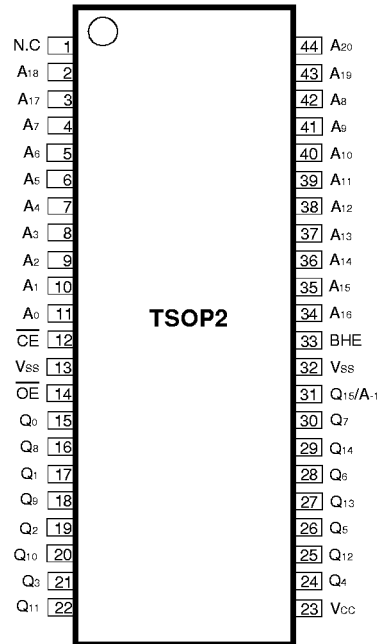

KM23V32000C(E)T

**ABSOLUTE MAXIMUM RATINGS**

Item	Symbol	Rating	Unit	Remark
Voltage on Any Pin Relative to V <sub>SS</sub>	V <sub>IN</sub>	-0.3 to +4.5	V	-
Temperature Under Bias	T <sub>BIAS</sub>	-10 to +85	°C	-
Storage Temperature	T <sub>STG</sub>	-55 to +150	°C	-
Operating Temperature	T <sub>A</sub>	0 to +70	°C	KM23V32000CT
		-20 to +85	°C	KM23V32000CET

**NOTE** : Permanent device damage may occur if "ABSOLUTE MAXIMUM RATINGS" are exceeded. Functional operation should be restricted to the conditions as detailed in the operational sections of this data sheet. Exposure to absolute maximum rating conditions for extended periods may affect device reliability.

**RECOMMENDED OPERATING CONDITIONS**(Voltage reference to V<sub>SS</sub>)

Item	Symbol	Min	Typ	Max	Unit
Supply Voltage	V <sub>CC</sub>	2.7/3.0	3.0/3.3	3.3/3.6	V
Supply Voltage	V <sub>SS</sub>	0	0	0	V

**DC CHARACTERISTICS**

Parameter	Symbol	Test Conditions	Min	Max	Unit	
						Operating Current
			V <sub>CC</sub> =3.0V±0.3V	-	35	mA
Standby Current(TTL)	I <sub>SB1</sub>	$\overline{CE}=V_{IH}$ , all outputs open	-	500	µA	
Standby Current(CMOS)	I <sub>SB2</sub>	$\overline{CE}=V_{CC}$ , all outputs open	-	30	µA	
Input Leakage Current	I <sub>LI</sub>	V <sub>IN</sub> =0 to V <sub>CC</sub>	-	10	µA	
Output Leakage Current	I <sub>LO</sub>	V <sub>OUT</sub> =0 to V <sub>CC</sub>	-	10	µA	
Input High Voltage, All Inputs	V <sub>IH</sub>		2.0	V <sub>CC</sub> +0.3	V	
Input Low Voltage, All Inputs	V <sub>IL</sub>		-0.3	0.6	V	
Output High Voltage Level	V <sub>OH</sub>	I <sub>OH</sub> =-400µA	2.4	-	V	
Output Low Voltage Level	V <sub>OL</sub>	I <sub>OL</sub> =2.1mA	-	0.4	V	

**NOTE** : Minimum DC Voltage(V<sub>IL</sub>) is -0.3V an input pins. During transitions, this level may undershoot to -2.0V for periods<20ns.  
Maximum DC voltage on input pins(V<sub>IH</sub>) is V<sub>CC</sub>+0.3V which, during transitions, may overshoot to V<sub>CC</sub>+2.0V for periods<20ns.

**MODE SELECTION**

$\overline{CE}$	$\overline{OE}$	BHE	Q <sub>15/A-1</sub>	Mode	Data	Power
H	X	X	X	Standby	High-Z	Standby
L	H	X	X	Operating	High-Z	Active
L	L	H	Output	Operating	Q <sub>0</sub> ~Q <sub>15</sub> : Dout	Active
		L	Input	Operating	Q <sub>0</sub> ~Q <sub>7</sub> : Dout Q <sub>8</sub> ~Q <sub>14</sub> : High-Z	Active

**CAPACITANCE**(T<sub>A</sub>=25°C, f=1.0MHz)

Item	Symbol	Test Conditions	Min	Max	Unit
Output Capacitance	C <sub>OUT</sub>	V <sub>OUT</sub> =0V	-	12	pF
Input Capacitance	C <sub>IN</sub>	V <sub>IN</sub> =0V	-	12	pF

**NOTE** : Capacitance is periodically sampled and not 100% tested.

## AC CHARACTERISTICS (V<sub>CC</sub>=3.3V/3.0V±0.3V unless otherwise noted.)

### TEST CONDITIONS

Item	Value
Input Pulse Levels	0.45V to 2.4V
Input Rise and Fall Times	10ns
Input and Output timing Levels	1.5V
Output Loads	1 TTL Gate and C <sub>L</sub> =100pF

### READ CYCLE

Item	Symbol	V <sub>CC</sub> =3.3V±0.3V		V <sub>CC</sub> =3.0V±0.3V		Unit
		Min	Max	Min	Max	
Read Cycle Time	t <sub>RC</sub>	120		150		ns
Chip Enable Access Time	t <sub>ACE</sub>		120		150	ns
Address Access Time	t <sub>AA</sub>		120		150	ns
Output Enable Access Time	t <sub>OE</sub>		60		70	ns
Output or Chip Disable to Output High-Z	t <sub>DF</sub>		20		30	ns
Output Hold from Address Change	t <sub>OH</sub>	0		0		ns

### TIMING DIAGRAM

#### READ

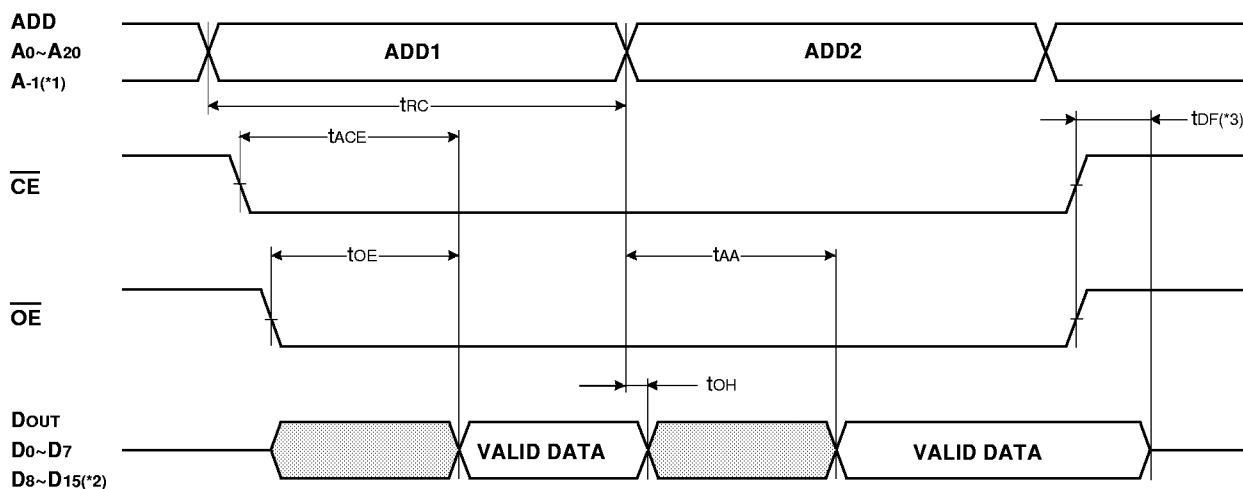

#### NOTES :

\*1. Byte Mode only. A-1 is Least Significant Bit Address. (BHE=V<sub>IL</sub>)

\*2. Word Mode only. (BHE=V<sub>IH</sub>)

\*3. t<sub>DF</sub> is defined as the time at which the outputs achieve the open circuit condition and is not referenced to V<sub>OH</sub> or V<sub>OL</sub> level.

PACKAGE DIMENSIONS (44-TSOP2-400)

(Unit : mm/inch)

