

DM74ALS245A Octal 3-STATE Bus Transceiver

General Description

This advanced low power Schottky device contains 8 pairs of 3-STATE logic elements configured as octal bus transceivers. These circuits are designed for use in memory, micro-processor systems and in asynchronous bidirectional data buses. Two way communication between buses is controlled by the (DIR) input. Data transmits either from the A bus to the B bus or from the B bus to the A bus. Both the driver and receiver outputs can be disabled via the (\bar{G}) enable input which causes outputs to enter the high impedance mode so that the buses are effectively isolated.

Features

- Advanced oxide-isolated, ion-implanted Schottky TTL process
- Non-inverting logic output
- Glitch free bus during power up and down
- 3-STATE outputs independently controlled on A and B buses
- Low output impedance to drive terminated transmission lines to 133Ω
- Switching response specified into $500\Omega/50\text{ pF}$
- Specified to interface with CMOS at $V_{OH} = V_{CC} - 2V$
- PNP inputs to reduce input loading
- Switching specifications guaranteed over full temperature and V_{CC} range

Connection Diagram

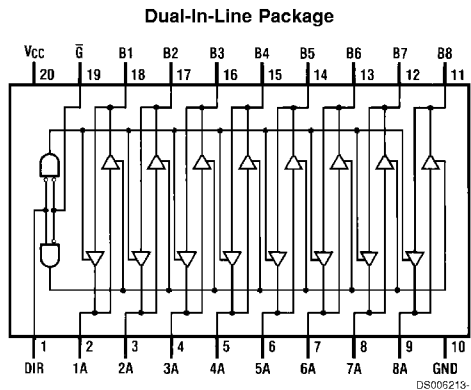

Order Number DM74ALS245MSA, DM74ALS245AWM, DM74ALS245AN or DM74ALS245ASJ
See Package Number M20B, M20D, MQA20 or N20A

Function Table

Control Inputs		Operation
\bar{G}	DIR	
L	L	B Data to A Bus
L	H	A Data to B Bus
H	X	Hi-Z

H = High Logic Level
L = Low Logic Level
X = Either High or Low Logic Level

Absolute Maximum Ratings (Note 1)

Supply Voltage	7V	DM74ALS	0°C to +70°C
Input Voltage		Storage Temperature Range	-65°C to +150°C
Control Inputs	7V	Typical θ_{JA}	
I/O Ports	5.5V	N Package	53.0°C/W
Operating Free Air Temperature Range		M Package	72.0°C/W

Recommended Operating Conditions

Symbol	Parameter	DM74ALS245A			Units
		Min	Typ	Max	
V_{CC}	Supply Voltage	4.5	5	5.5	V
V_{IH}	High Level Input Voltage	2			V
V_{IL}	Low Level Input Voltage			0.8	V
I_{OH}	High Level Output Current			-15	mA
I_{OL}	Low Level Output Current			24	mA
T_A	Operating Free Air Temperature	0		70	°C

Note 1: The "Absolute Maximum Ratings" are those values beyond which the safety of the device cannot be guaranteed. The device should not be operated at these limits. The parametric values defined in the "Electrical Characteristics" table are not guaranteed at the absolute maximum ratings. The "Recommended Operating Conditions" table will define the conditions for actual device operation.

Electrical Characteristics

over recommended operating free air temperature range. All typical values are measured at $V_{CC} = 5V$, $T_A = 25^\circ C$.

Symbol	Parameter	Conditions	Min	Typ	Max	Units
V_{IK}	Input Clamp Voltage	$V_{CC} = 4.5V$, $I_{IN} = -18 mA$			-1.5	V
V_{OH}	High Level Output Voltage	$V_{CC} = 4.5V$, $I_{OH} = -3 mA$	2.4	3.2		V
		$V_{CC} = 4.5V$, $I_{OH} = Max$	2	2.3		V
		$I_{OH} = -0.4 mA$, $V_{CC} = 4.5V$ to $5.5V$	$V_{CC} - 2$			V
V_{OL}	Low Level Output Voltage	$V_{CC} = 4.5V$, $I_{OL} = 24 mA$		0.35	0.5	V
I_I	Input Current at Max Input Voltage	$V_{CC} = 5.5V$, $V_{IN} = 7V$			0.1	mA
		$V_{CC} = 5.5V$, $V_{IN} = 5.5V$			0.1	
I_{IH}	High Level Input Current	$V_{CC} = 5.5V$, $V_{IN} = 2.7V$			20	μA
I_{IL}	Low Level Input Current	$V_{CC} = 5.5V$, $V_{IN} = 0.4V$			-0.1	mA
I_O	Output Drive Current	$V_{CC} = 5.5V$, $V_{OUT} = 2.25V$	-30		-112	mA
I_{CC}	Supply Current	$V_{CC} = 5.5V$, Outputs High		30	45	mA
		$V_{CC} = 5.5V$, Outputs Low		36	55	mA
		$V_{CC} = 5.5V$, 3-STATE		38	58	mA

Switching Characteristics

over recommended operating free air temperature range (Notes 2, 3)

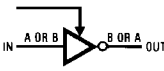
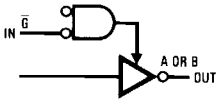
Symbol	Parameter	Circuit Configuration	DM74ALS245A		Units
			Min	Max	
t_{PLH}	Propagation Delay Time Low-to-High Level Output		3	10	ns
t_{PHL}	Propagation Delay Time High-to-Low Level Output		3	10	ns
t_{PZL}	Output Enable Time to Low Level		5	20	ns
t_{PZH}	Output Enable Time to High Level		5	20	ns
t_{PLZ}	Output Disable Time from Low Level		4	15	ns
t_{PHZ}	Output Disable Time from High Level		2	10	ns

Note 2: See Section 1 for test waveforms and output load.

Note 3: Switching characteristic conditions are $V_{CC} = 4.5V$ to $5.5V$, $R_L = 500\Omega$, $C_L = 50$ pF.

Physical Dimensions inches (millimeters) unless otherwise noted

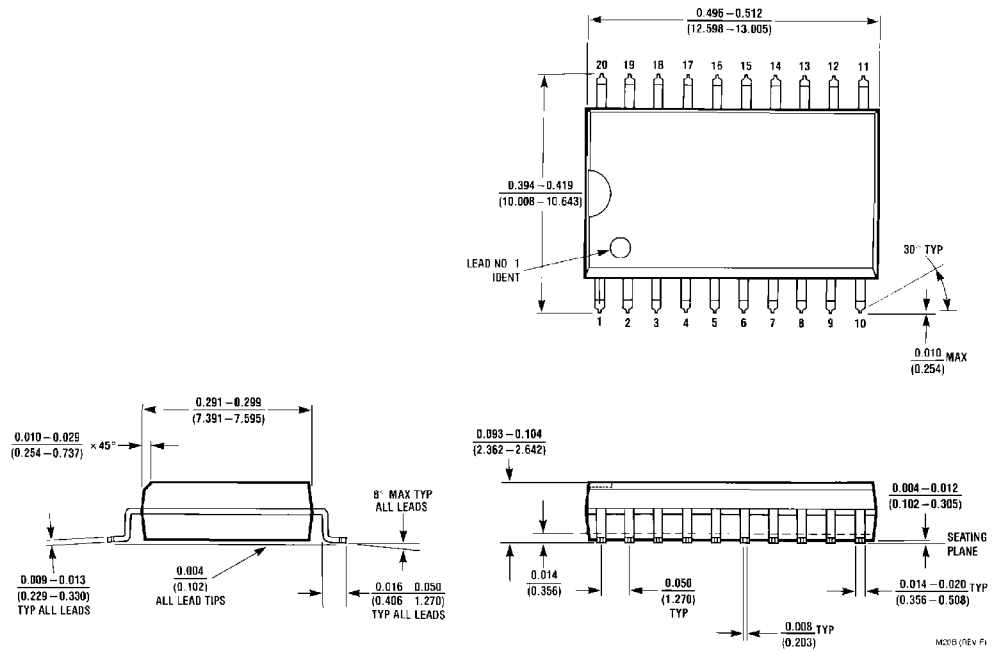

20-Lead (0.300" Wide) Small Outline Package (M)
Order Number DM74ALS245MSA or DM74ALS245AWM
Package Number M20B

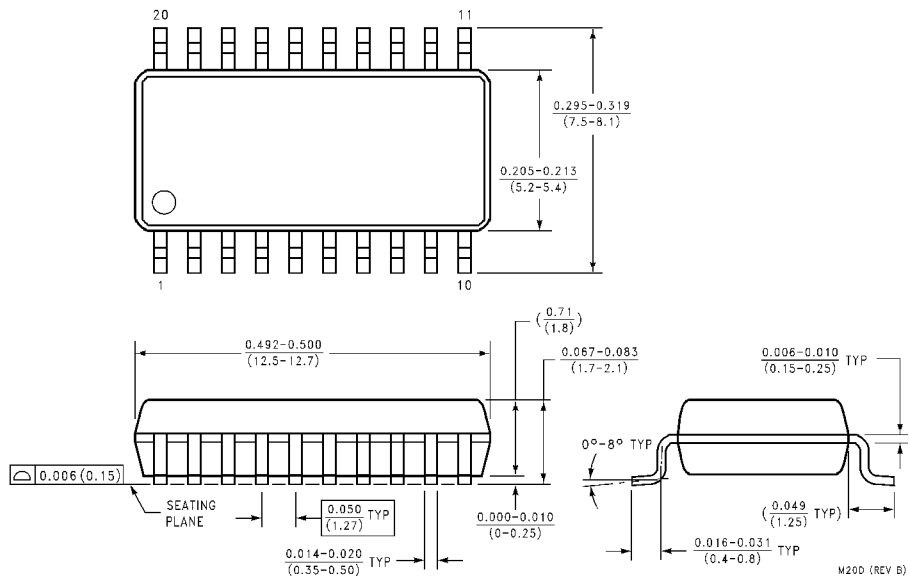

20-Lead Small Output Package-EIAJ (SJ)
Order Number DM74ALS245ASJ
Package Number M20D

Physical Dimensions inches (millimeters) unless otherwise noted (Continued)

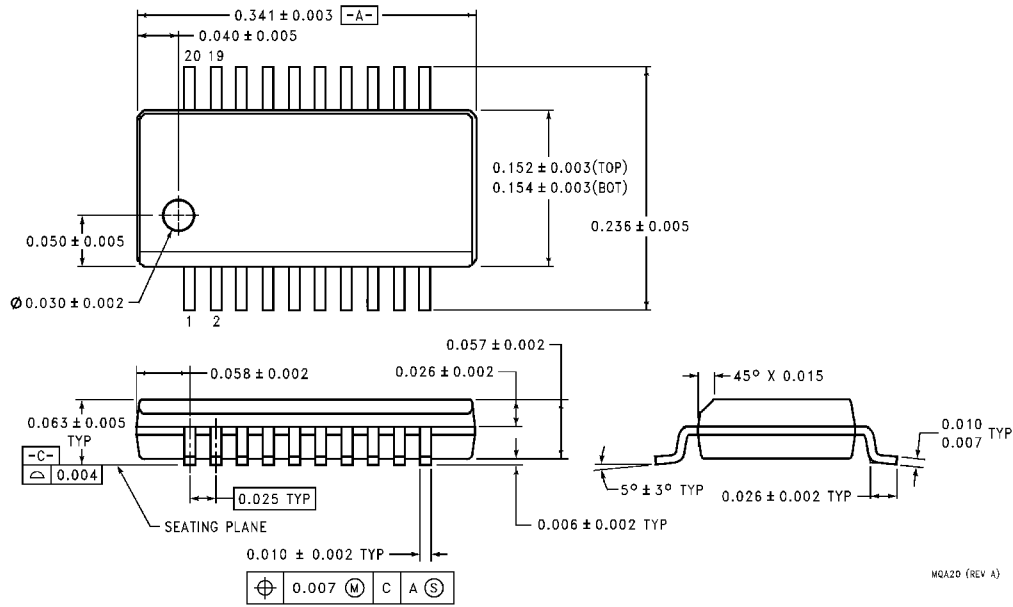

20-Lead (0.150" Wide) Shrink Small Outline Package, JEDEC
Package Number MQA20

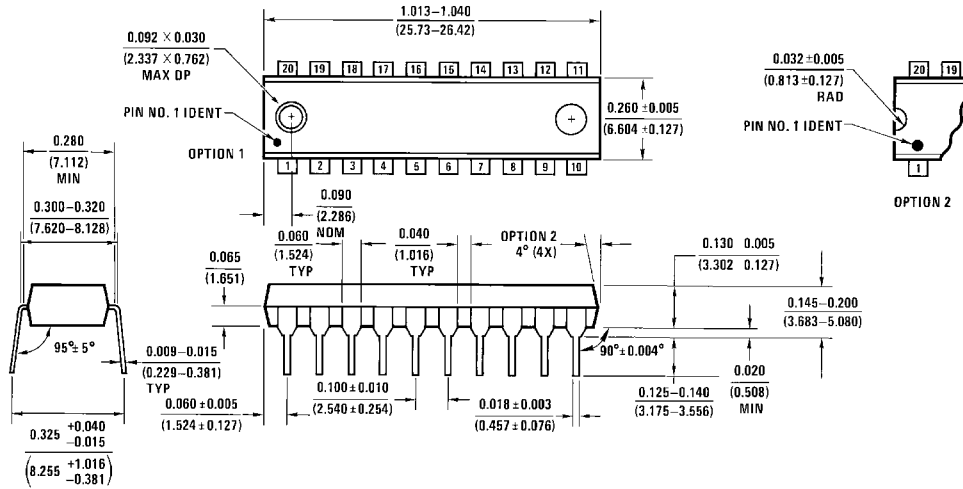

Molded Dual-In-Line Package (N)
Order Number DM74ALS245AN
Package Number N20A

LIFE SUPPORT POLICY

FAIRCHILD'S PRODUCTS ARE NOT AUTHORIZED FOR USE AS CRITICAL COMPONENTS IN LIFE SUPPORT DEVICES OR SYSTEMS WITHOUT THE EXPRESS WRITTEN APPROVAL OF THE PRESIDENT OF FAIRCHILD SEMICONDUCTOR CORPORATION. As used herein:

1. Life support devices or systems are devices or systems which, (a) are intended for surgical implant into the body, or (b) support or sustain life, and (c) whose failure to perform when properly used in accordance with instructions for use provided in the labeling, can be reasonably expected to result in a significant injury to the user.
2. A critical component in any component of a life support device or system whose failure to perform can be reasonably expected to cause the failure of the life support device or system, or to affect its safety or effectiveness.

Fairchild Semiconductor Corporation
Americas
Customer Response Center
Tel: 1-888-522-5372

www.fairchildsemi.com

Fairchild Semiconductor Europe
Fax: +49 (0) 1 80-530 85 86
Email: europa.support@nsc.com
Deutsch Tel: +49 (0) 8 141-35-0
English Tel: +44 (0) 1 793-85-68-56
Italy Tel: +39 (0) 2 57 5631

Fairchild Semiconductor Hong Kong Ltd.
13th Floor, Straight Block,
Ocean Centre, 5 Canton Rd.
Tsimshatsui, Kowloon
Hong Kong
Tel: +852 2737-7200
Fax: +852 2314-0061

National Semiconductor Japan Ltd.
Tel: 81-3-5620-6175
Fax: 81-3-5620-6179