

2.5V or 3.3V I/O
143/133/117/100

128K x 36 NBT

NO BUS TURNAROUND
PIPELINE

FEATURES

- 3.3V +10%/ -5% Core power supply, 2.5V or 3.3V I/O supply
- High frequency operation and 100% bus utilization
- Fast Clock to Q: 4, 4.2, 4.5, and 5ns
- Advanced control logic for minimum control signal interface
- FT mode pin for either flow-through or pipeline operation
- LBO mode pin for linear or interleave (Pentium™ and X86) burst mode
- Byte write (BWE) operation
- 3 chip enable signals for easy depth expansion
- Clamp diodes to VSSQ at all inputs and outputs
- Common datas inputs and data outputs
- Clock Control, registered, address, data, and control
- Internal Self-Timed WRITE cycle
- Automatic power-down for portable applications
- JEDEC standard 100-lead package: T:QFP

FUNCTIONAL DESCRIPTION

The GS840NBT36PT is a No Bus Turnaround 128kX36 high performance synchronous SRAM with 2 bit burst counter. It is designed to provide L2 Cache for Pentium™ and other high performance CPU. Addresses, data I/Os, chip enables (CE1, CE2, CE3), address control inputs (ADV/LD), synchronous clock enable (CKE), read/write (R/W) and write control inputs (BWT, BW2, BW3, BW4) are synchronous and are controlled by a positive-edge-triggered clock (CLK).

The output enable (OE) and power down control (ZZ) are asynchronous inputs. The OE can be tied LOW for control signal minimization and the ZZ may be tied LOW if unused. The burst sequence is either interleave order (Pentium™

Output registers are provided and are controlled by FT mode pin. With FT mode pin, output registers can be programmed in either pipeline mode for very high frequency operation (143MHz) or flow-thru mode for reduced latency.

Byte write operations can be obtained through the combination of four individual byte write signals: BW1-4.

The burst advance (ADV/LD) input initiates all READ, WRITE, and DESELECT cycles, and the ADV/LD pin can internally generate subsequent burst addresses.

To simplify WRITE cycles, address and write control are registered on-chip, allowing self-timed WRITE cycles. Individual byte enables allow individual bytes to be written. Conditioned by R/W having initiated a WRITE cycle, BW1 controls DQ1 pins; BW2 controls DQ2 pins; BW3 controls DQ3 pins; and BW4 controls DQ4 pins.

Low power state (standby mode) can be obtained either through the assertion of ZZ signal or simply stop the clock (CLK). In standby mode, memory data is still retained.

The GS840NBT36PT operates from a 3.3V power supply and all inputs and outputs are 3.3V or 2.5V LVTTTL compatible. Separate output power (VDDQ) and ground (VSSQ) pins are employed to de-couple output noise from internal circuit.

The GS840NBT36PT is implemented with GSI's 0.3 micron high-performance CMOS technology and is available in JEDEC standard 100-lead TQFP (T version).

*** Pentium is a trademark of Intel Corp. ***



Pin configuration

Top view

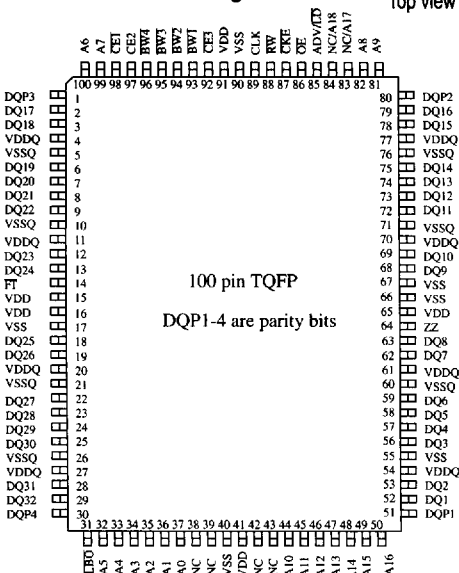

100 pin TQFP
DQP1-4 are parity bits

PIN LOCATION	SYMBOL	DESCRIPTION
32, 33, 34, 35, 36, 37, 44, 45, 46, 47, 48, 49, 50, 81, 82, 99, 100	A0-16	Address Inputs. These inputs are registered and must meet setup and hold times.
87, 89	CLK	Clock Input
88	RW	Read/Write Enable
93, 94, 95, 96	BW1, BW2, BW3, BW4	Byte Write. BW1 for DQ1-8; BW2 for DQ9-16; BW3 for DQ17-24; BW4 for DQ25-32
92, 97, 98	CE1, CE2, CE3	Chip Enable
86	OE	Output Enable
85	ADV/LD	Address Advance/Load
2, 3, 6, 7, 8, 9, 12, 13, 18, 19, 22, 23, 24, 25, 28, 29, 52, 53, 56, 57, 58, 59, 62, 63, 68, 69, 72, 73, 74, 75, 78, 79	DQ1-32	Data I/O
1, 30, 51, 80	DQP1-4	Data Parity I/O
64	ZZ	Power down control
14	FT	Flow-Through mode
31	LBO	Linear Burst mode
15, 16, 41, 65, 91	VDD	3.3V Power Supply
17, 40, 55, 66, 67, 90	VSS	Ground
4, 11, 20, 27, 54, 61, 70, 77	VDDQ	3.3V Output Power Supply
5, 10, 21, 26, 60, 71, 76	VSSQ	Output Ground
38, 39, 42, 43, 64, 83, 84	NC	No Connect

2.5V or 3.3V I/O
143/133/117/100

128K x 36 NBT

NO BUS TURNAROUND
PIPELINE

Functional Block Diagram

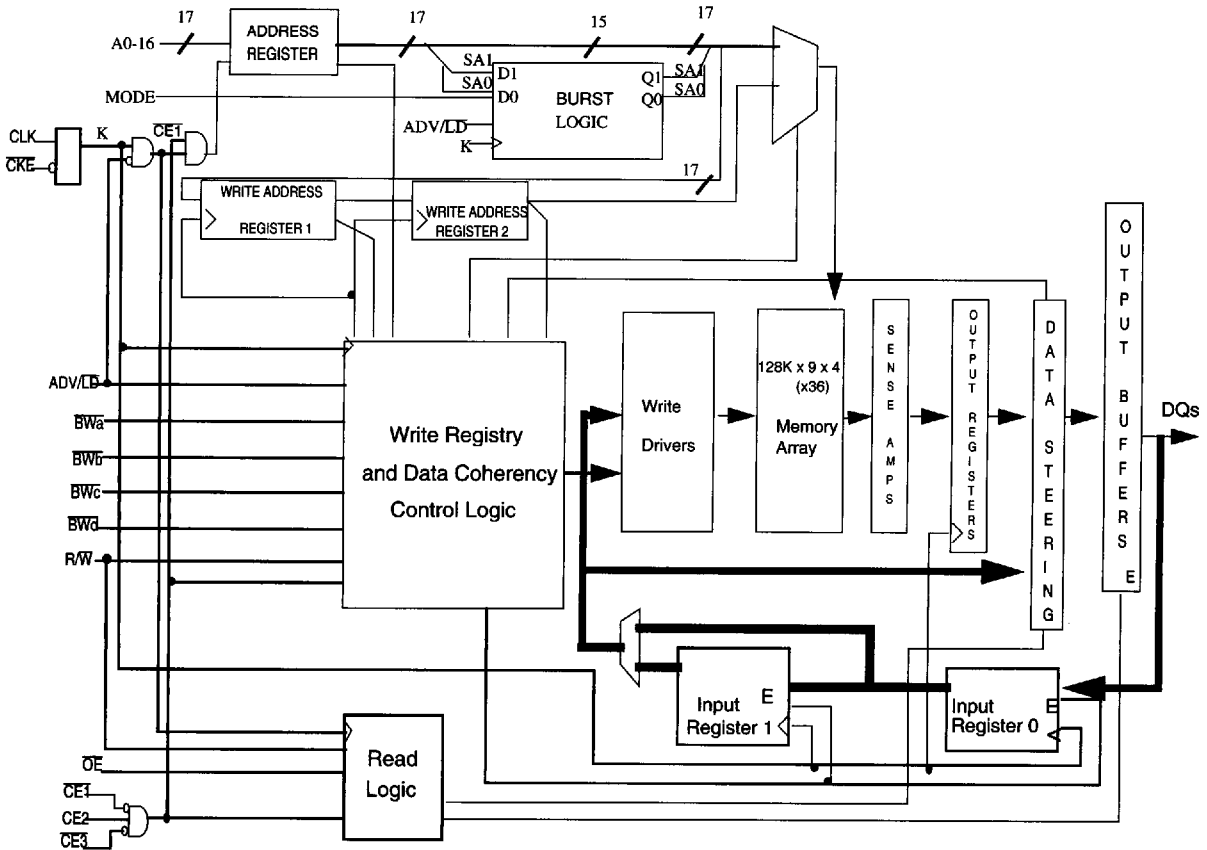

MODE PIN FUNCTION

LBO	Function
L	Linear Burst
H or NC	Interleaved Burst

FT	Function
L	Flow-Thru
H or NC	Pipeline

POWER DOWN CONTROL

ZZ	Function
L or NC	Active
H	Standby IDD=ISB

4

Note: There are pull up devices on LBO and FT pins and pull down device on ZZ pin, so those input pins can be unconnected and the chip will operate in the default states as specified in the above tables.

LINEAR BURST SEQUENCE

	A[1:0]	A[1:0]	A[1:0]	A[1:0]
1st address	00	01	10	11
2nd address	01	10	11	00
3rd address	10	11	00	01
4th address	11	00	01	10

The burst wrap around to initial state upon completion.

INTERLEAVED BURST SEQUENCE

	A[1:0]	A[1:0]	A[1:0]	A[1:0]
1st address	00	01	10	11
2nd address	01	00	11	10
3rd address	10	11	00	01
4th address	11	10	01	00

The burst wrap around to initial state upon completion.

BYTE WRITE FUNCTION

Function	SGW	BWE	BWI	BW2	BW3	BW4
Read	H	H	X	X	X	X
Read	H	L	H	H	H	H
Write all bytes	L	X	X	X	X	X
Write all bytes	H	L	L	L	L	L
Write byte 1	H	L	L	H	H	H
Write byte 2	H	L	H	L	H	H
Write byte 3	H	L	H	H	L	H
Write byte 4	H	L	H	H	H	L

Note: H=logic high, L=logic low, NC= no connect

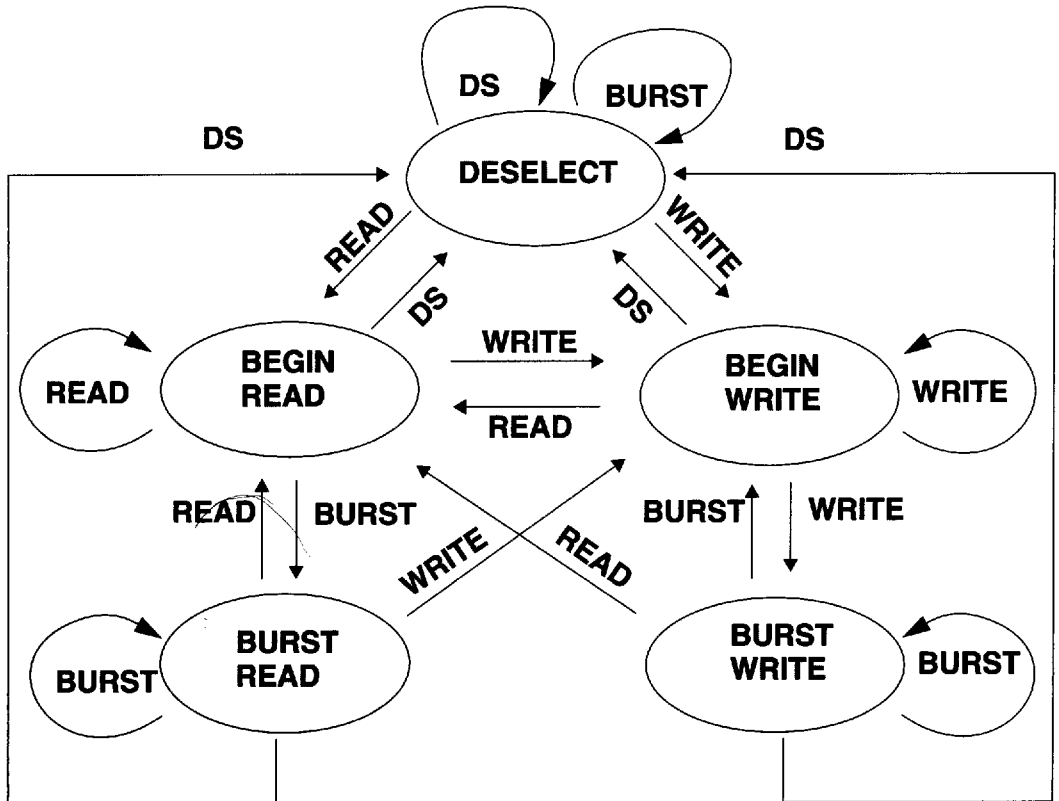

Table 1: KEY

COMMAND	ACTION
DS	Deselect
READ	New READ
WRITE	New WRITE
BURST	BURST READ, BURST WRITE, or CONTINUE DESELECT

2.5V or 3.3V I/O
 143/133/117/100

128K x 36 NBT

 NO BUS TURNAROUND
 PIPELINE

SYNCHRONOUS TRUTH TABLE

OPERATION	ADDRESS USED	CE1	CE2	CE3	ZZ	ADV/ LD	R/W	BWx	OE	CKE	CLK	DQ	NOTES
Deselect Cycle, Power Down	NONE	H	X	X	L	L	X	X	X	L	L-H	High-Z	
Deselect Cycle, Power Down	NONE	X	X	H	L	L	X	X	X	L	L-H	High-Z	
Deselect Cycle, Power Down	NONE	X	L	X	L	L	X	X	X	L	L-H	High-Z	
Deselect Cycle, Continue	NONE	X	X	X	L	H	X	X	X	L	L-H	High-Z	1
READ Cycle, Begin Burst	EXTERNAL	L	H	L	L	L	H	X	L	L	L-H	Q	
READ Cycle, Continue Burst	NEXT	X	X	X	L	H	X	X	L	L	L-H	Q	1,10
NOP/READ, Begin Burst	EXTERNAL	L	H	L	L	L	H	X	H	L	L-H	High-Z	2
Dummy READ, Continue Burst	NEXT	X	X	X	L	H	X	X	H	L	L-H	High-Z	1,2,10
WRITE Cycle, Begin Burst	EXTERNAL	L	H	L	L	L	L	L	X	L	L-H	D	3
WRITE Cycle, Continue Burst	NEXT	X	X	X	L	H	X	L	X	L	L-H	D	1,3,10
NOP/WRITE Abort, Begin Burst	NONE	L	H	L	L	L	L	H	X	L	L-H	High-Z	2,3
WRITE Abort, Continue Burst	NEXT	X	X	X	L	H	X	H	X	L	L-H	High-Z	1,2,3,10
Clock Edge Ignore, Stall	CURRENT	X	X	X	L	X	X	X	X	H	L-H	-	4
SNOOZE MODE	NONE	X	X	X	H	X	X	X	X	X	X	High-Z	

Note:

- Continue BURST cycles, whether READ or WRITE, use the same control inputs. A DESELECT continue cycle can only be entered into if a DESELECT cycle is executed first.
- Dummy READ and WRITE abort can be considered NOP's because the SRAM performs no operation. A WRITE abort occurs when a WRITE command is given; however, no operation is performed.
- OE can be wired LOW to minimize the number of control signals provided to the SRAM. Output drivers will automatically turn off during WRITE cycles.
- If an IGNORE CLOCK EDGE instruction occurs during a READ cycle, the DQ bus will remain active (Low Z). If IGNORE CLOCK EDGE occurs during a WRITE cycle, the bus will remain in High Z. WRITE operations will not occur during an IGNORE CLOCK EDGE cycle.
- X = "Don't Care." H means "Logic High." L means "Logic Low." BWx = High means "All Byte/Write signals are high." BWx = Low means "One or more Byte/Write signals are Low."
- All inputs, except OE and ZZ must meet setup and hold times of rising clock edge.
- Wait states can be inserted by setting CKE high.
- This device contains circuitry that ensures all outputs are in High Z during power-up.
- A 2-bit burst counter is incorporated.
- The address counter is incremented for all BURST continue cycles.

2.5V or 3.3V I/O
143/133/117/100

128K x 36 NBT

NO BUS TURNAROUND
PIPELINE

PARTIAL TRUTH TABLE FOR READ/WRITE OPERATION

FUNCTION	R/W	BW1	BW2	BW3	BW4
READ	H	X	X	X	X
WRITE BYTE "A"	L	L	H	H	H
WRITE BYTE "B"	L	H	L	H	H
WRITE BYTE "C"	L	H	H	L	H
WRITE Byte "D"	L	H	H	H	L
WRITE ALL BYTES	L	L	L	L	L
WRITE ABORT/NOP	L	H	H	H	H

ABSOLUTE MAXIMUM RATINGS (Voltage reference to VSS=0V)

Symbol	Description	Commercial	Industrial	Unit
VDD	Supply Voltage	-0.5 to 4.6	-0.5 to 4.6	V
VDDQ	Output Supply Voltage	-0.5 to VDD	-0.5 to VDD	V
VCLK	CLK Input Voltage	-0.5 to 6	-0.5 to 6	V
VIN	Input Voltage	-0.5 to VDD+0.5 (≤ 4.6 V max.)	-0.5 to VDD+0.5 (≤ 4.6 V max.)	V
VOUT	Output Voltage	-0.5 to VDD+0.5 (≤ 4.6 V max.)	-0.5 to VDD+0.5 (≤ 4.6 V max.)	V
IOUT	Output Current per I/O	+/- 20	+/- 20	mA
PD	Power Dissipation	1.5	1.6	W
Topr	Operating Temperature	0 to 70	-45 to +85	°C
Tstg	Storage Temperature	-55 to 150	-65 to 150	°C

Note: A permanent damage may occur if Absolute Maximum Rating are exceeded. Functional operation should be restricted to the Recommended Operation Conditions. Exposure to higher than recommended voltages for an extended period of time could effect the performance and reliability of this component.

RECOMMENDED OPERATING CONDITIONS (Voltage reference to VSS=0V)
(VDD=3.135V to 3.6V, Ta=-40 to +85°C)

Parameter	Symbol	Min.	Typ.	Max.	Unit
Supply Voltage	VDD	3.135	3.3	3.6	V
I/O Supply Voltage	VDDQ	2.375	2.5	VDD	V
Input High Voltage	VIH	1.7	---	VDD+0.3	V
Input Low Voltage	VIL	-0.3	---	0.8	V

Note: Input overshoot voltage should be less than VDD+2V and not exceed 5ns.
Input undershoot voltage should be higher than -2V and not exceed 5ns.

4

CAPACITANCE (Ta=25°C, f=1MHz, VDD=3.3V)

Parameter	Symbol	Test conditions	Typ.	Max.	Unit
Control Input Capacitance	C _i	VDD = 3.3V	3	4	pF
Input/Output Capacitance	C _O	T _A = 25°C	4	5	pF
Address Capacitance	C _A	f = 1 MHz	3	3.5	pF

Note: This parameter is sample tested.

2.5V or 3.3V I/O
143/133/117/100

128K x 36 NBT

NO BUS TURNAROUND
PIPELINE

PACKAGE THERMAL CHARACTERISTICS

Rating	Layer Board	Symbol	TQFP max	Unit	Notes
Junction to Ambient	four	$R\theta_{JA}$	28	$^{\circ}\text{C}/\text{W}$	1,2
Junction to Case	four	$R\theta_{JC}$	4	$^{\circ}\text{C}/\text{W}$	3

NOTES:

1. Junction temperature is a function of SRAM power dissipation, package thermal resistance, mounting board temperature, ambient temperature air flow, board density, and PCB thermal resistance.
2. SCMI G-38-87
3. Average thermal resistance between die and top surface, MIL SPEC-883, Method 1012.1.

AC TEST CONDITIONS

(VDD=3.135V to 3.6V, Ta=0 to 70C)

Parameter	Conditions
Input high level	VIH=2.4V
Input low level	VIL=0.4V
Input slew rate	tr=1V/ns
Output rise and fall times (max)	1.8ns
Input reference level	1.5V
Output reference level	1.5V
Output load	Fig. 1 & 2

- Note**
1. Include scope and jig capacitance.
 2. Test conditions as specified with output loading as shown in Fig. 1 unless otherwise noted
 3. Output load 2 for t_{LZ} , t_{HZ} , t_{OLZ} and t_{OHZ} .
 4. Device is deselected as defined by the Truth Table.

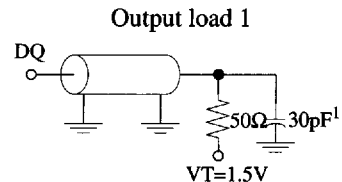

Fig. 1

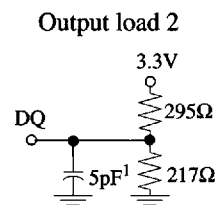

Fig. 2

2.5V or 3.3V I/O
143/133/117/100

128K x 36 NBT

NO BUS TURNAROUND
PIPELINE

DC Characteristics and Supply Currents (Voltage reference to VSS=0V)

(VDD=3.135V to 3.6V, Ta=0 to 70°C)

(T_A= -40 to + 85°C for Industrial Temperature Offering)

Parameter	Symbol	Test Conditions	-143MHz		-133MHz		-117MHz		-100MHz	
			Min	Max	Min	Max	Min	Max	Min	Max
Input Leakage Current (except ZZ, FT, LBO pins)	I _{IL}	V _{IN} = 0 to V _{DD}	-1uA	1uA	-1uA	1uA	-1uA	1uA	-1uA	1uA
ZZ Input Current	I _{INZZ}	V _{DD} ≥ V _{IN} ≥ V _{IH} 0V ≤ V _{IN} ≤ V _{IH}	-1uA -1uA	1uA 300uA	-1uA -1uA	1uA 300uA	-1uA -1uA	1uA 300uA	-1uA -1uA	1uA 300uA
Mode Input Current (FT & LBO pins)	I _{INM}	V _{DD} ≥ V _{IN} ≥ V _{IH} 0V ≤ V _{IN} ≤ V _{IH}	-300uA -1uA	1uA 1uA	-300uA -1uA	1uA 1uA	-300uA -1uA	1uA 1uA	-300uA -1uA	1uA 1uA
Output Leakage Current	I _{OL}	Output Disable, V _{OUT} = 0 to V _{DD}	-1uA	1uA	-1uA	1uA	-1uA	1uA	-1uA	1uA
Output High Voltage	V _{OH}	I _{OH} = - 8mA, VDDQ=2.5V	2.4V		2.4V		2.4V		2.4V	
Output Low Voltage	V _{OL}	I _{OL} = + 8mA, VDDQ=3.3V		0.4V		0.4V		0.4V		0.4V

4

Parameter	Symbol	Test Conditions	-143MHz		-133MHz		-117MHz		-100MHz	
			0 to 70C	-40 to +85C	0 to 70C	-40 to +85C	0 to 70C	-40 to +85C	0 to 70C	-40 to +85C
Operating Supply Current (V _{DD} = max, E = V _{IH})	I _{DD}	Device Selected; All other inputs ≥ V _{IH} or ≤ V _{IL} Output open	330mA	N/A	290mA	300mA	240mA	250mA	220mA	230mA
Power Supply Current: Idle	I _{DD1}	Device Selected; VDD = Max: CKE ≥ V _{IH} All inputs ≤ VSS + 0.2 or ≥ VDD - 0.2; Cycle Time ≥ t _{KC} (min)	15mA	N/A	12mA	15mA	10mA	15mA	8mA	15mA
Standby Current	I _{SB}	ZZ ≥ V _{DD} - 0.2V	10mA	N/A	10mA	15mA	10mA	15mA	10mA	15mA
Deselect Supply Current Clock Running	I _{DD}	Device Selected; All other inputs ≥ V _{IH} or ≤ V _{IL}	70mA	N/A	60mA	70mA	60mA	70mA	55mA	65mA

2.5V or 3.3V I/O
143/133/117/100

128K x 36 NBT

NO BUS TURNAROUND
PIPELINE

AC ELECTRICAL CHARACTERISTICS

(VDD=3.135V to 3.6V, Ta=0 to 70°C)

Parameter	Symbol	-143MHz		-133MHz		-117MHz		-100MHz		Unit	Notes
		Min	Max	Min	Max	Min	Max	Min	Max		
Clock Cycle Time	t _{KC}	7		7.5		8.5		10		ns	
Clock HIGH Time	t _{KH}	2	---	2.2	---	3.4	---	3.5	---	ns	
Clock LOW Time	t _{KL}	2	---	2.2	---	3.4	---	3.5	---	ns	
Clock to Output Valid	t _{KQ}		4		4.2		4.5		5	ns	1
Clock to Output Invalid	t _{KQX}	1.5		1.5		1.5		1.5		ns	1
Clock High to Output in Low-Z	t _{KQLZ}	1.5	---	1.5	---	1.5	---	1.5	---	ns	1,2,3
Clock to Output in High-Z	t _{KQHZ}	1.5	4	1.5	4.2	1.5	4.5	1.5	5	ns	1,2,3
Output Enable to Output in Low-Z	t _{OELZ}	0		0		0		0		ns	1,2,3
Output to Output in High-Z	t _{OEHZ}		4		4.2		4.5		5	ns	1,2,3
Setup time	t _S	1.7	---	1.7	---	1.7	---	2	---	ns	1,4
Hold time	t _H	0.5	---	0.5	---	0.5	---	0.5	---	ns	1,4
ZZ setup time	t _{ZZS} ³	5	---	5	---	5	---	5	---	ns	1,3
ZZ hold time	t _{ZZH} ³	1	---	1	---	1	---	1	---	ns	1,3
ZZ recovery	t _{ZZR}	20	---	20	---	20	---	20	---	ns	1,3

Note:

1. Tested per AC Test Load, Figure 2 (page 8)
2. This parameter sampled. Measured at +/- 200mV from steady state.
3. ZZ is an asynchronous signal; however, in order to be recognized on any given clock cycle, the signal must meet specified setup and hold time.
4. Because this is a synchronous device, all addresses must meet the setup and hold times specified for the rising edge of CLK when ADV/LD is low and chip is enabled. All other synchronous inputs must meet the setup and hold times for all rising edges of CLK when chip is enabled.

Read/Write Cycle Timing

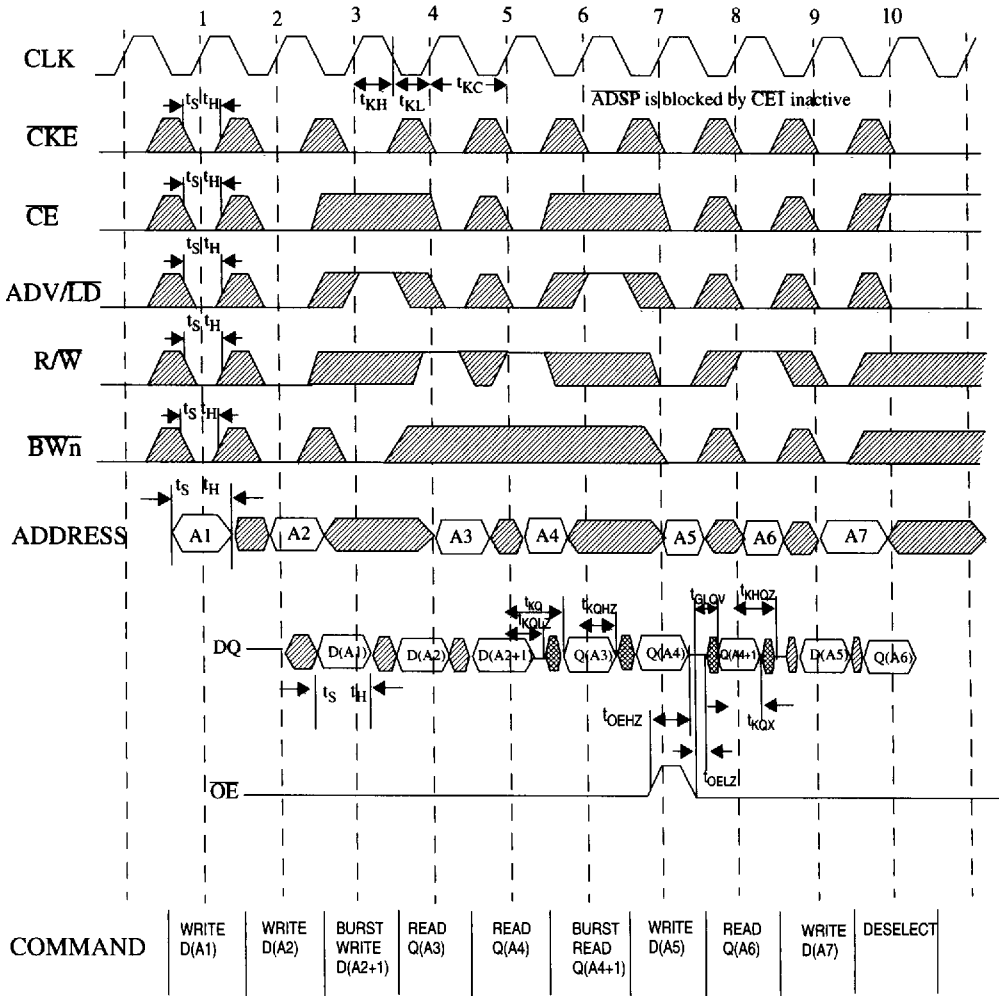

 DON'T CARE
  UNDEFINED

4

2.5V or 3.3V I/O
143/133/117/100

128K x 36 NBT

NO BUS TURNAROUND
PIPELINE

NOP, STALL AND DESELECT Timing

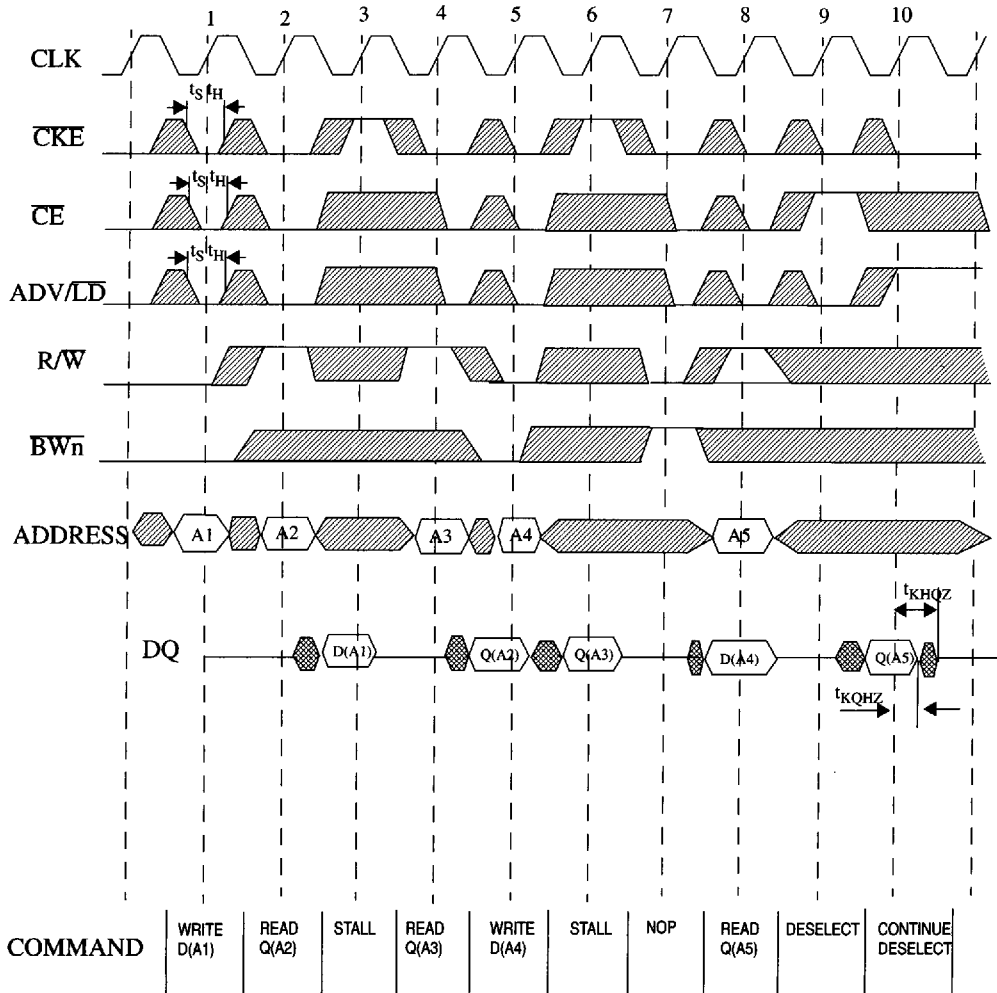

▨ DON'T CARE ▩ UNDEFINED

ZZ Timing

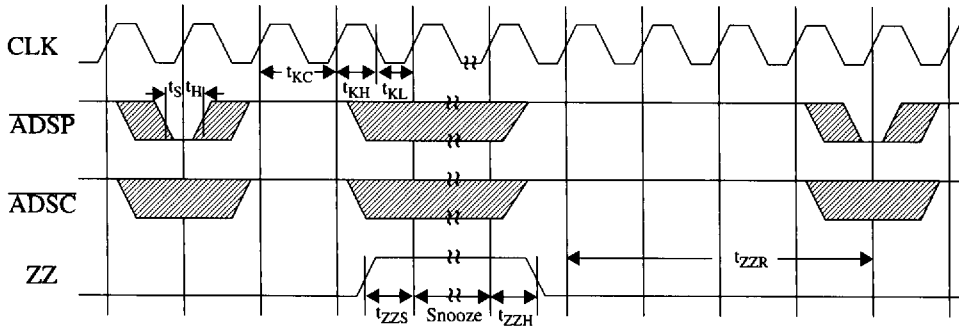

4

2.5V or 3.3V I/O
143/133/117/100

128K x 36 NBT

NO BUS TURNAROUND
PIPELINE

PACKAGE DIMENSIONS
TQFP

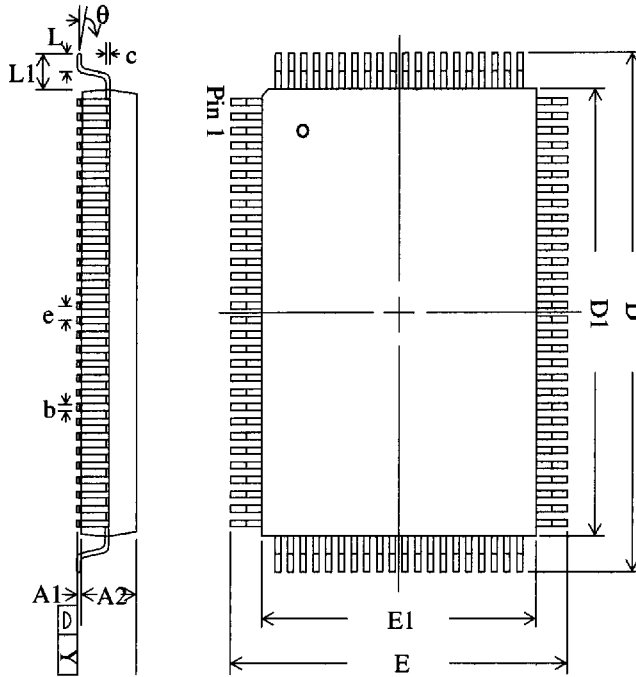

Symbol	Description	Min.	Nom.	Max
A1	Standoff	0.05	0.10	0.15
A2	Body Thickness	1.35	1.40	1.45
b	Lead Width	0.20	0.30	0.40
c	Lead Thickness	0.09		0.20
D	Terminal Dimension	21.9	22.0	20.1
D1	Package Body	19.9	20.0	20.1
E	Terminal Dimension	15.9	16.0	16.1
E1	Package Body	13.9	14.0	14.1
e	Lead Pitch		0.65	
L	Foot Length	0.45	0.60	0.75
L1	Lead Length		1.00	
Y	Coplanarity			0.10
θ	Lead Angle	0°		7°

Note:

1. All dimensions are in millimeters (mm).
2. Package width and length do not include mold protrusion.

32 Pin SOI, 400 mil

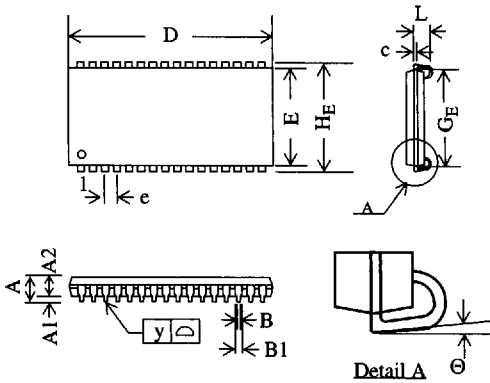

Symbol	Dimension in inch			Dimension in mm		
	min	nom	max	min	nom	max
A	-	-	0.146	-	-	3.70
A1	0.026	-	-	0.66	-	-
A2	0.105	0.110	0.115	2.67	2.80	2.92
B	0.013	0.017	0.021	0.33	0.43	0.53
B1	0.024	0.028	0.032	0.61	0.71	0.81
c	0.006	0.008	0.012	0.15	0.20	0.30
D	0.820	0.824	0.829	20.83	20.93	21.06
E	0.395	0.400	0.405	10.04	10.16	10.28
e	-	0.05	-	-	1.27	-
HE	0.430	0.435	0.440	10.93	11.05	11.17
GE	0.354	0.366	0.378	9.00	9.30	9.60
L	0.082	-	-	2.08	-	-
y	-	-	0.004	-	-	0.10
Θ	0°	-	10°	0°	-	10°

Note:

1. Dimension D & E do not include interlead flash
2. Dimension B1 does not include dambar protrusion / intrusion
3. Controlling dimension: inches

32 Pin SOI, 300 mil

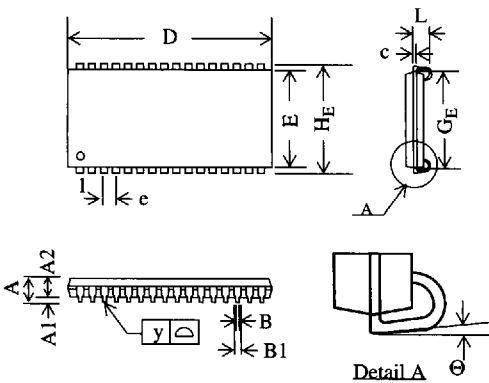

Symbol	Dimension in inch			Dimension in mm		
	min	nom	max	min	nom	max
A	0.125	-	0.148	3.175	-	3.76
A1	0.026	-	-	0.66	-	-
A2	0.095	0.100	0.105	2.41	2.54	2.67
B	0.013	0.017	0.021	0.33	0.43	0.53
B1	0.024	0.028	0.032	0.61	0.71	0.81
c	0.006	0.008	0.012	0.15	0.20	0.30
D	0.820	0.825	0.830	20.82	20.95	21.08
E	0.295	0.300	0.305	7.49	7.62	7.75
e	-	0.05	-	-	1.27	-
HE	0.330	0.335	0.340	8.38	8.51	8.64
GE	0.255	0.267	0.275	6.48	6.78	6.985
L	0.082	-	-	2.08	-	-
y	-	-	0.004	-	-	0.10
Θ	0°	-	10°	0°	-	10°

Note:

1. Dimension D & E do not include interlead flash
2. Dimension B1 does not include dambar protrusion / intrusion
3. Controlling dimension: inches

44 Pin TSOP type II, 400mil

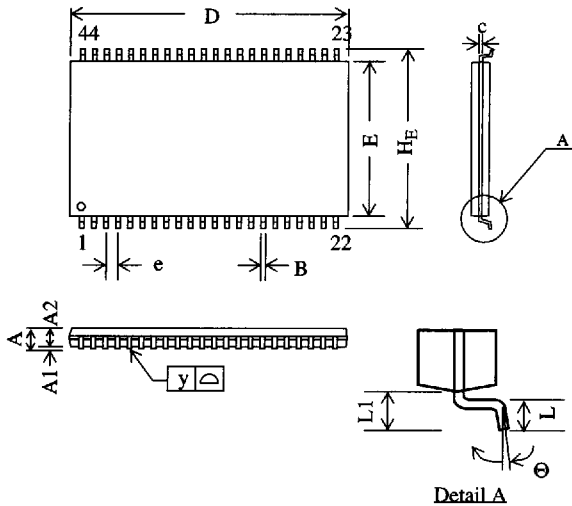

Symbol	Dimension in inch			Dimension in mm		
	min	nom	max	min	nom	max
A	-	-	0.047	-	-	1.20
A1	0.002	-	-	0.05	-	-
A2	0.037	0.039	0.041	0.95	1.00	1.05
B	0.01	0.014	0.018	0.25	0.35	0.45
c	-	0.006	-	-	0.15	-
D	0.721	0.725	0.729	18.31	18.41	18.51
E	0.396	0.400	0.404	10.06	10.16	10.26
e	-	0.031	-	-	0.80	-
H _E	0.455	0.463	0.471	11.56	11.76	11.96
L	0.016	0.020	0.024	0.40	0.50	0.60
L1	-	0.031	-	-	0.80	-
y	-	-	0.004	-	-	0.10
Θ	0°	-	5°	0°	-	5°

Note:

1. Dimension D & E do not include interlead flash
2. Dimension B does not include dambar protrusion / intrusion
3. Controlling dimension: mm

44 Pin SOL, 400 mil

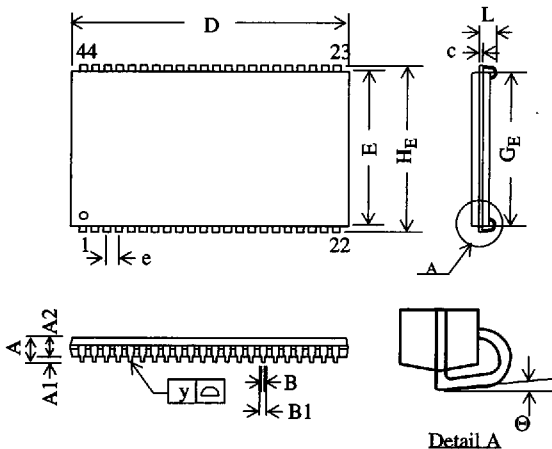

Symbol	Dimension in inch			Dimension in mm		
	min	nom	max	min	nom	max
A	-	-	0.148	-	-	3.759
A1	0.025	-	-	0.635	-	-
A2	0.105	0.110	0.115	2.667	2.794	2.921
B	-	0.018	-	-	0.457	-
B1	0.026	0.028	0.032	0.660	0.711	0.813
c	-	0.008	-	-	0.203	-
D	1.120	1.125	1.130	28.44	28.58	28.70
E	0.395	0.400	0.405	10.033	10.160	10.287
e	-	0.05	-	-	1.27	-
H _E	0.435	0.440	0.445	11.049	11.176	11.303
G _E	0.360	0.370	0.380	9.144	9.398	9.652
L	0.082	0.087	0.106	2.083	2.210	2.70
y	-	-	0.004	-	-	0.102
Θ	0°	-	7°	0°	-	7°

Note:

1. Dimension D & E do not include interlead flash
2. Dimension B1 does not include dambar protrusion / intrusion
3. Controlling dimension: inches

36 Pin SOJ, 400 mil

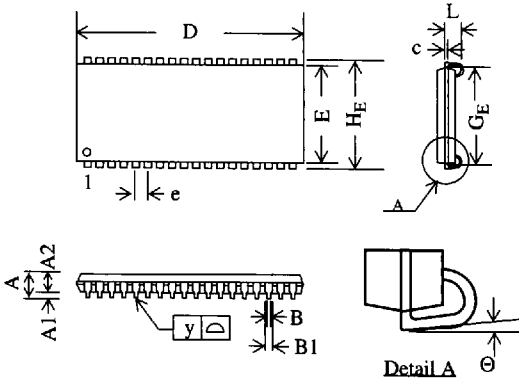

Symbol	Dimension in inch			Dimension in mm		
	min	nom	max	min	nom	max
A	-	-	0.146	-	-	3.70
A1	0.026	-	-	0.66	-	-
A2	0.105	0.110	0.115	2.67	2.80	2.92
B	0.013	0.017	0.021	0.33	0.43	0.53
B1	0.024	0.028	0.032	0.61	0.71	0.81
c	0.006	0.008	0.012	0.15	0.20	0.30
D	0.920	0.924	0.929	23.37	23.47	23.60
E	0.395	0.400	0.405	10.04	10.16	10.28
e	-	0.05	-	-	1.27	-
H _E	0.430	0.435	0.440	10.93	11.05	11.17
G _E	0.354	0.366	0.378	9.00	9.30	9.60
L	0.082	-	-	2.08	-	-
y	-	-	0.004	-	-	0.10
Θ	0°	-	10°	0°	-	10°

Note:

1. Dimension D & E do not include interlead flash
2. Dimension B1 does not include dambar protrusion / intrusion
3. Controlling dimension: inches

Package Dimension

100 pin TQFP

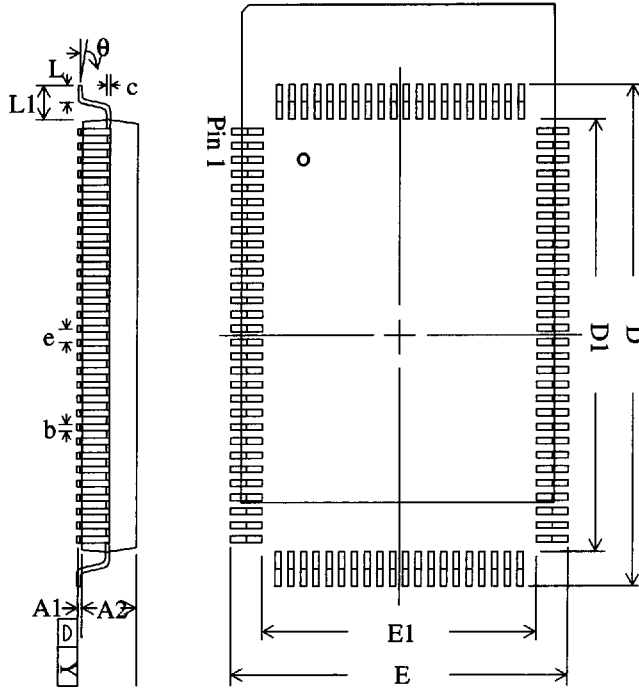

Symbol	Description	QFP (Q)			TQFP (T)		
		Min.	Nom.	Max	Min.	Nom.	Max
A1	Stand Off	0.25	0.35	0.45	0.05	0.10	0.15
A2	Body Thickness	2.55	2.72	2.90	1.35	1.40	1.45
b	Lead Width	0.20	0.30	0.40	0.20	0.30	0.40
c	Lead Thickness	0.10	0.15	0.20	0.09		0.20
D	Terminal Dimension	22.95	23.2	23.45	21.9	22.0	22.1
D1	Package Body	19.9	20.0	20.1	19.9	20.0	20.1
E	Terminal Dimension	17.0	17.2	17.4	15.9	16.0	16.1
E1	Package Body	13.9	14.0	14.1	13.9	14.0	14.1
e	Lead Pitch		0.65			0.65	
L	Foot Length	0.60	0.80	1.00	0.45	0.60	0.75
L1	Lead Length		1.60			1.00	
Y	Coplanarity			0.10			0.10
θ	Lead Angle	0°		7°	0°		7°

Note:

1. All dimensions are in millimeters (mm).
2. Package width and length do not include mold protrusion.