

## 320 x 240 Graphic LCD

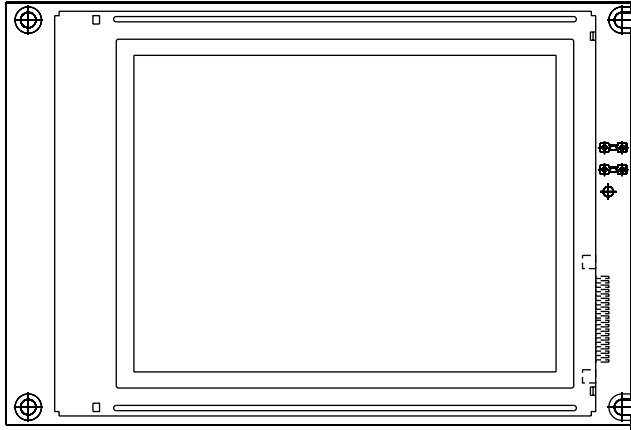

### FEATURES

- Type: Graphic
- Display format: 320 x 240 dots
- Built-in controller: Epson S1D13700
- Duty cycle: 1/240
- Built-in N.V.
- Touch screen option
- Temperature compensation option
- Same size with LCD-320H240D
- Compliant to RoHS directive 2002/95/EC

**RoHS**  
COMPLIANT

### MECHANICAL DATA

ITEM	STANDARD VALUE	UNIT
Module Dimension	142.0 x 96.0	mm
Viewing Area	104.0 x 79.3	
Dot Size	0.27 x 0.27	
Dot Pitch	0.30 x 0.30	
Mounting Hole	135.0 x 92.0	
Character Size	N/a	

### ABSOLUTE MAXIMUM RATINGS

ITEM	SYMBOL	STANDARD VALUE			UNIT
		MIN.	TYP.	MAX.	
Power Supply	$V_{DD}$ to $V_{SS}$	4.75	5.0	5.5	V
Input Voltage	$V_I$	- 0.3	-	$V_{DD}$	

#### Note

- $V_{SS} = 0$  V,  $V_{DD} = 5.0$  V

### ELECTRICAL CHARACTERISTICS

ITEM	SYMBOL	CONDITION	STANDARD VALUE			UNIT
			MIN.	TYP.	MAX.	
Input Voltage	$V_{DD}$	-	-	5.0	5.5	V
Supply Current	$I_{DD}$	$V_{DD} = + 5.0$ V	45.0	55.0	65.0	mA
Recommended LC Driving Voltage for Normal Temperature Version Module	$V_0$ to $V_{SS}$	- 20 °C	-	-	26.1	V
		25 °C	-	23.8	-	
		70 °C	20.9	-	-	
CCFL Starting Voltage	$V_{FLS}$	25 °C	-	600	-	$V_{RMS}$
CCFL Driving Voltage	$V_{FLD}$	25 °C	-	268	-	$V_{RMS}$
CCFL Driving Current	$I_{FLD}$	$V_{FQ} = 450 V_{RMS}, 30$ kHz	-	5.0	-	$mA_{RMS}$
LED Forward Voltage	$V_F$	25 °C	-	5.0	5.5	V
LED Forward Current	$I_F$	25 °C	-	80.0	-	mA
EL Power Supply Current	$I_{EF}$	$V_{EL} = 110 V_{AC}, 400$ Hz	-	-	5.0	mA

### OPTIONS

PROCESS COLOR						BACKLIGHT			
TN	STN Gray	STN Yellow	STN Blue	FSTN B&W	STN Color	None	LED	EL	CCFL
	x	x	x	x		x	x		x

For detailed information, please see the "Product Numbering System" document.

INTERFACE PIN FUNCTION		
PIN NO.	SYMBOL	FUNCTION
1	V <sub>SS</sub>	Ground
2	V <sub>DD</sub>	Power supply for logic
3	V <sub>0</sub>	Driving voltage for LCD
4	A <sub>0</sub>	RD = L, WR = H; AO = L: Data read; AO = H: Status read RD = H, WR = L; AO = L: Data write; AO = H: Command write
5	$\overline{WR}$	8080 family: Write signal/6800 family: R/W signal
6	$\overline{RD}$	8080 family: Read signal/6800 family: Enable clock
7	DB0	Date bus line
8	DB1	Date bus line
9	DB2	Date bus line
10	DB3	Date bus line
11	DB4	Date bus line
12	DB5	Date bus line
13	$\overline{DB6}$	Date bus line
14	$\overline{DB7}$	Date bus line
15	CS	Chip select, active L
16	RES	Controller reset signal, active L
17	V <sub>EE</sub>	Negative voltage output
18	SEL1	H: 68/L: 80
19	BUSY	Check busy
20	A	+ 5 V for LED

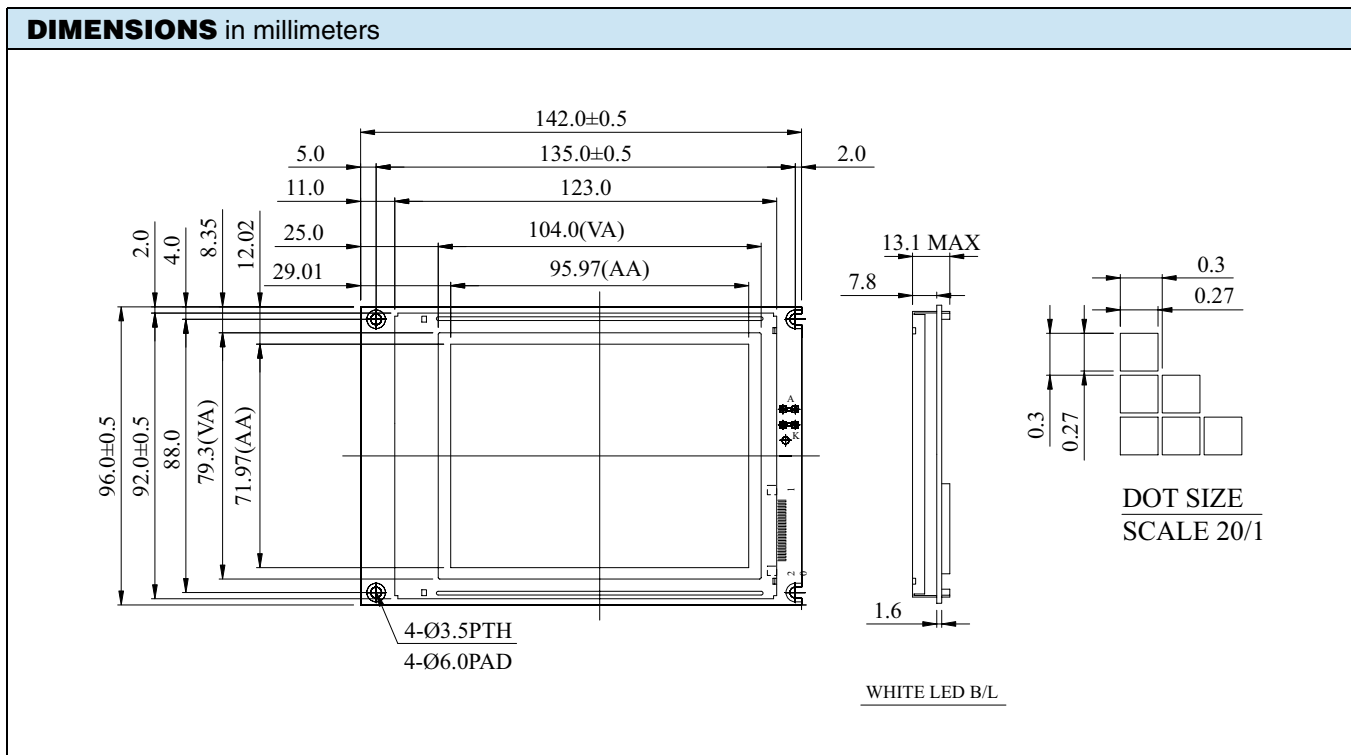



## Disclaimer

All product specifications and data are subject to change without notice.

Vishay Intertechnology, Inc., its affiliates, agents, and employees, and all persons acting on its or their behalf (collectively, "Vishay"), disclaim any and all liability for any errors, inaccuracies or incompleteness contained herein or in any other disclosure relating to any product.

Vishay disclaims any and all liability arising out of the use or application of any product described herein or of any information provided herein to the maximum extent permitted by law. The product specifications do not expand or otherwise modify Vishay's terms and conditions of purchase, including but not limited to the warranty expressed therein, which apply to these products.

No license, express or implied, by estoppel or otherwise, to any intellectual property rights is granted by this document or by any conduct of Vishay.

The products shown herein are not designed for use in medical, life-saving, or life-sustaining applications unless otherwise expressly indicated. Customers using or selling Vishay products not expressly indicated for use in such applications do so entirely at their own risk and agree to fully indemnify Vishay for any damages arising or resulting from such use or sale. Please contact authorized Vishay personnel to obtain written terms and conditions regarding products designed for such applications.

Product names and markings noted herein may be trademarks of their respective owners.