

FEATURES

- *Guaranteed* $\pm 4\text{mV}$ initial accuracy LT1004-1.2
- *Guaranteed* $\pm 20\text{mV}$ accuracy LT1004-2.5
- *Guaranteed* $10\mu\text{A}$ operating current
- *Guaranteed* temperature performance
- Operates up to 20mA
- Very low dynamic impedance

APPLICATIONS

- Portable meter references
- Portable test instruments
- Battery operated systems
- Current loop instrumentation

DESCRIPTION

The LT1004 Micropower Voltage References are two terminal bandgap reference diodes designed to provide high accuracy and excellent temperature characteristics at very low operating currents. Optimization of the key parameters in the design, processing and testing of the device results in accuracy specifications previously attainable only with selected units. Below is a distribution plot of reference voltage for a typical lot of LT1004-1.2. Virtually all of the units fall well within the prescribed limits of $\pm 4\text{mV}$.

The LT1004 is a pin for pin replacement for the LM185/385 series of references with improved accuracy specifications. More important, the LT1004 is an attractive device for use in systems where accuracy was previously obtained at the expense of power consumption and trimming.

For a low drift micropower reference with guaranteed temperature coefficient, see the LT1034 data sheet.

3

Micropower Cold Junction Compensation For Thermocouples

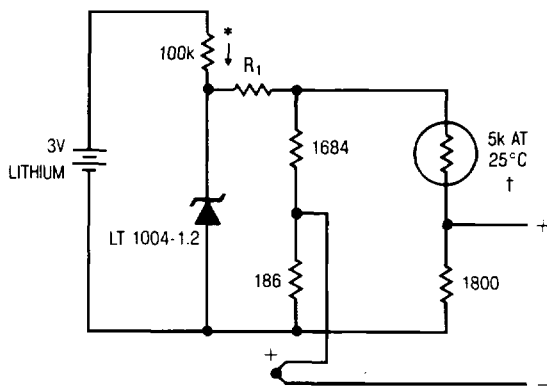

THERMOCOUPLE TYPE	R ₁
J	233k
K	299k
T	300k
S	2.1M

* QUIESCENT CURRENT $\approx 15\mu\text{A}$
 † YELLOW SPRINGS INST. CO. PART #44007
 COMPENSATES WITHIN $\pm 1^\circ\text{C}$ FROM 0°C TO 60°C

Typical Distribution of Reference Voltage (LT1004-1.2)

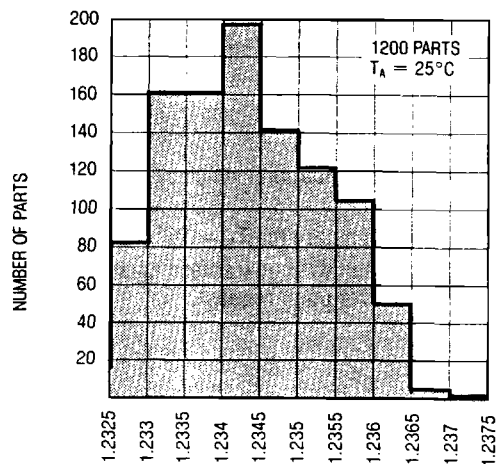

ABSOLUTE MAXIMUM RATINGS

Reverse Breakdown Current..... 30mA
 Forward Current..... 10mA
 Operating Temperature Range
 LT1004M -55°C to 125°C
 LT1004C 0°C to 70°C
 Storage Temperature Range
 LT1004M -65°C to 150°C
 LT1004C -65°C to 150°C
 Lead Temperature (Soldering, 10 sec.)..... 300°C

PACKAGE/ORDER INFORMATION

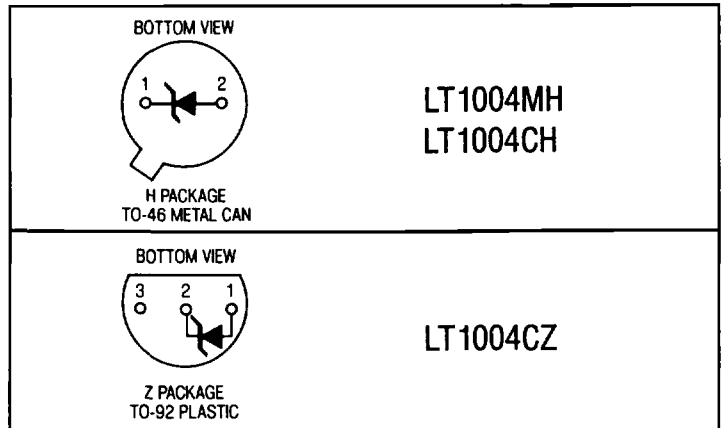

ELECTRICAL CHARACTERISTICS (See Note 1)

SYMBOL	PARAMETER	CONDITIONS	LT1004-1.2			LT1004-2.5			UNITS	
			MIN	TYP	MAX	MIN	TYP	MAX		
V _Z	Reverse Breakdown Voltage	I _R = 100μA	●	1.231	1.235	1.239	2.480	2.500	2.520	V
		LT1004M -55°C ≤ T _A ≤ 125°C	●	1.220	1.230	1.245	2.460	2.500	2.535	V
		LT1004M/C 0°C ≤ T _A ≤ 70°C	●	1.225	1.235	1.245	2.470	2.500	2.530	V
$\frac{\Delta V_Z}{\Delta \text{Temp}}$	Average Temperature Coefficient	I _{min} ≤ I _R ≤ 20mA (Note 2)		20		20			ppm/°C	
I _{min}	Minimum Operating Current		●	8	10	12	20		μA	
$\frac{\Delta V_Z}{\Delta I_R}$	Reverse Breakdown Voltage Change with Current	I _{min} ≤ I _R ≤ 1mA	●	1		1			mV	
		1mA ≤ I _R ≤ 20mA	●	1.5		1.5			mV	
			●	10		10			mV	
r _Z	Reverse Dynamic Impedance	I _R = 100μA	●	0.2	0.6	0.2	0.6		Ω	
			●	1.5		1.5			Ω	
e _n	Wide Band Noise (RMS)	I _R = 100μA 10Hz ≤ f ≤ 10kHz		60		120			μV	
$\frac{\Delta V_Z}{\Delta \text{Time}}$	Long Term Stability	I _R = 100μA T _A = 25°C ± 0.1°C		20		20			ppm/kHr	

The ● denotes the specifications which apply over the full operating temperature range.

Note 1: All specifications are for T_A = 25°C unless otherwise noted.

Note 2: Selected devices with guaranteed maximum temperature coefficient are available upon request.

TYPICAL PERFORMANCE CHARACTERISTICS 1.2 VOLT

Reverse Characteristics

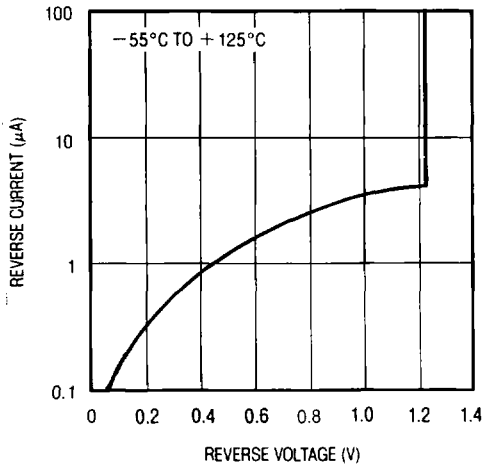

Reverse Voltage Change

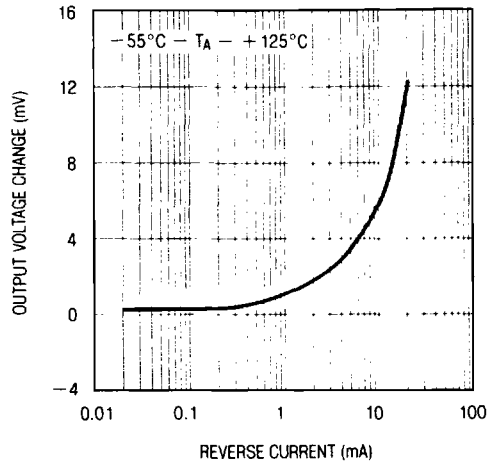

Forward Characteristics

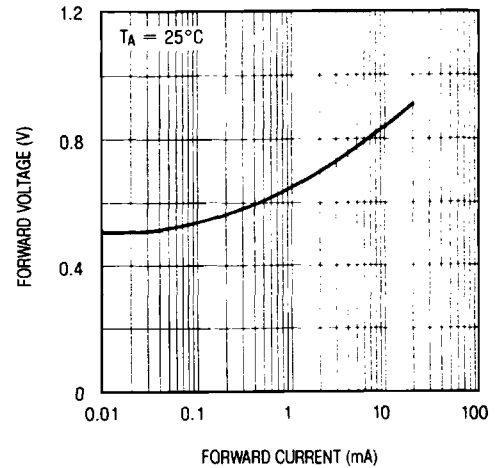

Temperature Drift

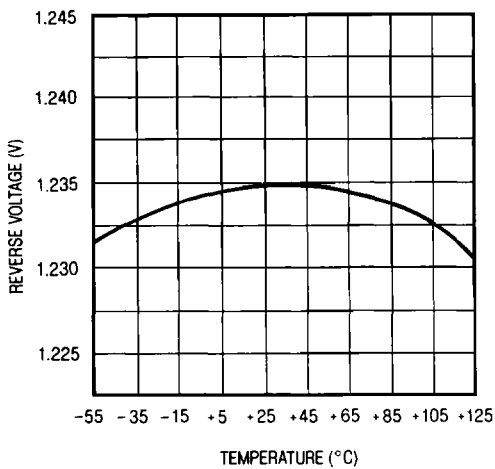

Reverse Dynamic Impedance

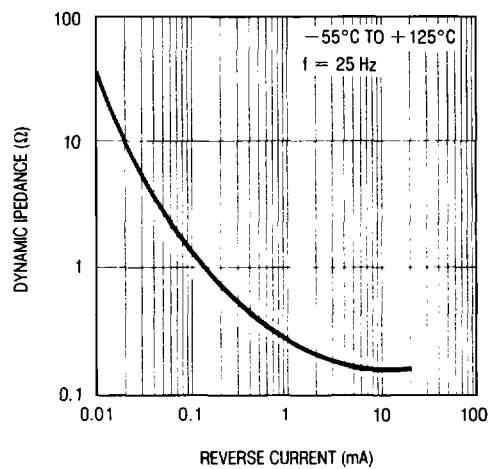

Reverse Dynamic Impedance

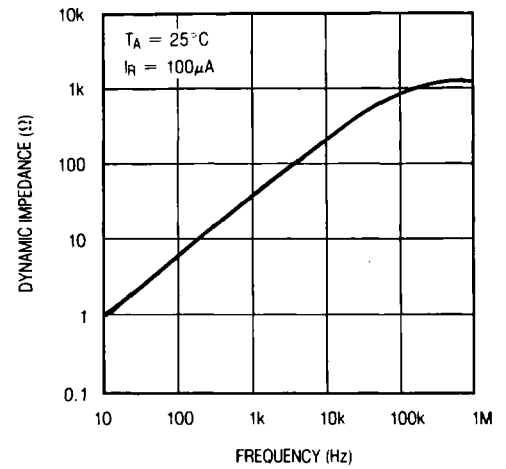

3

Noise Voltage

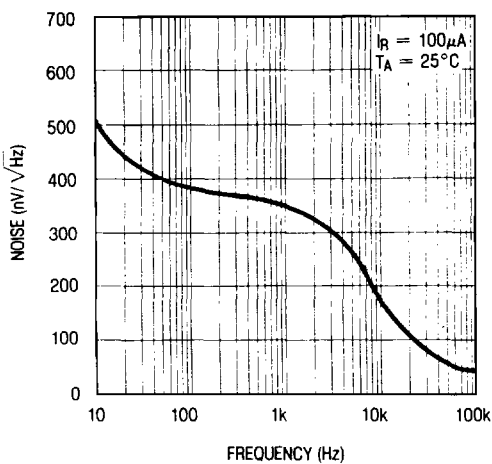

Filtered Output Noise

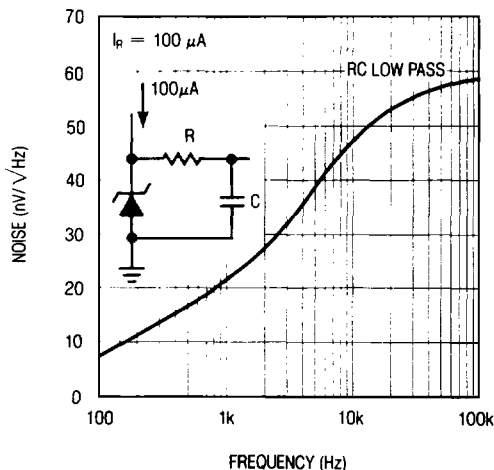

Response Time

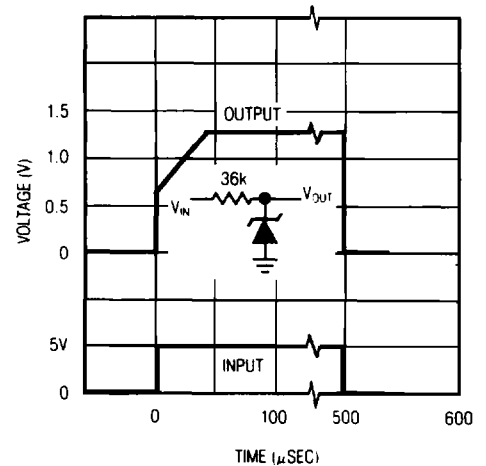

TYPICAL PERFORMANCE CHARACTERISTICS 2.5 VOLT

Reverse Characteristics

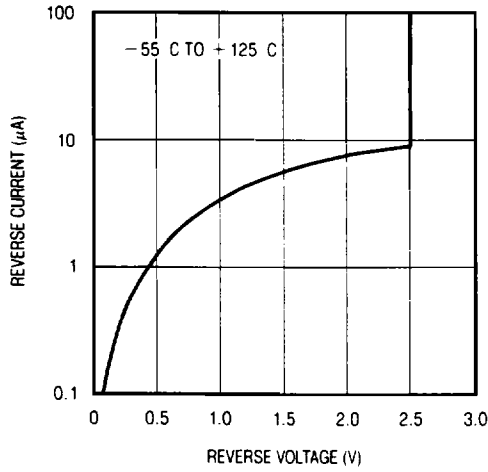

Forward Characteristics

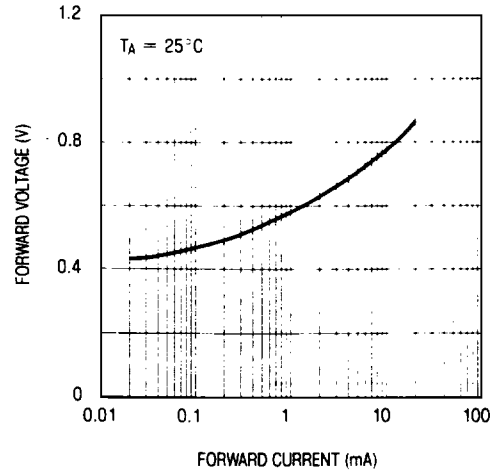

Temperature Drift

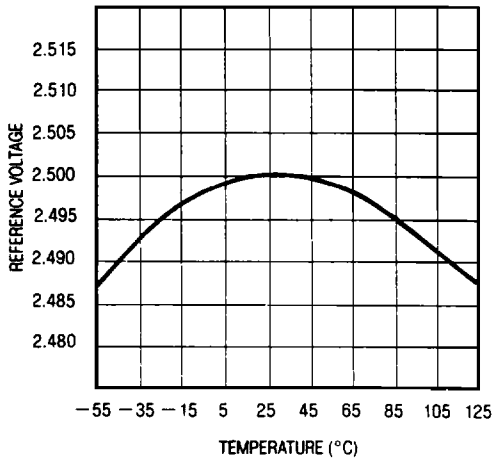

Reverse Dynamic Impedance

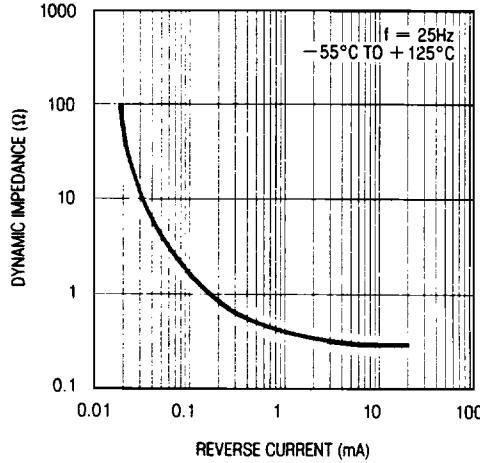

Reverse Dynamic Impedance

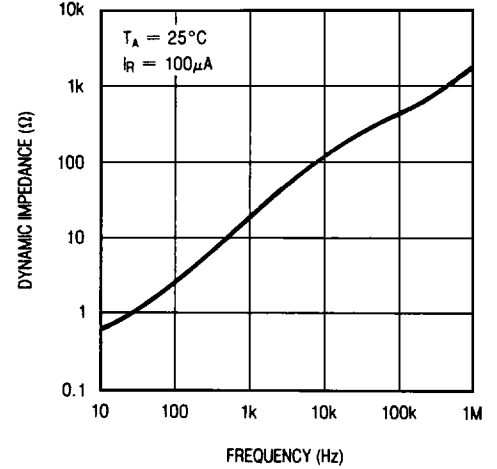

Noise Voltage

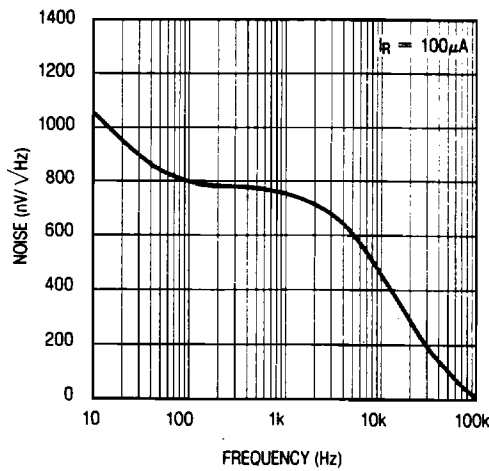

Filtered Output Noise

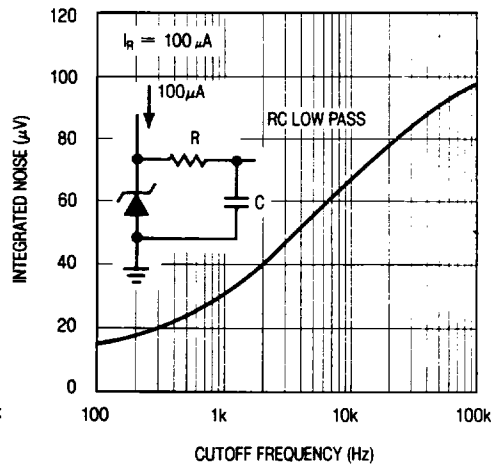

Response Time

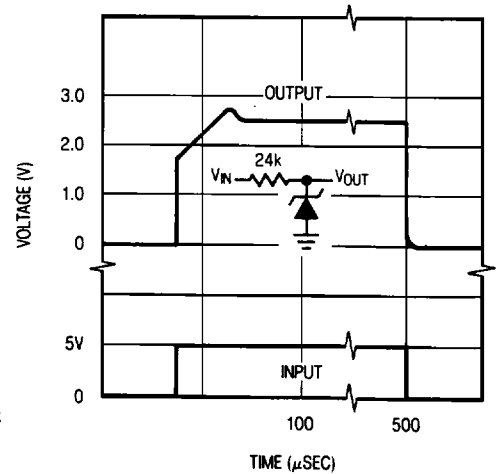

TYPICAL APPLICATIONS

High Stability 5V Regulator

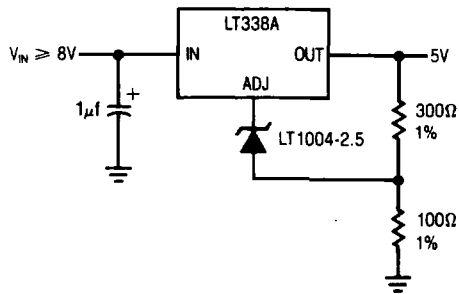

Ground Referenced Current Source

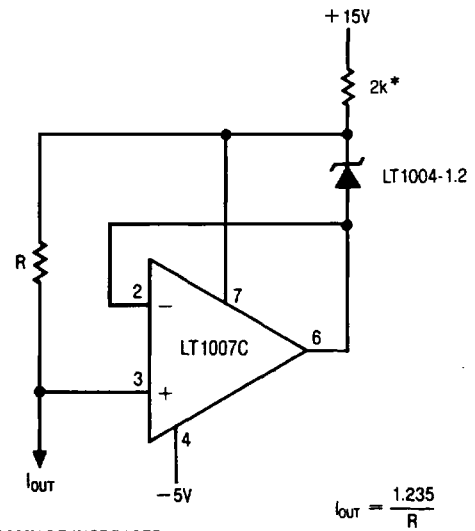

* MAY BE INCREASED FOR SMALL OUTPUT CURRENTS

$$R \approx \frac{2V}{I_{OUT} + 10\mu A}$$

$$I_{OUT} = \frac{1.235}{R}$$

0-100°C Linear Output Thermometer

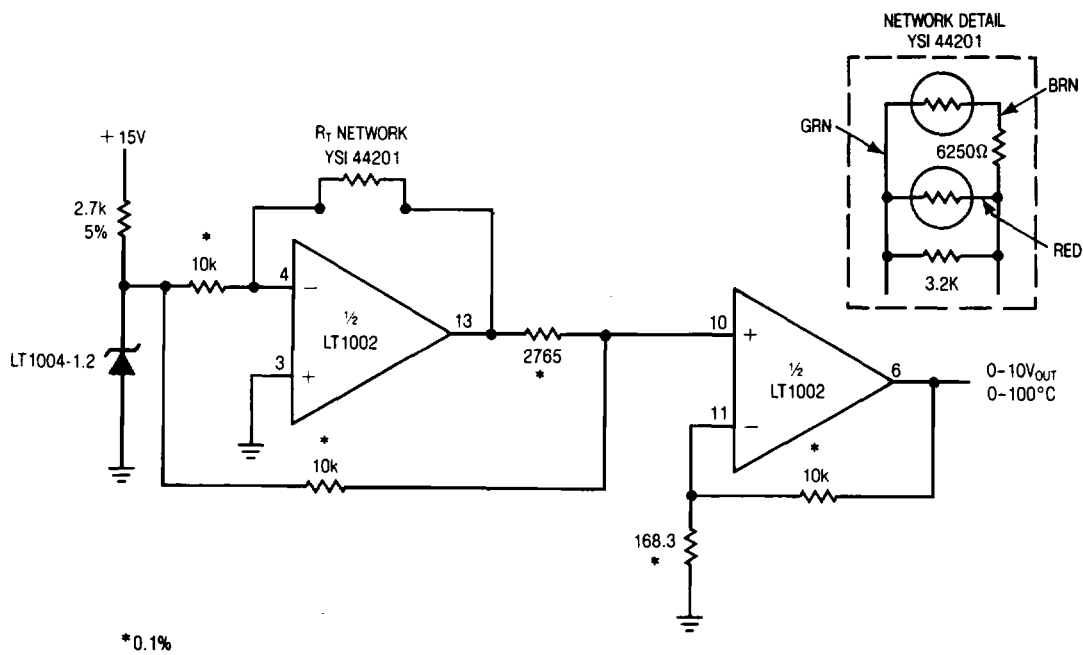

*0.1%

3

TYPICAL APPLICATIONS

**Low Temperature Coefficient
2 Terminal Current Source**

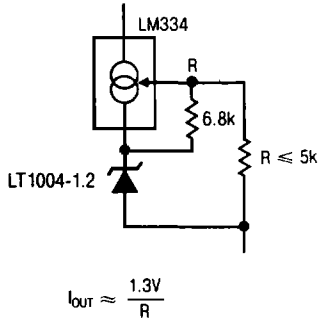

**Constant Gain Amplifier
Over Temperature**

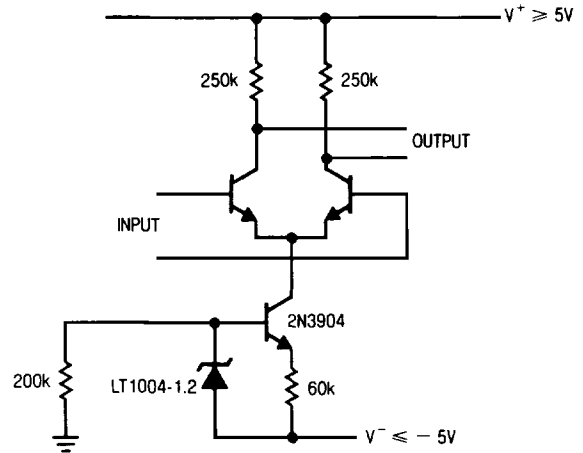

Variable Output Supply

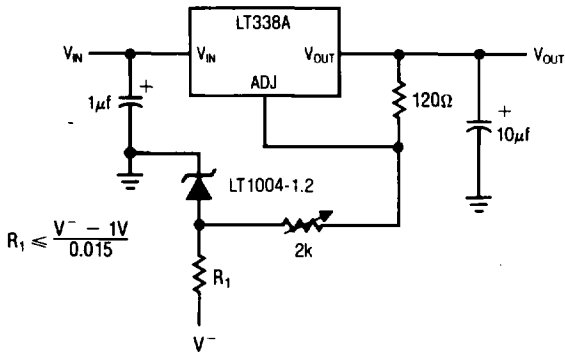

Low Noise Reference

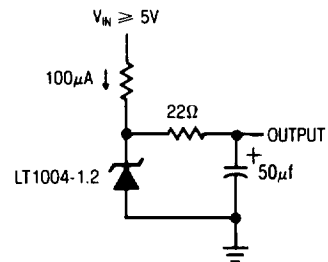

2.5V Reference

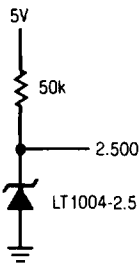

**Micropower Reference
from 9V Battery**

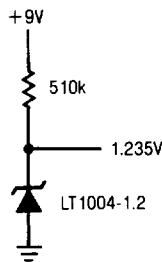

1.2V Reference from 1.5V Battery

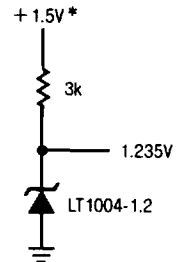

* OUTPUT REGULATES
DOWN TO 1.285V
FOR $I_{out} = 0$

TYPICAL APPLICATIONS

Micropower 5V Reference

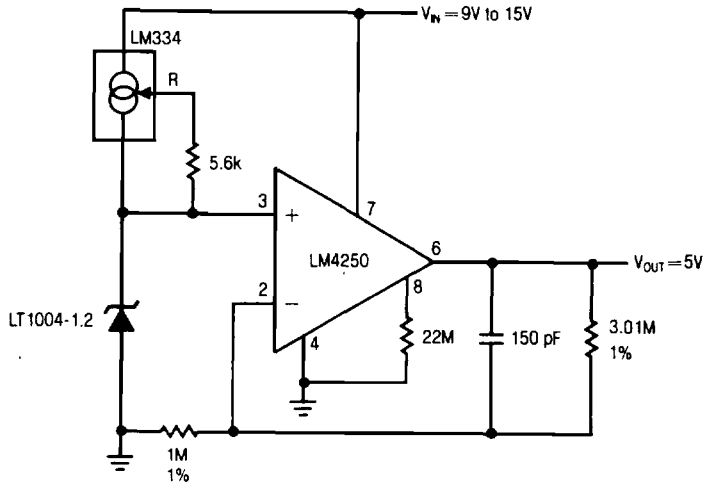

Lead Acid Low Battery Detector

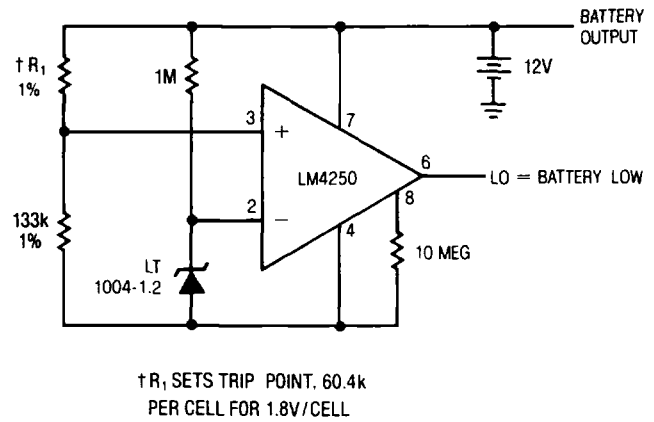

3

V_{pp} Generator for Eeproms — No Trim Required

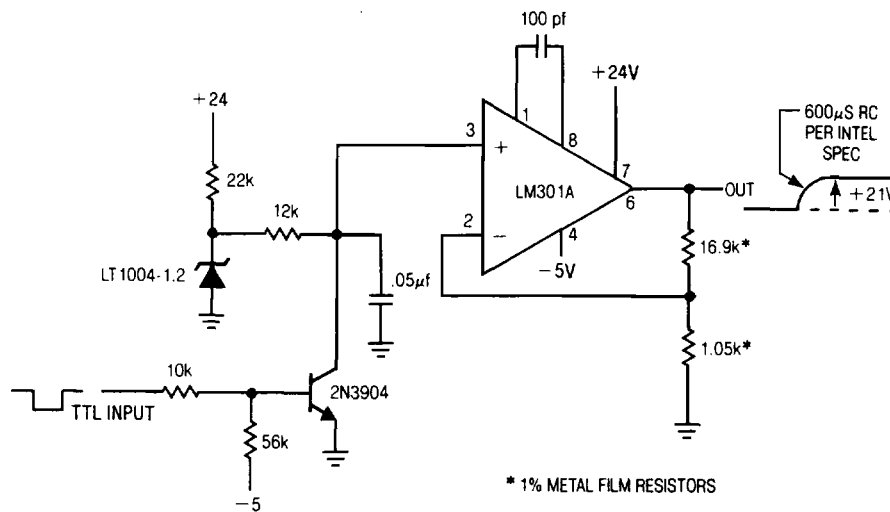

SCHEMATIC DIAGRAM

LT1004-1.2

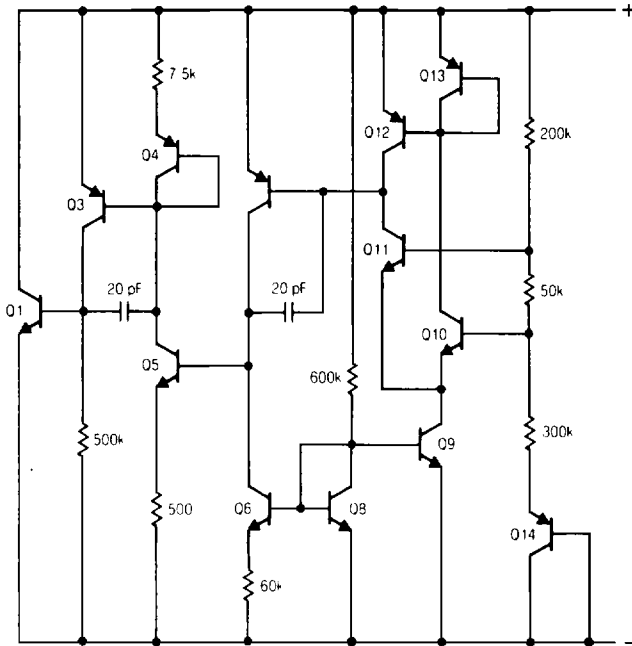

LT1004-2.5

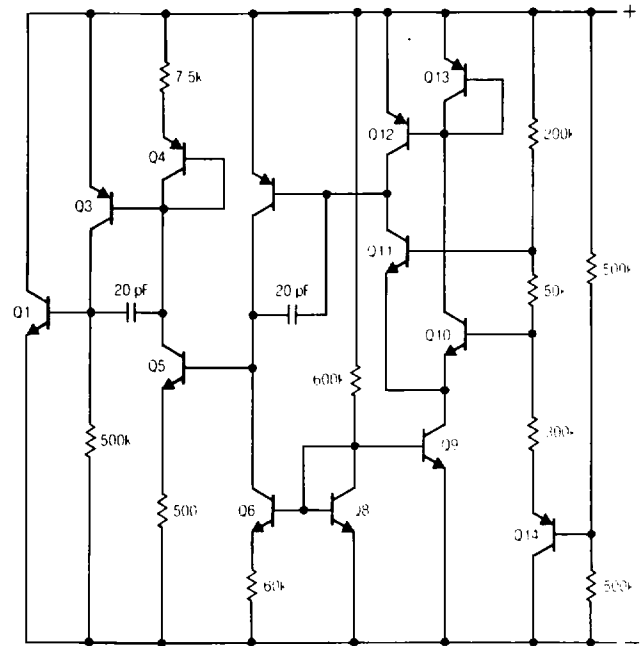

PACKAGE DESCRIPTION Dimensions in inches (millimeters) unless otherwise noted.

H Package, 2 Lead TO-46 Metal Can

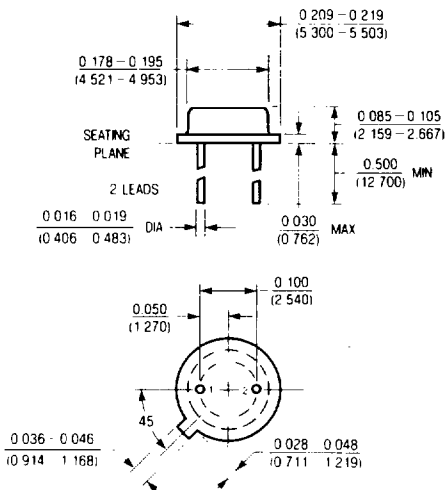

T_{jmax}	θ_{ja}	θ_{jc}
150°C	440°C/W	80°C/W

Z Package, 3 Lead TO-92 Plastic

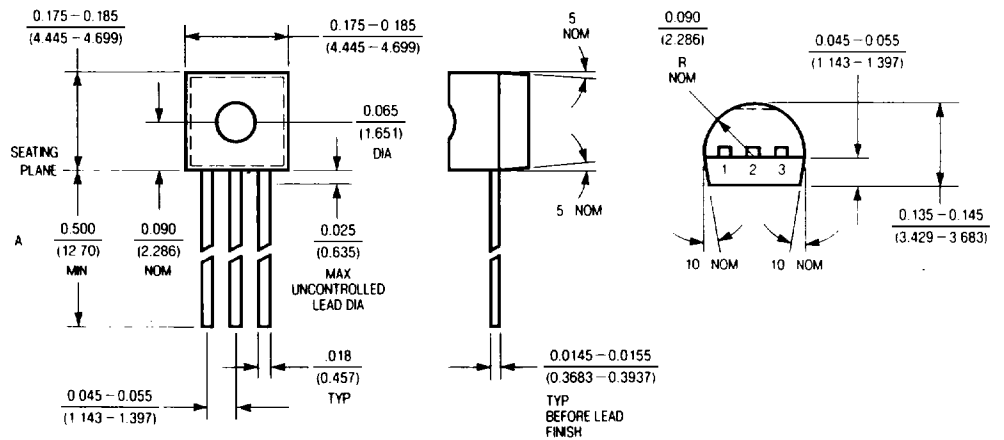

T_{jmax}	θ_{ja}
100°C	160°C/W