

# OKI Semiconductor

## MSM5116160A

1,048,576-Word × 16-Bit DYNAMIC RAM : FAST PAGE MODE TYPE

### DESCRIPTION

The MSM5116160A is a 1,048,576-word × 16-bit dynamic RAM fabricated in OKI's CMOS silicon gate technology. The MSM5116160A achieves high integration, high-speed operation, and low-power consumption due to quadruple polysilicon double metal CMOS. The MSM5116160A is available in a 42-pin plastic SOJ or 50/44-pin plastic TSOP.

### FEATURES

- 1,048,576-word × 16-bit configuration
- Single 5 V power supply, ±10% tolerance
- Input : TTL compatible, low input capacitance
- Output : TTL compatible, 3-state
- Refresh : 4096 cycles/64 ms
- Fast page mode, read modify write capability
- $\overline{\text{CAS}}$  before  $\overline{\text{RAS}}$  refresh, hidden refresh,  $\overline{\text{RAS}}$ -only refresh capability
- Package options:  
 42-Pin 400 mil plastic SOJ (SOJ42-P-400) (Product : MSM5116160A-xxJS)  
 50/44-Pin 400 mil plastic TSOP (TSOP50/44-P-400/0.8-K) (Product : MSM5116160A-xxTS-K)  
 xx indicates speed rank.

### PRODUCT FAMILY

Family	Access Time (Max.)				Cycle Time (Min.)	Power Dissipation	
	t <sub>RAC</sub>	t <sub>AA</sub>	t <sub>CAC</sub>	t <sub>OEA</sub>		Operating (Max.)	Standby (Max.)
MSM5116160A-60	60 ns	30 ns	15 ns	15 ns	110 ns	605 mW	5.5 mW
MSM5116160A-70	70 ns	35 ns	20 ns	20 ns	130 ns	550 mW	
MSM5116160A-80	80 ns	40 ns	20 ns	20 ns	150 ns	495 mW	

## PIN CONFIGURATION (TOP VIEW)

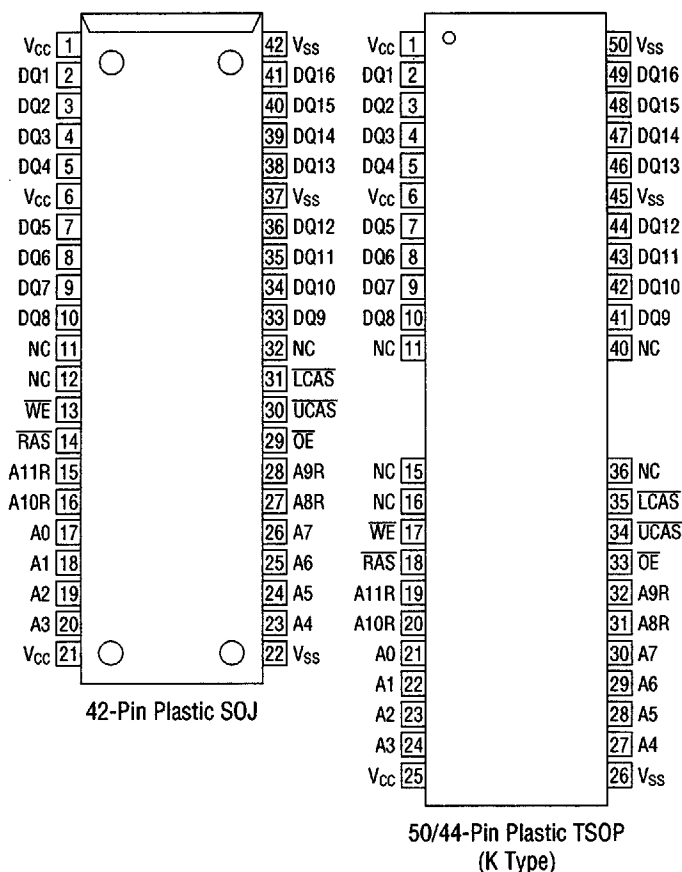

Pin Name	Function
A0 - A7, A8R - A11R	Address Input
RAS	Row Address Strobe
LCAS	Lower Byte Column Address Strobe
UCAS	Upper Byte Column Address Strobe
DQ1 - DQ16	Data Input/Data Output
OE	Output Enable
WE	Write Enable
V <sub>CC</sub>	Power Supply (5 V)
V <sub>SS</sub>	Ground (0 V)
NC	No Connection

Note: The same power supply voltage must be provided to every V<sub>CC</sub> pin, and the same GND voltage level must be provided to every V<sub>SS</sub> pin.

**BLOCK DIAGRAM**

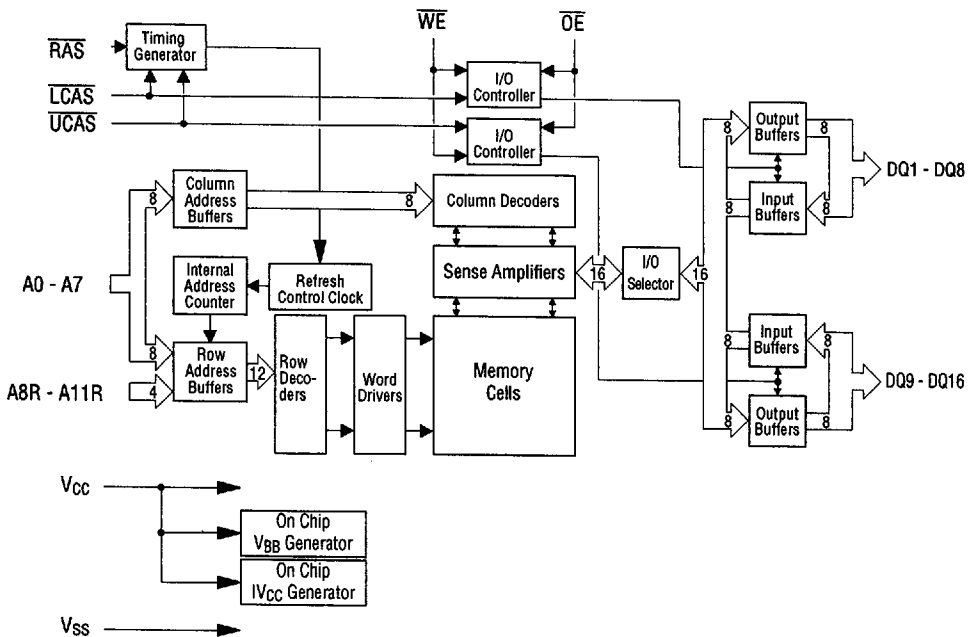

**FUNCTION TABLE**

Input Pin					DQ Pin		Function Mode
RAS	LCAS	UCAS	WE	OE	DQ1 - DQ8	DQ9 - DQ16	
H	*	*	*	*	High-Z	High-Z	Standby
L	H	H	*	*	High-Z	High-Z	Refresh
L	L	H	H	L	D <sub>OUT</sub>	High-Z	Lower Byte Read
L	H	L	H	L	High-Z	D <sub>OUT</sub>	Upper Byte Read
L	L	L	H	L	D <sub>OUT</sub>	D <sub>OUT</sub>	Word Read
L	L	H	L	H	D <sub>IN</sub>	Don't Care	Lower Byte Write
L	H	L	L	H	Don't Care	D <sub>IN</sub>	Upper Byte Write
L	L	L	L	H	D <sub>IN</sub>	D <sub>IN</sub>	Word Write
L	L	L	H	H	High-Z	High-Z	—

\*: "H" or "L"

**ELECTRICAL CHARACTERISTICS****Absolute Maximum Ratings**

Parameter	Symbol	Rating	Unit
Voltage on Any Pin Relative to $V_{SS}$	$V_T$	-1.0 to 7.0	V
Short Circuit Output Current	$I_{OS}$	50	mA
Power Dissipation	$P_D^*$	1	W
Operating Temperature	$T_{opr}$	0 to 70	°C
Storage Temperature	$T_{stg}$	-55 to 150	°C

\*:  $T_a = 25^\circ\text{C}$ **Recommended Operating Conditions** $(T_a = 0^\circ\text{C to } 70^\circ\text{C})$ 

Parameter	Symbol	Min.	Typ.	Max.	Unit
Power Supply Voltage	$V_{CC}$	4.5	5.0	5.5	V
	$V_{SS}$	0	0	0	V
Input High Voltage	$V_{IH}$	2.4	—	6.5	V
Input Low Voltage	$V_{IL}$	-1.0	—	0.8	V

**Capacitance** $(V_{CC} = 5\text{ V} \pm 10\%, T_a = 25^\circ\text{C}, f = 1\text{ MHz})$ 

Parameter	Symbol	Typ.	Max.	Unit
Input Capacitance (A0 - A7, A8R - A11R)	$C_{IN1}$	—	5	pF
Input Capacitance (RAS, LCAS, UCAS, WE, OE)	$C_{IN2}$	—	7	pF
Output Capacitance (DQ1 - DQ16)	$C_{I/O}$	—	7	pF

DC Characteristics

( $V_{CC} = 5V \pm 10\%$ ,  $T_a = 0^\circ C$  to  $70^\circ C$ )

Parameter	Symbol	Condition	MSM5116160 A-60		MSM5116160 A-70		MSM5116160 A-80		Unit	Note
			Min.	Max.	Min.	Max.	Min.	Max.		
			Output High Voltage	$V_{OH}$	$I_{OH} = -5.0$ mA	2.4	$V_{CC}$	2.4		
Output Low Voltage	$V_{OL}$	$I_{OL} = 4.2$ mA	0	0.4	0	0.4	0	0.4	V	
Input Leakage Current	$I_{LI}$	$0V \leq V_I \leq 6.5V$ ; All other pins not under test = 0 V	-10	10	-10	10	-10	10	$\mu A$	
Output Leakage Current	$I_{LO}$	DQ disable $0V \leq V_O \leq 5.5V$	-10	10	-10	10	-10	10	$\mu A$	
Average Power Supply Current (Operating)	$I_{CC1}$	$\overline{RAS}$ , $\overline{CAS}$ cycling, $t_{RC} = \text{Min.}$	—	110	—	100	—	90	mA	1, 2
Power Supply Current (Standby)	$I_{CC2}$	$\overline{RAS}$ , $\overline{CAS} = V_{IH}$	—	2	—	2	—	2	mA	1
		$\overline{RAS}$ , $\overline{CAS}$ $\geq V_{CC} - 0.2V$	—	1	—	1	—	1		
Average Power Supply Current (RAS-only Refresh)	$I_{CC3}$	$\overline{RAS}$ cycling, $\overline{CAS} = V_{IH}$ , $t_{RC} = \text{Min.}$	—	110	—	100	—	90	mA	1, 2
Power Supply Current (Standby)	$I_{CC5}$	$\overline{RAS} = V_{IH}$ , $\overline{CAS} = V_{IL}$ , DQ = enable	—	5	—	5	—	5	mA	1
Average Power Supply Current ( $\overline{CAS}$ before $\overline{RAS}$ Refresh)	$I_{CC6}$	$\overline{RAS}$ cycling, $\overline{CAS}$ before $\overline{RAS}$	—	110	—	100	—	90	mA	1, 2
Average Power Supply Current (Fast Page Mode)	$I_{CC7}$	$\overline{RAS} = V_{IL}$ , $\overline{CAS}$ cycling, $t_{PC} = \text{Min.}$	—	100	—	90	—	80	mA	1, 3

- Notes :
1.  $I_{CC}$  Max. is specified as  $I_{CC}$  for output open condition.
  2. Address can be changed once or less while  $\overline{RAS} = V_{IL}$ .
  3. Address can be changed once or less while  $\overline{CAS} = V_{IH}$ .

## AC Characteristics (1/2)

(V<sub>CC</sub> = 5 V ±10%, T<sub>a</sub> = 0°C to 70°C) Note 1, 2, 3

Parameter	Symbol	MSM5116160 A-60		MSM5116160 A-70		MSM5116160 A-80		Unit	Note
		Min.	Max.	Min.	Max.	Min.	Max.		
Random Read or Write Cycle Time	t <sub>RC</sub>	110	—	130	—	150	—	ns	
Read Modify Write Cycle Time	t <sub>RWC</sub>	150	—	180	—	200	—	ns	
Fast Page Mode Cycle Time	t <sub>PC</sub>	40	—	45	—	50	—	ns	
Fast Page Mode Read Modify Write Cycle Time	t <sub>PRWC</sub>	80	—	95	—	100	—	ns	
Access Time from $\overline{\text{RAS}}$	t <sub>RAC</sub>	—	60	—	70	—	80	ns	4, 5, 6
Access Time from $\overline{\text{CAS}}$	t <sub>CAC</sub>	—	15	—	20	—	20	ns	4, 5
Access Time from Column Address	t <sub>AA</sub>	—	30	—	35	—	40	ns	4, 6
Access Time from $\overline{\text{CAS}}$ Precharge	t <sub>CPA</sub>	—	35	—	40	—	45	ns	4, 12
Access Time from $\overline{\text{OE}}$	t <sub>OEA</sub>	—	15	—	20	—	20	ns	4
Output Low Impedance Time from $\overline{\text{CAS}}$	t <sub>CLZ</sub>	0	—	0	—	0	—	ns	4
$\overline{\text{CAS}}$ to Data Output Buffer Turn-off Delay Time	t <sub>OFF</sub>	0	15	0	15	0	15	ns	7
$\overline{\text{OE}}$ to Data Output Buffer Turn-off Delay Time	t <sub>OEZ</sub>	0	15	0	15	0	15	ns	7
Transition Time	t <sub>r</sub>	3	50	3	50	3	50	ns	3
Refresh Period	t <sub>REF</sub>	—	64	—	64	—	64	ms	
$\overline{\text{RAS}}$ Precharge Time	t <sub>RP</sub>	40	—	50	—	60	—	ns	
$\overline{\text{RAS}}$ Pulse Width	t <sub>RAS</sub>	60	10,000	70	10,000	80	10,000	ns	
$\overline{\text{RAS}}$ Pulse Width (Fast Page Mode)	t <sub>RASP</sub>	60	100,000	70	100,000	80	100,000	ns	
$\overline{\text{RAS}}$ Hold Time	t <sub>RSH</sub>	15	—	20	—	20	—	ns	
$\overline{\text{RAS}}$ Hold Time referenced to $\overline{\text{OE}}$	t <sub>ROH</sub>	15	—	20	—	20	—	ns	
$\overline{\text{CAS}}$ Precharge Time (Fast Page Mode)	t <sub>CP</sub>	10	—	10	—	10	—	ns	14
$\overline{\text{CAS}}$ Pulse Width	t <sub>CAS</sub>	15	10,000	20	10,000	20	10,000	ns	
$\overline{\text{CAS}}$ Hold Time	t <sub>CSH</sub>	60	—	70	—	80	—	ns	
$\overline{\text{CAS}}$ to $\overline{\text{RAS}}$ Precharge Time	t <sub>CRP</sub>	5	—	5	—	5	—	ns	12
$\overline{\text{CAS}}$ to $\overline{\text{RAS}}$ Precharge Time	t <sub>RHCP</sub>	35	—	40	—	45	—	ns	12
$\overline{\text{RAS}}$ to $\overline{\text{CAS}}$ Delay Time	t <sub>RCD</sub>	20	45	20	50	20	60	ns	5
$\overline{\text{RAS}}$ to Column Address Delay Time	t <sub>RAD</sub>	15	30	15	35	15	40	ns	6
Row Address Set-up Time	t <sub>ASR</sub>	0	—	0	—	0	—	ns	
Row Address Hold Time	t <sub>RAH</sub>	10	—	10	—	10	—	ns	
Column Address Set-up Time	t <sub>ASC</sub>	0	—	0	—	0	—	ns	11
Column Address Hold Time	t <sub>CAH</sub>	15	—	15	—	15	—	ns	11
Column Address Hold Time from $\overline{\text{RAS}}$	t <sub>AR</sub>	50	—	55	—	60	—	ns	
Column Address to $\overline{\text{RAS}}$ Lead Time	t <sub>RAL</sub>	30	—	35	—	40	—	ns	
Read Command Set-up Time	t <sub>RCS</sub>	0	—	0	—	0	—	ns	11
Read Command Hold Time	t <sub>RCH</sub>	0	—	0	—	0	—	ns	8, 11
Read Command Hold Time referenced to $\overline{\text{RAS}}$	t <sub>RRH</sub>	0	—	0	—	0	—	ns	8

AC Characteristics (2/2)

(V<sub>CC</sub> = 5 V ±10%, T<sub>a</sub> = 0°C to 70°C) Note 1, 2, 3

Parameter	Symbol	MSM5116160 A-60		MSM5116160 A-70		MSM5116160 A-80		Unit	Note
		Min.	Max.	Min.	Max.	Min.	Max.		
		Write Command Set-up Time	t <sub>WCS</sub>	0	—	0	—		
Write Command Hold Time	t <sub>WCH</sub>	10	—	15	—	15	—	ns	11
Write Command Hold Time from RAS	t <sub>WCR</sub>	45	—	55	—	60	—	ns	
Write Command Pulse Width	t <sub>WP</sub>	10	—	15	—	15	—	ns	
OE Command Hold Time	t <sub>OEH</sub>	15	—	20	—	20	—	ns	
Write Command to RAS Lead Time	t <sub>RWL</sub>	15	—	20	—	20	—	ns	
Write Command to CAS Lead Time	t <sub>CWL</sub>	15	—	20	—	20	—	ns	13
Data-in Set-up Time	t <sub>DS</sub>	0	—	0	—	0	—	ns	10, 11
Data-in Hold Time	t <sub>DH</sub>	15	—	15	—	15	—	ns	10, 11
Data-in Hold Time from RAS	t <sub>DHR</sub>	50	—	55	—	60	—	ns	
OE to Data-in Delay Time	t <sub>OED</sub>	15	—	15	—	15	—	ns	
CAS to WE Delay Time	t <sub>CWD</sub>	35	—	45	—	45	—	ns	9
Column Address to WE Delay Time	t <sub>AWD</sub>	50	—	60	—	65	—	ns	9
RAS to WE Delay Time	t <sub>RWD</sub>	80	—	95	—	105	—	ns	9
CAS Precharge WE Delay Time	t <sub>CPWD</sub>	55	—	65	—	70	—	ns	9
CAS Active Delay Time from RAS Precharge	t <sub>RPC</sub>	5	—	5	—	5	—	ns	11
RAS to CAS Set-up Time (CAS before RAS)	t <sub>CSR</sub>	5	—	5	—	5	—	ns	11
RAS to CAS Hold Time (CAS before RAS)	t <sub>CHR</sub>	10	—	15	—	15	—	ns	12
CAS Precharge Time (Refresh Counter Test)	t <sub>CPT</sub>	20	—	30	—	40	—	ns	14

- Notes:
1. A start-up delay of 200  $\mu$ s is required after power-up, followed by a minimum of eight initialization cycles ( $\overline{\text{RAS}}$ -only refresh or  $\overline{\text{CAS}}$  before  $\overline{\text{RAS}}$  refresh) before proper device operation is achieved.
  2. The AC characteristics assume  $t_T = 5$  ns.
  3.  $V_{IH}$  (Min.) and  $V_{IL}$  (Max.) are reference levels for measuring input timing signals. Transition times ( $t_T$ ) are measured between  $V_{IH}$  and  $V_{IL}$ .
  4. This parameter is measured with a load circuit equivalent to 2 TTL loads and 100 pF.
  5. Operation within the  $t_{RCD}$  (Max.) limit ensures that  $t_{RAC}$  (Max.) can be met.  $t_{RCD}$  (Max.) is specified as a reference point only. If  $t_{RCD}$  is greater than the specified  $t_{RCD}$  (Max.) limit, access time is controlled by  $t_{CAC}$ .
  6. Operation within the  $t_{RAD}$  (Max.) limit ensures that  $t_{RAC}$  (Max.) can be met.  $t_{RAD}$  (Max.) is specified as a reference point only. If  $t_{RAD}$  is greater than the specified  $t_{RAD}$  (Max.) limit, access time is controlled by  $t_{AA}$ .
  7.  $t_{OFF}$  (Max.) and  $t_{OEZ}$  (Max.) define the time at which the output achieves the open circuit condition and are not referenced to output voltage levels.
  8.  $t_{RCH}$  or  $t_{RRH}$  must be satisfied for a read cycle.
  9.  $t_{WCS}$ ,  $t_{CWD}$ ,  $t_{RWD}$ ,  $t_{AWD}$  and  $t_{CPWD}$  are not restrictive operating parameters. They are included in the data sheet as electrical characteristics only. If  $t_{WCS} \geq t_{WCS}$  (Min.), the cycle is an early write cycle and the data out will remain open circuit (high impedance) throughout the entire cycle. If  $t_{CWD} \geq t_{CWD}$  (Min.),  $t_{RWD} \geq t_{RWD}$  (Min.),  $t_{AWD} \geq t_{AWD}$  (Min.) and  $t_{CPWD} \geq t_{CPWD}$  (Min.), the cycle is a read modify write cycle and data out will contain data read from the selected cell; if neither of the above sets of conditions is satisfied, the condition of the data out (at access time) is indeterminate.
  10. These parameters are referenced to  $\overline{\text{UCAS}}$ ,  $\overline{\text{LCAS}}$ , leading edge in an early write cycle, and to  $\overline{\text{WE}}$  leading edge in an  $\overline{\text{OE}}$  control write cycle or a read modify write cycle.
  11. These parameters are determined by the falling edge of  $\overline{\text{UCAS}}$  or  $\overline{\text{LCAS}}$ , whichever is earlier.
  12. These parameters are determined by the rising edge of  $\overline{\text{UCAS}}$  or  $\overline{\text{LCAS}}$ , whichever is later.
  13.  $t_{CWL}$  should be satisfied by both  $\overline{\text{UCAS}}$  or  $\overline{\text{LCAS}}$ .
  14.  $t_{CP}$  and  $t_{CPT}$  are determined by the time both  $\overline{\text{UCAS}}$  or  $\overline{\text{LCAS}}$  are high.

**See ADDENDUM E for AC Timing Waveforms**