



Fast CMOS 3.3V 16-Bit Octal Buffer/Line Drivers

**Product Features:**

- Supports Mixed Signal Mode Operation
  - 5 Volt Input.
  - 5 Volt Output (when connected to a 5 Volt Bus).
  - Can serve as a 5 volt to 3 volt translator.
- Advanced Low Power CMOS Operation.
- Low Standby Current (Low power CMOS, not Bi-CMOS, so output drive transistors do not require bipolar standby current levels). Typical standby power 1 mW.
- Excellent output drive capability: Balanced drives (24 mA sink and source). Compatible with LVC™ class of products.
- Pin and functional compatible: Industry standard double-density pinouts.
- Low ground bounce outputs, hysteresis on all inputs.
- ESD Protection exceeds 2000 volts.
- Packaged in 48-pin plastic TSSOP and SSOP

**Product Description:**

Pericom Semiconductor's PI74FCT series of logic circuits are produced in the Company's advanced 0.8 micron CMOS technology, achieving industry leading speed grades.

The PI74FCT163244 is a 16-bit buffer/line driver designed for applications driving high capacitance loads and low impedance backplanes. This high-speed, low power device offers bus/backplane interface capability and a flow-through organization for ease of board layout. This device is designed with three-state controls to operate in a Quad-Nibble, Dual-Byte, or a single 16-bit word mode.

The PI74FCT163244 can be driven from either 3.3 V or 5.0 V devices allowing this device to be used as a translator in a mixed 3.3/5.0 V system.

All products are available in 48-pin 240 mil wide plastic TSSOP and 300 mil wide plastic SSOP packages.

**Logic Block Diagram**

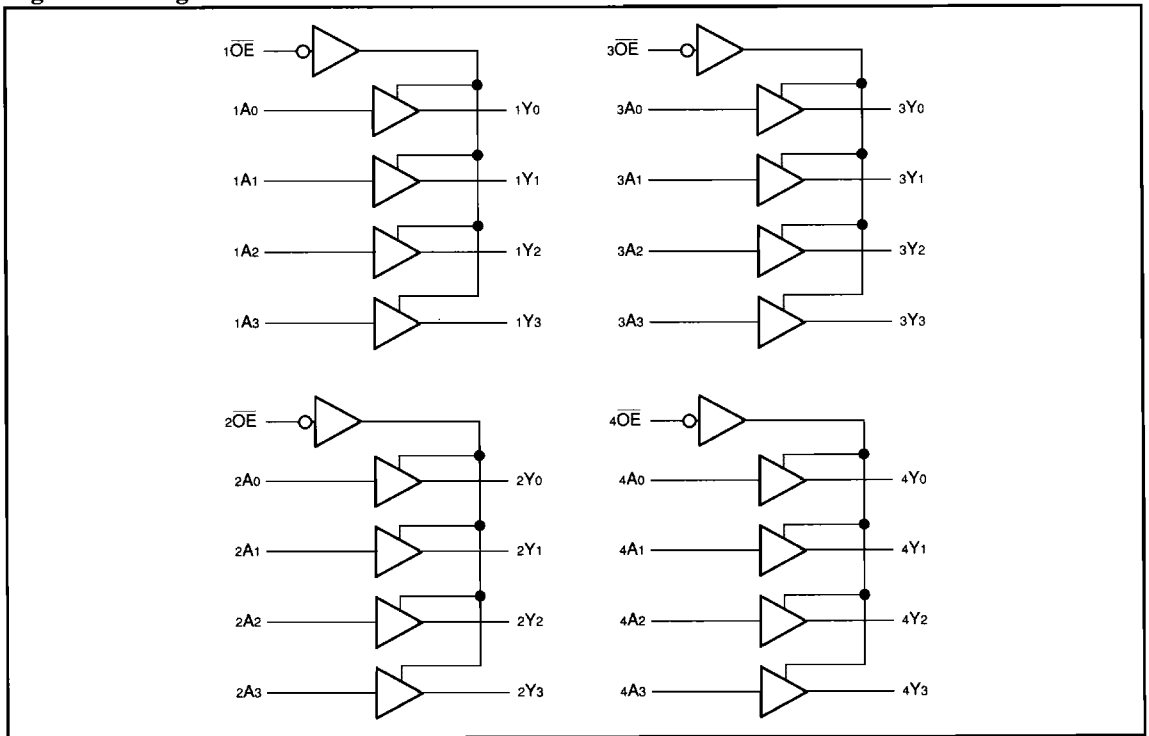

**Product Pin Description**

Pin Name	Description
x $\overline{OE}$	3-State Output Enable Inputs (Active LOW)
xAx	Inputs
xYx	3-State Outputs
GND	Ground
Vcc	Power

**Truth Table**

Inputs <sup>(1)</sup>		Outputs <sup>(1)</sup>
x $\overline{OE}$	xAx	xYx
L	L	L
L	H	H
H	X	Z

**Note:**

- H = High Voltage Level, X = Don't Care, L = Low Voltage Level, Z = High Impedance

**Product Pin Configuration**

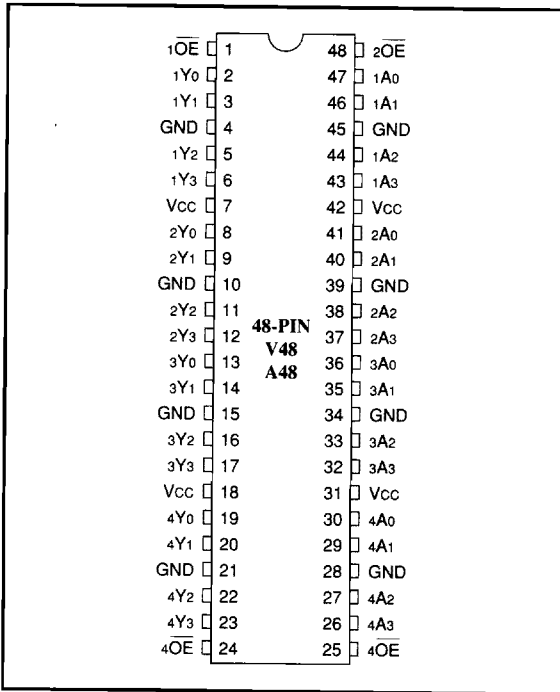

**Capacitance** ( $T_A = 25^\circ\text{C}$ ,  $f = 1\text{ MHz}$ )

Parameters <sup>(1)</sup>	Description	Test Conditions	Typ	Max.	Units
C <sub>IN</sub>	Input Capacitance	V <sub>IN</sub> = 0 V	4.5	6	pF
C <sub>OUT</sub>	Output Capacitance	V <sub>OUT</sub> = 0 V	5.5	8	pF

**Note:**

- This parameter is determined by device characterization but is not production tested.



**Maximum Ratings**

(Above which the useful life may be impaired. For user guidelines, not tested.)

Storage Temperature .....	-55°C to +125°C
Ambient Temperature with Power Applied .....	-40°C to +85°C
Supply Voltage to Ground Potential (Inputs & Vcc Only) .....	-0.5V to +7.0V
Supply Voltage to Ground Potential (Outputs & D/O Only) .....	-0.5V to Vcc
DC Input Voltage .....	-0.5V to +7.0V
DC Output Current .....	120 mA
Power Dissipation .....	1.0W

**Note:**

Stresses greater than those listed under MAXIMUM RATINGS may cause permanent damage to the device. This is a stress rating only and functional operation of the device at these or any other conditions above those indicated in the operational sections of this specification is not implied. Exposure to absolute maximum rating conditions for extended periods may affect reliability.

**DC Electrical Characteristics** (Over the Operating Range, TA = -40°C to +85°C, VCC = 3.3V ± 0.3V)

Parameters	Description	Test Conditions <sup>(1)</sup>		Min.	Typ <sup>(2)</sup>	Max.	Units
VIH	Input HIGH Voltage (Input pins)	Guaranteed Logic HIGH Level		2.2		5.5	V
	Input HIGH Voltage (I/O pins)			2.0		5.5	V
VIL	Input LOW Voltage (Input and I/O pins)	Guaranteed Logic LOW Level		-0.5		0.8	V
IIH	Input HIGH Current (Input pins)	VCC = Max.	VIN = 5.5V			±5	µA
	Input HIGH Current (I/O pins)	VCC = Max.	VIN = VCC			15	µA
IIL	Input LOW Current (Input pins)	VCC = Max.	VIN = GND			±5	µA
	Input LOW Current (I/O pins)	VCC = Max.	VIN = GND			15	µA
IOZH	High Impedance Output Current	VCC = Max.	VOUT = VCC			10	µA
IOZL	(3-State Output pins)	VCC = Max.	VOUT = GND			10	µA
VIK	Clamp Diode Voltage	VCC = Min., IIN = -18 mA				-1.2	V
IODH	Output HIGH Current	VCC = 3.3V, VIN = VIH or VIL, VO = 1.5V <sup>(3)</sup>		-36		-110	mA
IODL	Output LOW Current	VCC = 3.3V, VIN = VIH or VIL, VO = 1.5V <sup>(3)</sup>		50		200	mA
VOH	Output HIGH Voltage	VCC = Min.	IOH = -0.1mA	VCC-0.2			V
		VIN = VIH or VIL	IOH = -8mA	2.4			V
			IOH = -24mA	2.0			V
VOL	Output LOW Voltage	VCC = Min. VIN = VIH or VIL	IOL = 0.1mA			0.2	V
			IOL = 16mA			0.4	V
			IOL = 24mA			0.5	V
IOS	Short Circuit Current <sup>(4)</sup>	VCC = Max. <sup>(3)</sup> , VOUT = GND		-60	-135	-240	mA
IOFF		VCC = 0V, VIN or VOUT = 4.5V				100	µA
VH	Input Hysteresis				150		mV
ICCL	Quiescent Power Supply Current	VCC = Max., VIN = GND or VCC				1.5	mA
ICCH							
IC CZ							

**Notes:**

1. For conditions show as Max. or Min., use appropriate value specified under Electrical Characteristics for the applicable device type.
2. Typical values are at VCC = 3.3, +25°C ambient and maximum loading.
3. Not more than one output should be shorted at one time. Duration of the test should not exceed one second.
4. This parameter is guaranteed but not tested.

Power Supply Characteristics

Parameters	Description	Test Conditions <sup>(1)</sup>		Min.	Typ <sup>(2)</sup>	Max.	Units
ΔIcc	Quiescent Power Supply Current TTL Inputs HIGH	Vcc = Max.	VIN = VCC - 0.6 <sup>(3)</sup>		2.0	30	μA
			VIN = 2.4 V <sup>(3)</sup>		70	500	μA
Iccd	Dynamic Power Supply <sup>(4)</sup>	Vcc = Max., Outputs Open xOE = GND One Bit Toggling 50% Duty Cycle	VIN = VCC VIN = GND		50	75	μA/ MHz
Ic	Total Power Supply Current <sup>(6)</sup>	Vcc = Max., Outputs Open fi = 10 MHz 50% Duty Cycle xOE = GND One Bit Toggling	VIN = VCC - 0.6V VIN = GND		0.6	2.3	mA
			VIN = 2.4 V VIN = GND		0.6	2.5	
		Vcc = Max., Outputs Open fi = 2.5 MHz 50% Duty Cycle xOE = GND 16 Bits Toggling	VIN = VCC - 0.6V VIN = GND		2.1	4.7 <sup>(5)</sup>	
			VIN = 2.4 V VIN = GND		2.6	8.5 <sup>(5)</sup>	

Notes:

- For conditions shown as Max. or Min., use appropriate value specified under Electrical Characteristics for the applicable device.
- Typical values are at Vcc = 3.3 V, +25°C ambient.
- Per TTL driven input (VIN = 3.4 V); all other inputs at Vcc or GND.
- This parameter is not directly testable, but is derived for use in Total Power Supply Calculations.
- Values for these conditions are examples of the Icc formula. These limits are guaranteed but not tested.
- $I_c = I_{\text{QUIESCENT}} + I_{\text{INPUTS}} + I_{\text{DYNAMIC}}$   
 $I_c = I_{\text{CC}} + \Delta I_{\text{CC}} D_H N_T + I_{\text{CCD}} (f_{\text{CP}}/2 + f_i N_i)$   
 $I_{\text{CC}} = \text{Quiescent Current (IcCL, IcCH and IcCZ)}$   
 $\Delta I_{\text{CC}} = \text{Power Supply Current for a TTL High Input}$   
 $D_H = \text{Duty Cycle for TTL Inputs High}$   
 $N_T = \text{Number of TTL Inputs at } D_H$   
 $I_{\text{CCD}} = \text{Dynamic Current Caused by an Input Transition Pair (HLH or LHL)}$   
 $f_{\text{CP}} = \text{Clock Frequency for Register Devices (Zero for Non-Register Devices)}$   
 $N_{\text{CP}} = \text{Number of Clock Inputs at } f_{\text{CP}}$   
 $f_i = \text{Input Frequency}$   
 $N_i = \text{Number of Inputs at } f_i$   
 All currents are in milliamps and all frequencies are in megahertz.

5

Switching Characteristics over Operating Range

Parameters	Description	Conditions <sup>(1)</sup>	FCT163244T		FCT163244AT		Unit
			Com.		Com.		
			Min	Max	Min	Max	
tPLH	Propagation Delay xAX to xYx	Cl. = 50 pF Rl. = 500Ω	1.5	6.5	1.5	4.8	ns
tPHL			1.5	8.0	1.5	6.2	ns
tpZH	Output Enable Time		1.5	7.0	1.5	5.6	ns
tpZL	Output Disable Time						
tpHZ							
tPLZ							
tsk(o)	Output Skew <sup>(3)</sup>			0.5		0.5	ns

Notes:

1. See test circuit and wave forms.
2. Minimum limits are guaranteed but not tested on Propagation Delays.
3. Skew between any two outputs, of the same package, switching in the same direction. This parameter is guaranteed by design.