

3.3V Octal buffer/line driver with 30Ω series termination resistors (3-State)

74LVT2241

FEATURES

- Octal bus interface
- 3-State buffers
- Output capability: +12mA/-12mA
- TTL input and output switching levels
- Input and output interface capability to systems at 5V supply
- Bus-hold data inputs eliminate the need for external pull-up resistors to hold unused inputs
- Power-up 3-State
- Live insertion/extraction permitted
- No bus current loading when output is tied to 5V bus
- Latch-up protection exceeds 500mA per JEDEC Std 17
- ESD protection exceeds 2000V per MIL STD 883 Method 3015 and 200V per Machine Model.
- Outputs include series resistance of 30Ω, making external termination resistors unnecessary.

DESCRIPTION

The 74LVT2241 high-performance BiCMOS device combines low static and dynamic power dissipation with high speed and high output drive.

The 74LVT2241 device is an octal buffer that is ideal for driving bus lines. The device features two Output Enables (1OE, 2OE), each controlling four of the 3-State outputs.

The 74LVT2241 is designed with 30Ω series resistance in both the High and Low states of the output. This design reduces the line noise in applications such as memory address drivers, clock drivers and bus receivers/transmitters.

QUICK REFERENCE DATA

SYMBOL	PARAMETER	CONDITIONS $T_{amb} = 25^{\circ}\text{C}; \text{GND} = 0\text{V}$	TYPICAL	UNIT
t_{PLH} t_{PHL}	Propagation delay nA_x to nY_x	$C_L = 50\text{pF};$ $V_{CC} = 3.3\text{V}$	3.0 3.3	ns
C_{IN}	Input capacitance	$V_I = 0\text{V}$ or 3.0V	4	pF
C_{OUT}	Output capacitance	Outputs disabled; $V_O = 0\text{V}$ or 3.0V	8	pF
I_{CCZ}	Total supply current	Outputs disabled; $V_{CC} = 3.6\text{V}$	0.12	mA

ORDERING INFORMATION

PACKAGES	TEMPERATURE RANGE	OUTSIDE NORTH AMERICA	NORTH AMERICA	DWG NUMBER
20-Pin Plastic SOL	-40°C to +85°C	74LVT2241 D	74LVT2241 D	SOT163-1
20-Pin Plastic SSOP Type II	-40°C to +85°C	74LVT2241 DB	74LVT2241 DB	SOT339-1
20-Pin Plastic TSSOP Type I	-40°C to +85°C	74LVT2241 PW	7LVT2241PW DH	SOT360-1

PIN CONFIGURATION

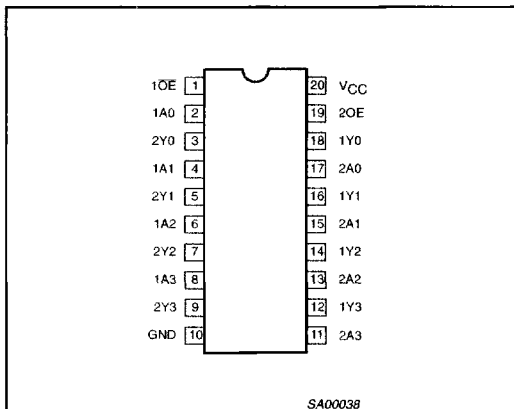

PIN DESCRIPTION

PIN NUMBER	SYMBOL	NAME AND FUNCTION
2, 4, 6, 8	1A0 – 1A3	Data inputs
17, 15, 13, 11	2A0 – 2A3	Data inputs
18, 16, 14, 12	1Y0 – 1Y3	Data outputs
3, 5, 7, 9	2Y0 – 2Y3	Data outputs
1, 19	1OE, 2OE	Output enables
10	GND	Ground (0V)
20	V_{CC}	Positive supply voltage

3.3V Octal buffer/line driver with 30Ω series termination resistors (3-State)

74LVT2241

LOGIC SYMBOL (IEEE/IEC)

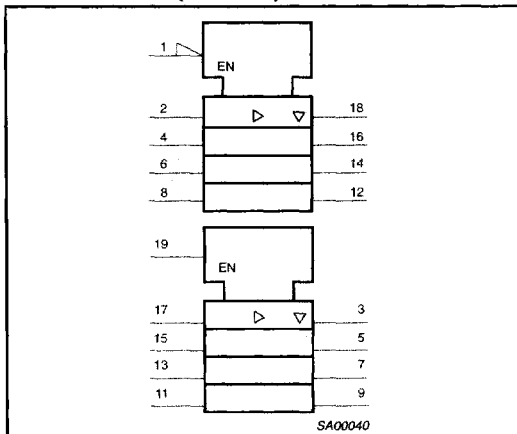

LOGIC SYMBOL

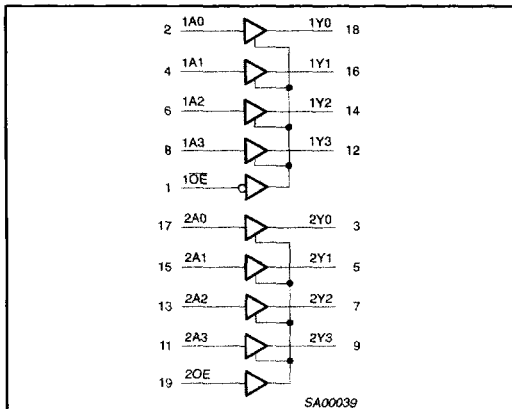

SCHEMATIC OF EACH OUTPUT

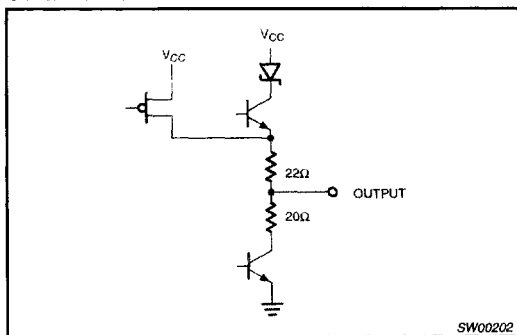

FUNCTION TABLE

INPUTS				OUTPUTS	
1OE	1An	2OE	2An	1Yn	2Yn
L	L	H	L	L	L
L	H	H	H	H	H
H	X	L	X	Z	Z

H = High voltage level
 L = Low voltage level
 X = Don't care
 Z = High impedance "off" state

ABSOLUTE MAXIMUM RATINGS^{1, 2}

SYMBOL	PARAMETER	CONDITIONS	RATING	UNIT
V _{CC}	DC supply voltage		-0.5 to +4.6	V
V _I	DC input voltage ³		-0.5 to +7.0	V
V _{OUT}	DC output voltage ³	Output in Off or High state	-0.5 to +7.0	V
I _{OUT}	DC output current	Output in Low state	128	mA
		Output in High state	-64	
I _{IK}	DC input diode current	V _I < 0	-50	mA
I _{OK}	DC output diode current	V _O < 0	-50	mA
T _{stg}	Storage temperature range		-65 to 150	°C

NOTES:

- Stresses beyond those listed may cause permanent damage to the device. These are stress ratings only and functional operation of the device at these or any other conditions beyond those indicated under "recommended operating conditions" is not implied. Exposure to absolute-maximum-rated conditions for extended periods may affect device reliability.
- The performance capability of a high-performance integrated circuit in conjunction with its thermal environment can create junction temperatures which are detrimental to reliability. The maximum junction temperature of this integrated circuit should not exceed 150°C.
- The input and output negative voltage ratings may be exceeded if the input and output clamp current ratings are observed.

3.3V Octal buffer/line driver with 30Ω series termination resistors (3-State)

74LVT2241

RECOMMENDED OPERATING CONDITIONS

SYMBOL	PARAMETER	LIMITS		UNIT
		MIN	MAX	
V _{CC}	DC supply voltage	2.7	3.6	V
V _I	Input voltage	0	5.5	V
V _{IH}	High-level input voltage	2.0		V
V _{IL}	Low-level input voltage		0.8	V
I _{OH}	High-level output current		-12	mA
I _{OL}	Low-level output current		12	mA
Δt/Δv	Input transition rise or fall rate; outputs enabled		10	ns/V
T _{amb}	Operating free-air temperature range	-40	+85	°C

DC ELECTRICAL CHARACTERISTICS

SYMBOL	PARAMETER	TEST CONDITIONS	LIMITS			UNIT	
			T _{amb} = -40°C to +85°C				
			MIN	TYP ¹	MAX		
V _{IK}	Input clamp voltage	V _{CC} = 2.7V; I _I = -18mA		0.9	-1.2	V	
V _{OH}	High-level output voltage	V _{CC} = 3V; I _{OH} = -12mA	2	2.2		V	
V _{OL}	Low-level output voltage	V _{CC} = 3V; I _{OL} = 12mA			0.8	V	
I _I	Input leakage current	V _{CC} = 0 or 3.6V; V _I = 5.5V		1	10	μA	
		V _{CC} = 3.6V; V _I = V _{CC} or GND	Control pins		±0.1		
		V _{CC} = 3.6V; V _I = V _{CC}	Data pins ⁴		0.1		1
		V _{CC} = 3.6V; V _I = 0			-1		-5
I _{OFF}	Output off current	V _{CC} = 0V; V _I or V _O = 0 to 4.5V		1	±100	μA	
I _{HOLD}	Bus hold current A inputs	V _{CC} = 3.0V; V _I = 0.8V	A inputs	75	150	μA	
		V _{CC} = 3.0V; V _I = 2.0V		-75	-150		
I _{EX}	Current into an output in the High state when V _O > V _{CC}	V _O = 5.5V; V _{CC} = 3.0V		60	125	μA	
I _{PU/PD}	Power up/down 3-State output current ³	V _{CC} = ≤ 1.2V; V _O = 0.5V to V _{CC} ; V _I = GND or V _{CC} ; OE/OE = Don't care		±1	±100	μA	
I _{OZH}	3-State output High current	V _{CC} = 3.6V; V _O = 3.0V		1	5	μA	
I _{OZL}	3-State output Low current	V _{CC} = 3.6V; V _O = 0.5V		-1	-5	μA	
I _{CC}	Quiescent supply current	V _{CC} = 3.6V; Outputs High, V _I = GND or V _{CC} , I _O = 0		0.12	0.19	mA	
		V _{CC} = 3.6V; Outputs Low, V _I = GND or V _{CC} , I _O = 0		3	12		
		V _{CC} = 3.6V; Outputs Disabled; V _I = GND or V _{CC} , I _O = 0 ⁵		0.12	0.19		
ΔI _{CC}	Additional supply current per input pin ²	V _{CC} = 3.0 to 3.6V; One input at V _{CC} -0.6V; Other inputs at V _{CC} or GND		0.1	0.25	mA	

NOTES:

- All typical values are at T_{amb} = 25°C.
- This is the increase in supply current for each input at V_{CC} -0.6V.
- This parameter is valid for any V_{CC} between 0V and 1.2V with a transition time of up to 10msec. From V_{CC} = 1.2V to V_{CC} = 3.3V ± 10% a transition time of 100μsec is permitted. This parameter is valid for T_{amb} = 25°C only.
- Unused pins at V_{CC} or GND
- I_{CCZ} is measured with outputs pulled to V_{CC} or GND.

3.3V Octal buffer/line driver with 30Ω series termination resistors (3-State)

74LVT2241

AC CHARACTERISTICS

GND = 0V; $t_{\text{R}} = t_{\text{F}} = 2.5\text{ns}$; $C_{\text{L}} = 50\text{pF}$; $R_{\text{L}} = 500\Omega$; $T_{\text{amb}} = -40^{\circ}\text{C}$ to $+85^{\circ}\text{C}$.

SYMBOL	PARAMETER	WAVEFORM	LIMITS				UNIT
			$T_{\text{amb}} = -40^{\circ}\text{C}$ to $+85^{\circ}\text{C}$ $V_{\text{CC}} = +3.3\text{V} \pm 0.3\text{V}$			$V_{\text{CC}} = 2.7\text{V}$	
			MIN	TYP ¹	MAX	MAX	
t_{PLH} t_{PHL}	Propagation delay $n\text{Ax}$ to $n\text{Yx}$	1	1 1	3.0 3.3	4.2 4.3	5.0 4.7	ns
t_{PZH} t_{PZL}	Output enable time to High and Low level, 1OE to 1Y_n	2	1 1	4.4 4.3	6.2 5.9	8.5 6.8	ns
t_{PHZ} t_{PLZ}	Output disable time from High and Low level, 1OE to 1Y_n	2	1 1.6	3.4 3.2	5.0 4.5	5.2 4.5	ns
t_{PZH} t_{PZL}	Output enable time to High and Low level, 2OE to 2Y_n	2	1 1	4.4 4.1	6.2 5.5	7.9 6.2	ns
t_{PHZ} t_{PLZ}	Output disable time from High and Low level, 2OE to 2Y_n	2	1 1	3.9 3.8	5.7 5.1	6.4 5.8	ns

NOTE:

1. All typical values are at $V_{\text{CC}} = 3.3\text{V}$ and $T_{\text{amb}} = 25^{\circ}\text{C}$.

AC WAVEFORMS

$V_{\text{M}} = 1.5\text{V}$, $V_{\text{IN}} = \text{GND}$ to 3.0V

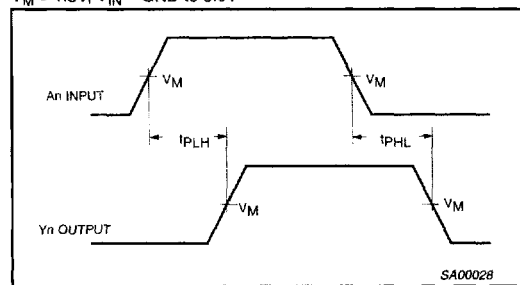

Waveform 1. Waveforms Showing the Input (An) to Output (Yn) Propagation Delays

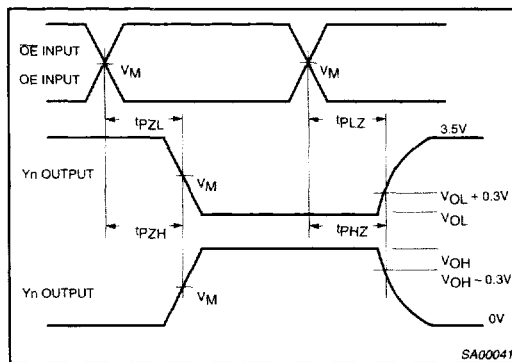

Waveform 2. Waveforms Showing the 3-State Output Enable and Disable Times

3.3V Octal buffer/line driver with 30Ω series termination resistors (3-State)

74LVT2241

TEST CIRCUIT AND WAVEFORMS

Test Circuit for 3-State Outputs

$V_M = 1.5V$
Input Pulse Definition

SWITCH POSITION

TEST	SWITCH
t_{PLH}/t_{PHL}	Open
t_{PLZ}/t_{PZL}	6V
t_{PHZ}/t_{PZH}	GND

DEFINITIONS

R_L = Load resistor; see AC CHARACTERISTICS for value.

C_L = Load capacitance includes jig and probe capacitance; see AC CHARACTERISTICS for value.

R_T = Termination resistance should be equal to Z_{OUT} of pulse generators.

FAMILY	INPUT PULSE REQUIREMENTS				
	Amplitude	Rep. Rate	t_w	t_R	t_F
74LVT	2.7V	≤ 10MHz	500ns	≤ 2.5ns	≤ 2.5ns

SV00092