

## Quad Low Power Operational Amplifiers

The MC3503 is a low cost, quad operational amplifier with true differential inputs. The device has electrical characteristics similar to the popular MC1741. However, the MC3503 has several distinct advantages over standard operational amplifier types in single supply applications. The quad amplifier can operate at supply voltages as low as 3.0 V or as high as 36 V with quiescent currents about one third of those associated with the MC1741 (on a per amplifier basis). The common mode input range includes the negative supply, thereby eliminating the necessity for external biasing components in many applications. The output voltage range also includes the negative power supply voltage.

- Short Circuit Protected Outputs
- Class AB Output Stage for Minimal Crossover Distortion
- True Differential Input Stage
- Single Supply Operation: 3.0 V to 36 V
- Split Supply Operation:  $\pm 1.5$  V to  $\pm 18$  V
- Low Input Bias Currents: 500 nA Max
- Four Amplifiers Per Package
- Internally Compensated
- Similar Performance to Popular MC1741
- Industry Standard Pinouts
- ESD Diodes Added for Increased Ruggedness

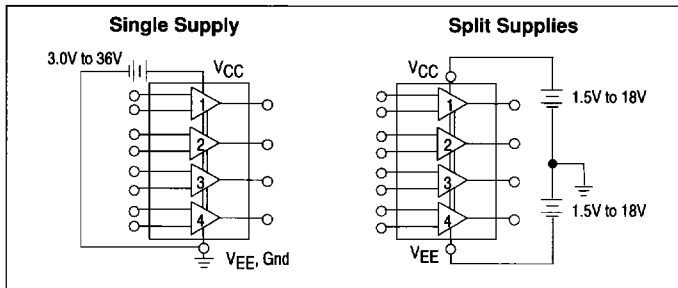

### MAXIMUM RATINGS

Rating	Symbol	Value	Unit
Power Supply Voltages Single Supply Split Supplies	$V_{CC}$ $V_{CC}, V_{EE}$	36 $\pm 18$	Vdc
Input Differential Voltage Range (Note 1)	$V_{IDR}$	$\pm 36$	Vdc
Input Common Mode Voltage Range (Notes 1, 2)	$V_{ICR}$	$\pm 18$	Vdc
Storage Temperature Range Ceramic Package Plastic Package	$T_{stg}$	-65 to +150 -55 to +125	$^{\circ}C$
Operating Ambient Temperature Range MC3303 MC3403 MC3503	$T_A$	0 to +70 -40 to +85 -55 to +125	$^{\circ}C$
Junction Temperature Ceramic Package Plastic Package	$T_J$	175 150	$^{\circ}C$

NOTES: 1. Split power supplies.  
2. For supply voltages less than  $\pm 18$ V, the absolute maximum input voltage is equal to the supply voltage.

**MC3403  
MC3503  
MC3303**

### QUAD DIFFERENTIAL INPUT OPERATIONAL AMPLIFIERS

**SILICON MONOLITH INTEGRATED CIRCUIT**

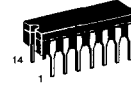

**L SUFFIX  
CERAMIC PACKAGE  
CASE 632**



**D SUFFIX  
PLASTIC PACKAGE  
CASE 751A  
(SO-14)**



**P SUFFIX  
PLASTIC PACKAGE  
CASE 646  
(MC3403 and MC3303 Only)**

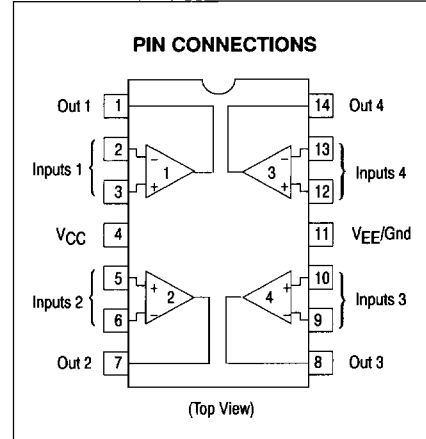

### ORDERING INFORMATION

Device	Temperature Range	Package
MC3303D	-40 $^{\circ}$ to +85 $^{\circ}C$	SO-14
MC3303L		Ceramic DIP
MC3303P		Plastic DIP
MC3403D	0 $^{\circ}$ to +70 $^{\circ}C$	SO-14
MC3403L		Ceramic DIP
MC3403P		Plastic DIP
MC3503L	-55 $^{\circ}$ to +125 $^{\circ}C$	Ceramic DIP

# MC3403, MC3503, MC3303

**ELECTRICAL CHARACTERISTICS** ( $V_{CC} = +15\text{ V}$ ,  $V_{EE} = -15\text{ V}$  for MC3503, MC3403;  $V_{CC} = +14\text{ V}$ ,  $V_{EE} = \text{Gnd}$  for MC3303  
 $T_A = 25^\circ\text{C}$ , unless otherwise noted.)

**2**

Characteristics	Symbol	MC3503			MC3403			MC3303			Unit
		Min	Typ	Max	Min	Typ	Max	Min	Typ	Max	
Input Offset Voltage $T_A = T_{\text{high}} \text{ to } T_{\text{low}}$ (Note 1)	$V_{IO}$	—	2.0	5.0	—	2.0	10	—	2.0	8.0	mV
Input Offset Current $T_A = T_{\text{high}} \text{ to } T_{\text{low}}$	$I_{IO}$	—	30	50	—	30	50	—	30	75	nA
Input Bias Current $T_A = T_{\text{high}} \text{ to } T_{\text{low}}$	$I_{IB}$	—	-200	-500	—	-200	-500	—	-200	-500	nA
Output Impedance $f = 20\text{ Hz}$	$z_o$	—	75	—	—	75	—	—	75	—	$\Omega$
Input Impedance $f = 20\text{ Hz}$	$z_i$	0.3	1.0	—	0.3	1.0	—	0.3	1.0	—	M $\Omega$
Output Voltage Range $R_L = 10\text{ k}\Omega$ $R_L = 2.0\text{ k}\Omega$ $R_L = 2.0\text{ k}\Omega$ , $T_A = T_{\text{high}} \text{ to } T_{\text{low}}$	$V_O$	$\pm 12$ $\pm 10$ $\pm 10$	$\pm 13.5$ $\pm 13$ —	— — —	$\pm 12$ $\pm 10$ $\pm 10$	$\pm 13.5$ $\pm 13$ —	— — —	$\pm 12$ $\pm 10$ $\pm 10$	$\pm 12.5$ $\pm 12$ —	— — —	V
Input Common Mode Voltage Range	$V_{ICR}$	+13 V - $V_{EE}$	+13.5 V - $V_{EE}$	—	+13 V - $V_{EE}$	+13 V - $V_{EE}$	—	+12 V - $V_{EE}$	+12.5 V - $V_{EE}$	—	V
Common Mode Rejection $R_S \leq 10\text{ k}\Omega$	CMR	—	90	—	—	90	—	70	90	—	dB
Power Supply Current ( $V_O = 0$ ) $R_L = \infty$	$I_{CC}^{V_{EE}}$	—	2.8	4.0	—	2.8	7.0	—	2.8	7.0	mA
Individual Output Short-Circuit Current (2)	$I_{SC}$	$\pm 10$	$\pm 30$	$\pm 45$	$\pm 10$	$\pm 20$	$\pm 45$	$\pm 10$	$\pm 30$	$\pm 45$	mA
Positive Power Supply Rejection Ratio	PSRR+	—	30	150	—	30	150	—	30	150	$\mu\text{V/V}$
Negative Power Supply Rejection Ratio	PSRR-	—	30	150	—	30	150	—	30	150	$\mu\text{V/V}$
Average Temperature Coefficient of Input Offset Current $T_A = T_{\text{high}} \text{ to } T_{\text{low}}$	$\Delta I_{IO}/\Delta T$	—	50	—	—	50	—	—	50	—	$\mu\text{A}/^\circ\text{C}$
Average Temperature Coefficient of Input Offset Voltage $T_A = T_{\text{high}} \text{ to } T_{\text{low}}$	$\Delta V_{IO}/\Delta T$	—	10	—	—	10	—	—	10	—	$\mu\text{V}/^\circ\text{C}$
Power Bandwidth $A_V = 1$ , $R_L = 10\text{ k}\Omega$ , $V_O = 20\text{ V(p-p)}$ , THD = 5%	BWp	—	9.0	—	—	9.0	—	—	9.0	—	kHz
Small-Signal Bandwidth $A_V = 1$ , $R_L = 10\text{ k}\Omega$ , $V_O = 50\text{ mV}$	BW	—	1.0	—	—	1.0	—	—	1.0	—	MHz
Slew Rate $A_V = 1$ , $V_i = -10\text{ V to } +10\text{ V}$	SR	—	0.6	—	—	0.6	—	—	0.6	—	V/ $\mu\text{s}$
Rise Time $A_V = 1$ , $R_L = 10\text{ k}\Omega$ , $V_O = 50\text{ mV}$	$t_{RLH}$	—	0.35	—	—	0.35	—	—	0.35	—	$\mu\text{s}$
Fall Time $A_V = 1$ , $R_L = 10\text{ k}\Omega$ , $V_O = 50\text{ mV}$	$t_{FLH}$	—	0.35	—	—	0.35	—	—	0.35	—	$\mu\text{s}$
Overshoot $A_V = 1$ , $R_L = 10\text{ k}\Omega$ , $V_O = 50\text{ mV}$	OS	—	20	—	—	20	—	—	20	—	%
Phase Margin $A_V = 1$ , $R_L = 2.0\text{ k}\Omega$ , $V_O = 200\text{ pF}$	$\phi_m$	—	60	—	—	60	—	—	60	—	Degrees
Crossover Distortion ( $V_{in} = 30\text{ mVp-p}$ , $V_{out} = 2.0\text{ Vp-p}$ , $f = 10\text{ kHz}$ )	—	—	1.0	—	—	1.0	—	—	1.0	—	%

NOTE: 1.  $T_{\text{high}} = 125^\circ\text{C}$  for MC3503,  $70^\circ\text{C}$  for MC3403,  $85^\circ\text{C}$  for MC3303  
 $T_{\text{low}} = -55^\circ\text{C}$  for MC3503,  $0^\circ\text{C}$  for MC3403,  $-40^\circ\text{C}$  for MC3303

**ELECTRICAL CHARACTERISTICS** ( $V_{CC} = 5.0\text{ V}$ ,  $V_{EE} = \text{Gnd}$ ,  $T_A = 25^\circ\text{C}$ , unless otherwise noted.)

Characteristics	Symbol	MC3503			MC3403			MC3303			Unit
		Min	Typ	Max	Min	Typ	Max	Min	Typ	Max	
Input Offset Voltage	$V_{IO}$	—	2.0	5.0	—	2.0	10	—	—	10	mV
Input Offset Current	$I_{IO}$	—	30	50	—	30	50	—	—	75	nA
Input Bias Current	$I_{IB}$	—	-200	-500	—	-200	-500	—	—	-500	nA
Large Signal Open-Loop Voltage Gain $R_L = 2.0\text{ k}\Omega$	$A_{VOL}$	10	200	—	10	200	—	10	200	—	V/mV
Power Supply Rejection Ratio	PSRR	—	—	150	—	—	150	—	—	150	$\mu\text{V/V}$
Output Voltage Range (3) $R_L = 10\text{ k}\Omega$ , $V_{CC} = 5.0\text{ V}$ $R_L = 10\text{ k}\Omega$ , $5.0 \leq V_{CC} \leq 30\text{ V}$	$V_{OR}$	3.3 $V_{CC}-2.0$	3.5 $V_{CC}-1.7$	—	3.3 $V_{CC}-2.0$	3.5 $V_{CC}-1.7$	—	3.3 $V_{CC}-2.0$	3.5 $V_{CC}-1.7$	—	Vp-p
Power Supply Current	$I_{CC}$	—	2.5	4.0	—	2.5	7.0	—	2.5	7.0	mA
Channel Separation $f = 1.0\text{ kHz to } 20\text{ kHz}$ (Input Referenced)	CS	—	-120	—	—	-120	—	—	-120	—	dB

NOTES: 2. Not to exceed maximum package power dissipation.  
3. Output will swing to ground with a  $10\text{ k}\Omega$  pull down resistor.

# MC3403, MC3503, MC3303

## Representative Circuit Schematic

(1/4 of Circuit Shown)

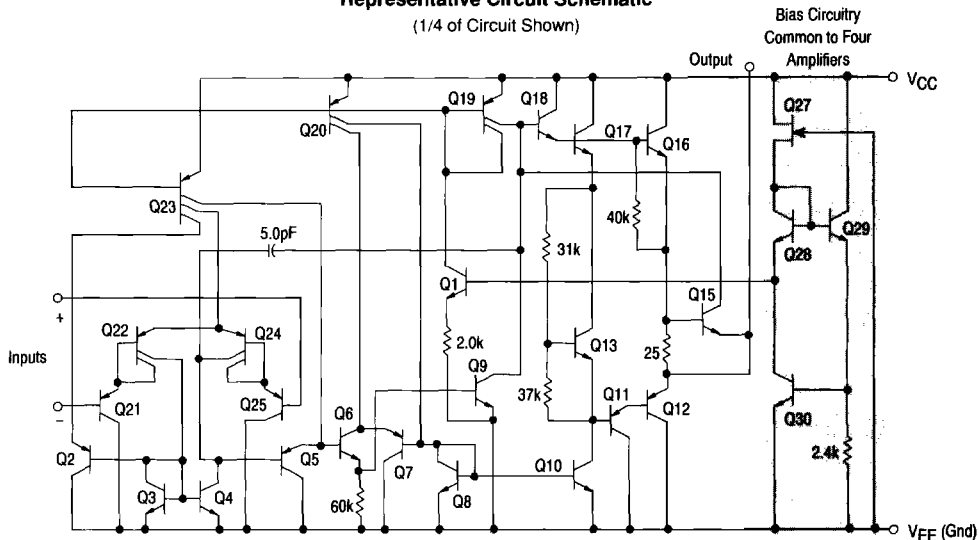

### CIRCUIT DESCRIPTION

#### Inverter Pulse Response

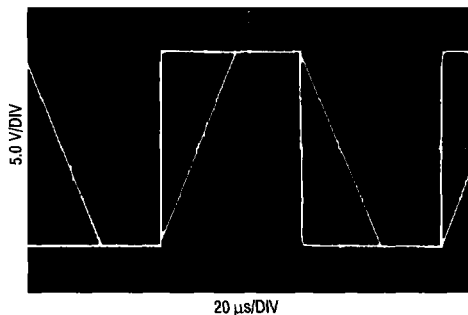

The MC3503/3403/3303 is made using four internally compensated, two-stage operational amplifiers. The first stage of each consists of differential input device Q24 and Q22 with input buffer transistors Q25 and Q21 and the differential

to single ended converter Q3 and Q4. The first stage performs not only the first stage gain function but also performs the level shifting and transconductance reduction functions. By reducing the transconductance a smaller compensation capacitor (only 5.0 pF) can be employed, thus saving chip area. The transconductance reduction is accomplished by splitting the collectors of Q24 and Q22. Another feature of this input stage is that the input common mode range can include the negative supply or ground, in single supply operation, without saturating either the input devices or the differential to single-ended converter. The second stage consists of a standard current source load amplifier stage.

The output stage is unique because it allows the output to swing to ground in single supply operation and yet does not exhibit any crossover distortion in split supply operation. This is possible because Class AB operation is utilized.

Each amplifier is biased from an internal voltage regulator which has a low temperature coefficient thus giving each amplifier good temperature characteristics as well as excellent power supply rejection.

Figure 1. Sine Wave Response

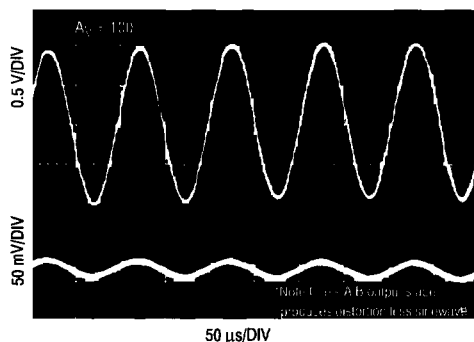
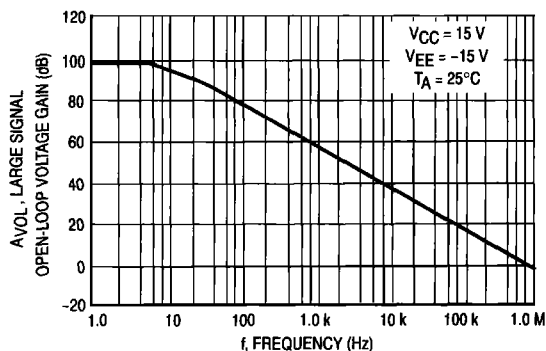

Figure 2. Open-Loop Frequency Response



# MC3403, MC3503, MC3303

Figure 3. Power Bandwidth

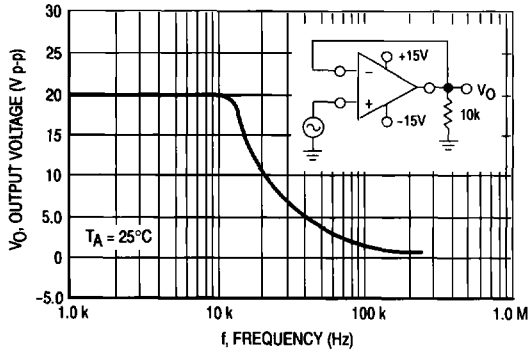

Figure 4. Output Swing versus Supply Voltage

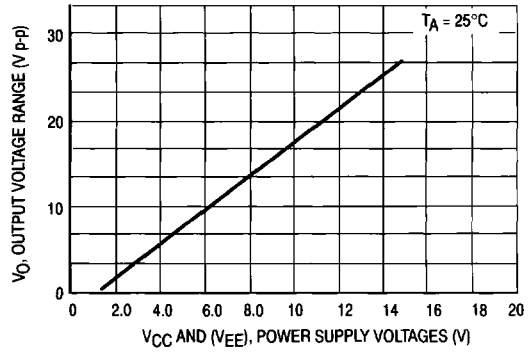

Figure 5. Input Bias Current versus Temperature

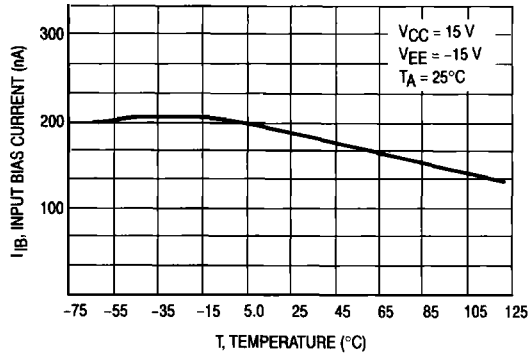

Figure 6. Input Bias Current versus Supply Voltage

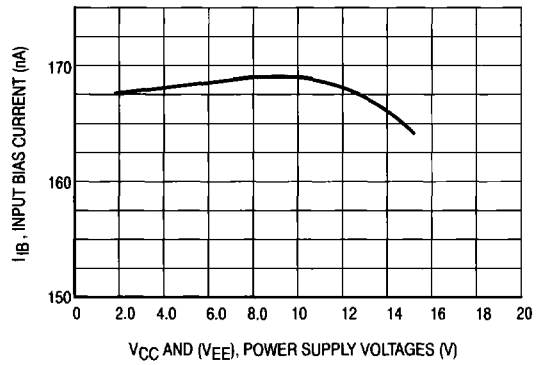

Figure 7. Voltage Reference

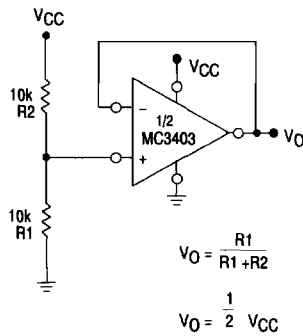
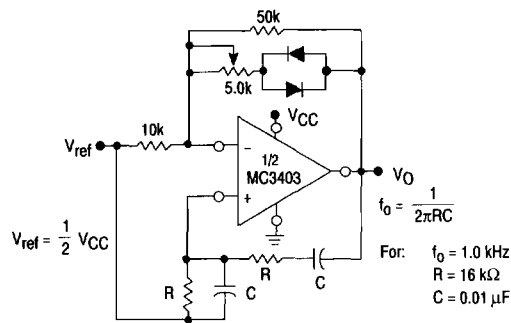

Figure 8. Wien Bridge Oscillator



# MC3403, MC3503, MC3303

2

Figure 9. High Impedance Differential Amplifier

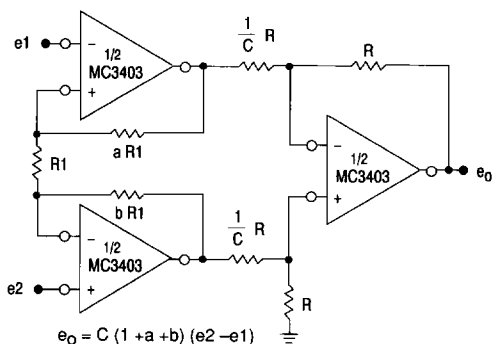

Figure 10. Comparator with Hysteresis

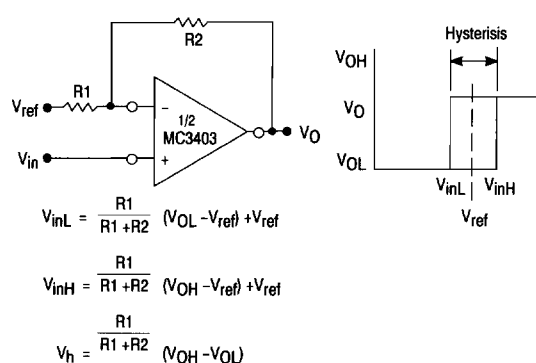

Figure 11. Bi-Quad Filter

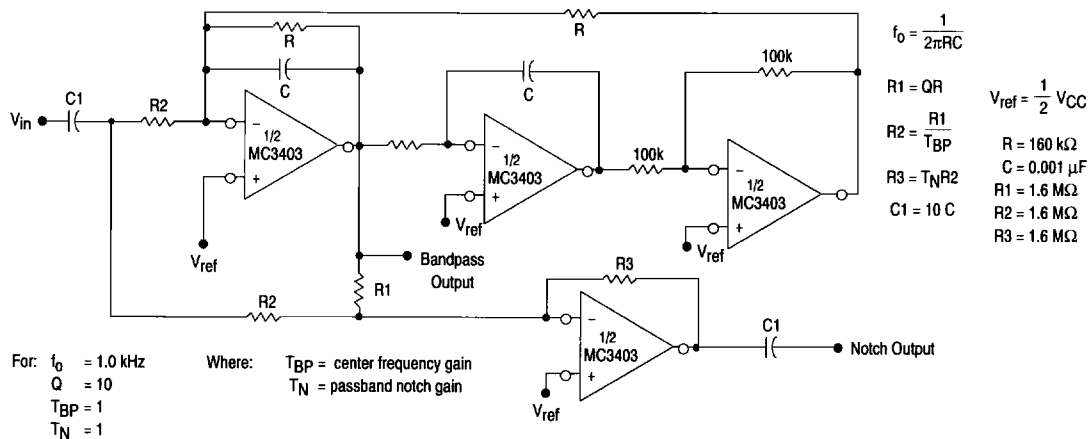

Figure 12. Function Generator

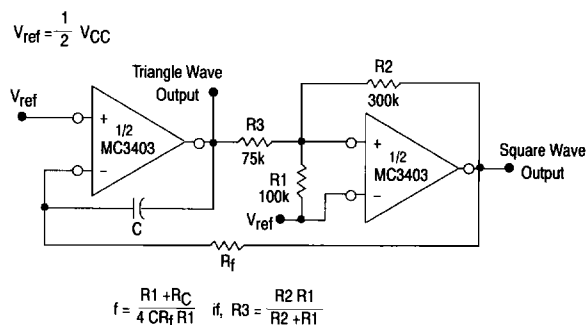

Figure 13. Multiple Feedback Bandpass Filter

