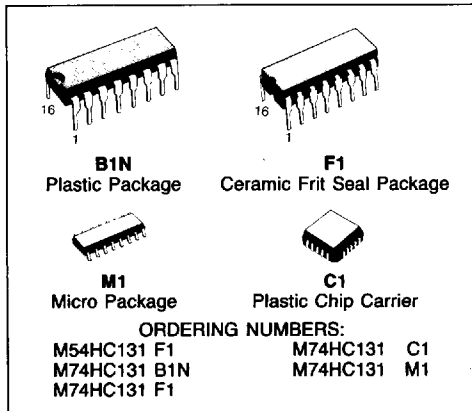

3 TO 8 LINE DECODER/LATCH

- **LOW POWER DISSIPATION**
 $I_{CC} = 4 \mu\text{A (MAX.)}$ at $T_A = 25^\circ\text{C}$
- **HIGH NOISE IMMUNITY**
 $V_{NIH} = V_{NIL} = 28\% V_{CC}$ (MIN.)
- **OUTPUT DRIVE CAPABILITY**
 10 LSTTL LOADS
- **SYMMETRICAL OUTPUT IMPEDANCE**
 $|I_{OH}| = I_{OL} = 4 \text{ mA (MIN.)}$
- **BALANCED PROPAGATION DELAYS**
 $t_{PLH} = t_{PHL}$
- **WIDE OPERATING VOLTAGE RANGE**
 V_{CC} (OPR) = 2V to 6V
- **PIN AND FUNCTION COMPATIBLE**
 WITH 54/74LS131

**DESCRIPTION**

The M54/74HC131 is a high speed CMOS 3 TO 8 LINE DECODER/LATCH fabricated in silicon gate C²MOS technology.

It has the same high speed performance of LSTTL combined with true CMOS low power consumption. This device is a DECODER/LATCH capable of selecting arbitrarily one of eight outputs by three binary inputs A, B, and C, in this case, the selected output is at logic "low".

Also, when ENABLE input G1 is set low or ENABLE input G2 is set high, selection is inhibited regardless of other input signals and all the outputs are at high. All inputs are equipped with protection circuits against static discharge and transient excess voltage.

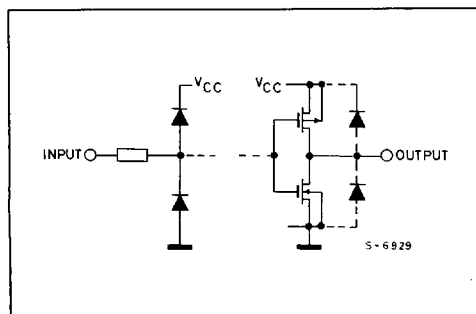
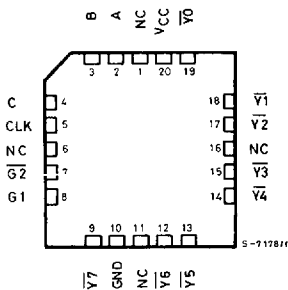
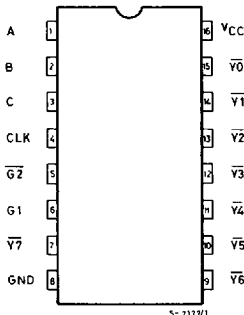
INPUT AND OUTPUT EQUIVALENT CIRCUIT**PIN CONNECTIONS (top view)**

NC =
No Internal
Connection

S G S-THOMSON

TRUTH TABLE

INPUTS						OUTPUTS							
ENABLE			SELECT										
CLK	G1	$\overline{G2}$	C	B	A	Y0	Y1	Y2	Y3	Y4	Y5	Y6	Y7
X	X	H	X	X	X	H	H	H	H	H	H	H	H
X	L	X	X	X	X	H	H	H	H	H	H	H	H
	H	L	L	L	L	L	H	H	H	H	H	H	H
	H	L	L	L	H	H	L	H	H	H	H	H	H
	H	L	L	H	L	H	H	L	H	H	H	H	H
	H	L	L	H	H	H	H	L	H	H	H	H	H
	H	L	H	L	L	H	H	H	H	L	H	H	H
	H	L	H	L	H	H	H	H	H	H	L	H	H
	H	L	H	H	L	H	H	H	H	H	H	L	H
	H	L	H	H	H	H	H	H	H	H	H	H	L
L	H	L	X	X	X	Outputs corresponding to stored address L: all others H							

ABSOLUTE MAXIMUM RATINGS

Symbol	Parameter	Value	Unit
V_{CC}	Supply Voltage	-0.5 to 7	V
V_I	DC Input Voltage	-0.5 to $V_{CC} + 0.5$	V
V_O	DC Output Voltage	-0.5 to $V_{CC} + 0.5$	V
I_{IK}	DC Input Diode Current	± 20	mA
I_{OK}	DC Output Diode Current	± 20	mA
I_O	DC Output Source Sink Current Per Output Pin	± 25	mA
I_{CC} or I_{GND}	DC V_{CC} or Ground Current	± 50	mA
P_D	Power Dissipation	500 (*)	mW
T_{stg}	Storage Temperature	-65 to 150	$^{\circ}C$

Absolute Maximum Ratings are those values beyond which damage to the device may occur. Functional operation under these condition is not implied.

(*) 500 mW: $\cong 65^{\circ}C$ derate to 300 mW by 10 mW/ $^{\circ}C$: $65^{\circ}C$ to $85^{\circ}C$

RECOMMENDED OPERATING CONDITIONS

Symbol	Parameter	Value	Unit
V_{CC}	Supply Voltage	2 to 6	V
V_I	Input Voltage	0 to V_{CC}	V
V_O	Output Voltage	0 to V_{CC}	V
T_A	Operating Temperature	74HC Series 54HC Series	$^{\circ}C$
		- 40 to 85 - 55 to 125	
t_r, t_f	Input Rise and Fall Time	$V_{CC} \begin{cases} 2 V & 0 \text{ to } 1000 \\ 4.5V & 0 \text{ to } 500 \\ 6 V & 0 \text{ to } 400 \end{cases}$	ns

BLOCK DIAGRAM

S G S-THOMSON

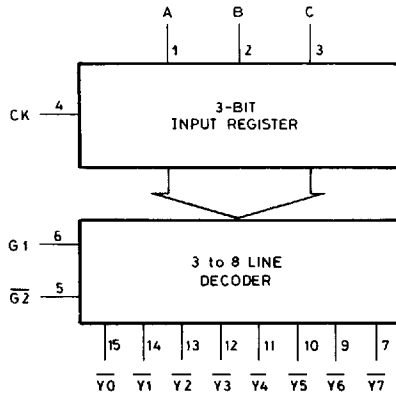

5-9917

V_{CC} = 16
GND = 8

LOGIC DIAGRAM

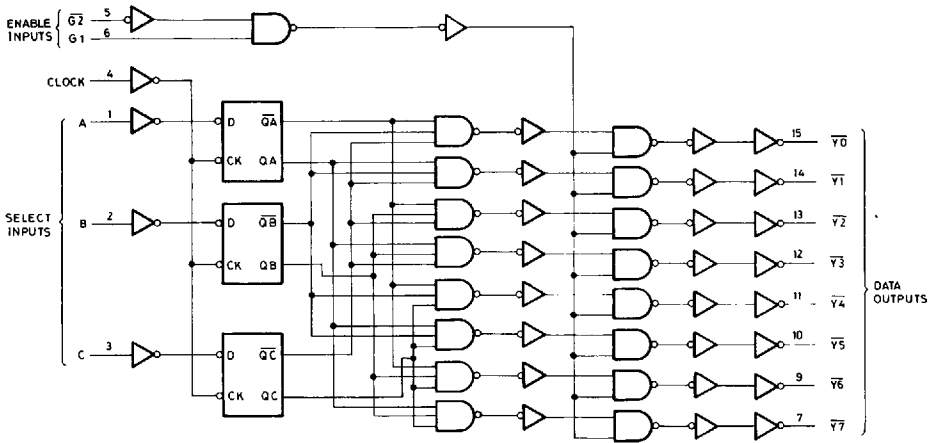

5-9918 / 1

DC SPECIFICATIONS

Symbol	Parameter	V _{CC}	Test Condition	T _A = 25°C 54HC and 74HC			-40 to 85°C 74HC		-55 to 125°C 54HC		Unit	
				Min.	Typ.	Max.	Min.	Max.	Min.	Max.		
V _{IH}	High Level Input Voltage	2.0 4.5 6.0		1.5 3.15 4.2	— — —	— — —	1.5 3.15 4.2	— — —	1.5 3.15 4.2	— — —	V	
V _{IL}	Low Level Input Voltage	2.0 4.5 6.0		— — —	— — —	0.5 1.35 1.8	— — —	0.5 1.35 1.8	— — —	0.5 1.35 1.8	V	
V _{OH}	High Level Output Voltage	2.0	V _{IN}	I _{OH}	1.9	2.0	—	1.9	—	1.9	—	V
		4.5	V _{IH} or V _{IL}	-20 μA	4.4	4.5	—	4.4	—	4.4	—	
		6.0		-4.0 mA	5.9	6.0	—	5.9	—	5.9	—	
		4.5		-5.2 mA	4.18	4.31	—	4.13	—	4.10	—	
		6.0			5.68	5.8	—	5.63	—	5.60	—	
V _{OL}	Low Level Output Voltage	2.0	V _{IH} or V _{IL}	20 μA	—	0	0.1	—	0.1	—	0.1	V
		4.5		—	0	0.1	—	0.1	—	0.1		
		6.0		—	0	0.1	—	0.1	—	0.1		
		4.5		4.0 mA	—	0.17	0.26	—	0.33	—	0.40	
		6.0		5.2 mA	—	0.18	0.26	—	0.33	—	0.40	
I _{IN}	Input Leakage Current	6.0	V _{IN} = V _{CC} or GND	—	—	±0.1	—	±1	—	±1	μA	
I _{CC}	Quiescent Supply Current	6.0	V _{IN} = V _{CC} or GND	—	—	4.0	—	40.0	—	80.0		

AC ELECTRICAL CHARACTERISTICS (V_{CC} = 5V, T_A = 25°C, C_L = 15pF, Input t_r = t_f = 6ns)

Symbol	Parameter	54HC and 74HC			Unit
		MIN.	TYP.	MAX.	
t _{TLH} t _{THL}	Output Transition Time		4	8	ns
t _{PLH} t _{PHL}	Propagation Delay Time CLOCK - Y _n		23	36	ns
t _{PLH} t _{PHL}	Propagation Delay Time G1, G2 - Y _n		15	24	ns

S G S-THOMSON

AC ELECTRICAL CHARACTERISTICS ($C_L = 50\text{pF}$, Input $t_r = t_f = 6\text{ns}$)

Symbol	Parameter	V_{CC}	Test Condition	$T_A = 25^\circ\text{C}$ 54HC and 74HC			-40 to 85°C 74HC		-55 to 125°C 54HC		Unit
				Min.	Typ.	Max.	Min.	Max.	Min.	Max.	
t_{TLH} t_{THL}	Output Transition Time	2.0 4.5 6.0		— — —	30 8 7	75 15 13	— — —	95 19 16	— — —	110 22 19	ns
t_{PLH} t_{PHL}	Propagation Delay Time (CLOCK - \bar{Y}_n)	2.0 4.5 6.0		— — —	112 27 23	210 42 36	— — —	265 53 45	— — —	315 63 54	ns
t_{PLH} t_{PHL}	Propagation Delay Time ($G1, G2$ - \bar{Y}_n)	2.0 4.5 6.0		— — —	72 18 16	140 28 24	— — —	175 35 30	— — —	210 42 36	ns
$t_{W(H)}$ $t_{W(L)}$	Minimum Pulse Width (CLOCK)	2.0 4.5 6.0		— — —	30 8 7	75 15 13	— — —	95 19 16	— — —	110 22 19	ns
t_s	Minimum Set-up Time (A, B, C)	2.0 4.5 6.0		— — —	12 3 2	50 10 9	— — —	65 13 11	— — —	75 15 13	ns
t_h	Minimum Hold Time (A, B, C)	2.0 4.5 6.0		— — —	— — —	5 5 5	— — —	5 5 5	— — —	5 5 5	ns
C_{IN}	Input Capacitance			—	5	10	—	10	—	10	pF
$C_{PD} (*)$	Power Dissipation Capacitance			—	89	—	—	—	—	—	

Note (*) C_{PD} is defined as the value of the IC's internal equivalent capacitance which is calculated from the operating current consumption without load (refer to Test circuit).

Average operating current can be obtained by the following: $I_{CC(opr.)} = C_{PD} \cdot V_{CC} \cdot f_{IN} + I_{CC}$

SWITCHING CHARACTERISTICS TEST CIRCUIT

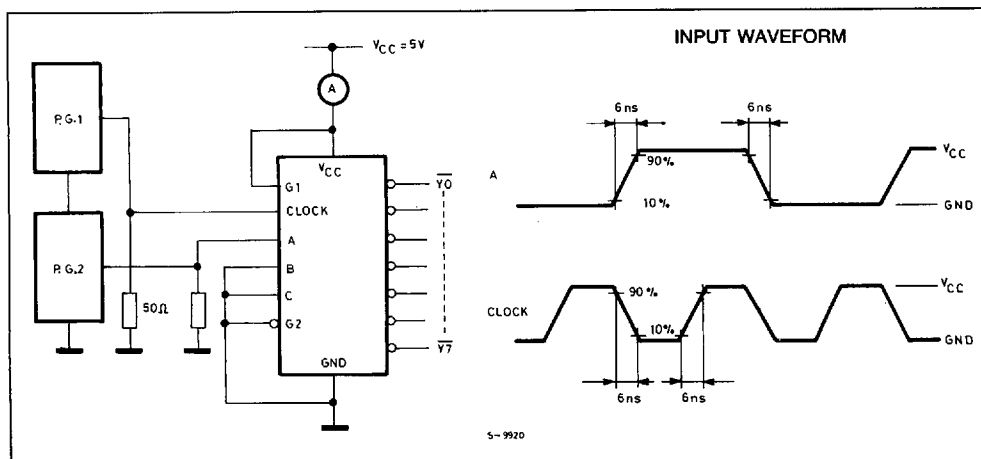

S-9920

SWITCHING CHARACTERISTICS TEST WAVEFORM

S G S-THOMSON

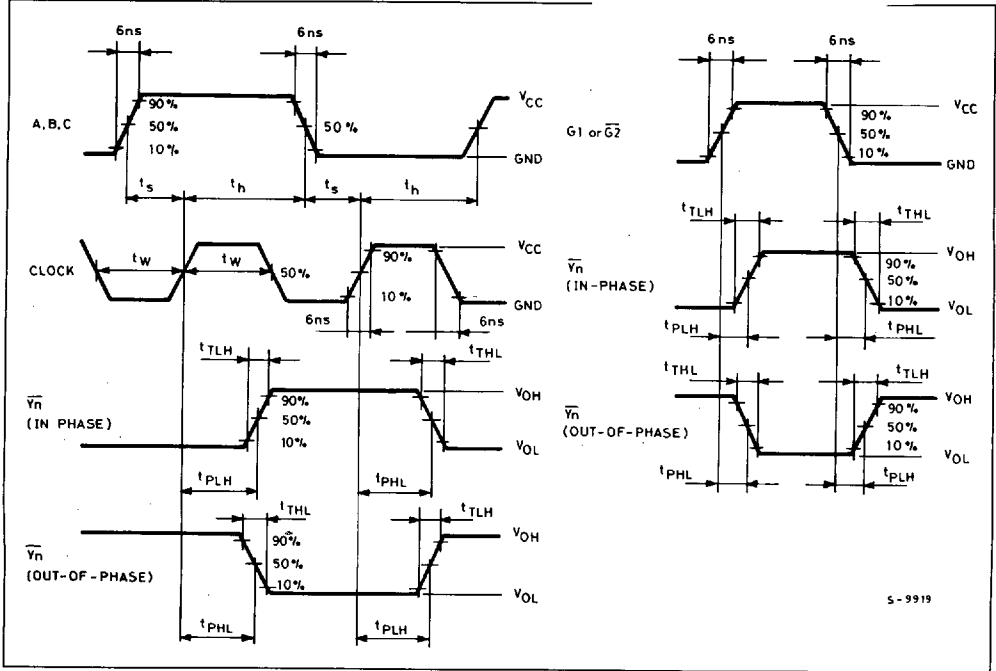

S-9919