

Customer Information Sheet

DRAWING No.: M80-4D1XXXXSI, M80-4D1XXXXSI-00-000-00-000

SHT 2 OF 2

IF IN DOUBT - ASK

©

NOT TO SCALE

THIRD ANGLE PROJECTION

ALL DIMENSIONS IN mm

SPECIFICATIONS:

MATERIAL:

MOULDING = GLASS-FILLED PPS, UL94V-0, BLACK
 CONTACT CLIP = BERYLLIUM COPPER
 CONTACT SHELL = BRASS
 BACKSHELL = ALUMINIUM ALLOY
 BANDIT TIE & J/SCREW = STAINLESS STEEL

FINISH:

CONTACTS
 05 = 0.3µ GOLD CLIP, 0.25-0.3µ GOLD SHELL
 42 = 0.3µ GOLD CLIP, 3.5-5.0µ 100% TIN SHELL OVER NICKEL
 BACKSHELL = NICKEL

ELECTRICAL:

RF ATTENUATION = 10kHz TO 400MHz @ >30dBs
 IN GENERAL ACCORDANCE WITH MIL STD 1377 (1971)
 CURRENT RATING AT 25°C = 3.0A MAX
 CURRENT RATING AT 85°C = 2.2A MAX
 WORKING VOLTAGE = 120V AC/DC
 VOLTAGE PROOF = 360V AC/DC
 CONTACT RESISTANCE = 25 mΩ MAX
 INSULATION RESISTANCE = 100 MΩ MIN

MECHANICAL:

INSERTION FORCE (∅0.5mm GAUGE) = 2.8N MAX
 WITHDRAWAL FORCE (∅0.5mm GAUGE) = 0.2N MIN

ENVIRONMENTAL:

TEMPERATURE RANGE = -55°C TO +121°C

PACKING:

SEE NOTES

FOR COMPLETE SPECIFICATION, SEE COMPONENT SPECIFICATION C005XX (LATEST ISSUE) AND C042XX (LATEST ISSUE)

NOTES:

- CONNECTOR IS SUPPLIED AS A KIT OF PARTS IN A BAG. BAGS WILL BE BULK PACKED INTO BOXES.
- FOR EXTRA CONTACTS, USE PART No.'s.
 M80-0110001 FOR M80-4D1XX42SI-00-000-00-000
 M80-0110005 FOR M80-4D1XX05SI-00-000-00-000
- FOR M80-4D1XXXXSI-00-000-00-000 THE RECOMMENDED WIRE TYPE = BS 3G 210 TYPE A, PTFE INSULATED 22 AWG. MAX INSULATION DIAMETER = ∅1.10mm, STRIP WIRE BY 2.00mm.
- RECOMMENDED HAND CRIMP TOOL FOR ALL CONTACTS = M22520/2-01 WITH POSITIONER T5747.
- CONTACT INSERTION & EXTRACTION TOOL = Z80-280.
- TO APPLY CIRCLIPS USE HARWIN TOOL = Z80-300.
- SEE TOOLING INSTRUCTION SHEET IS-32 FOR ASSEMBLY DETAILS AVAILABLE AT:
<http://www.harwin.com/downloads/instructions/>
- ALL PART LABELLING TO BE AS ORDER CODE, EITHER WITH TRAILING ZEROS OR LEFT BLANK AS PER ORDER CODE EXAMPLES 1 AND 2.
- 1 BANDIT TIE SUPPLIED PER KIT

ORDER CODE: **M80-4D1XXXXSI-XX-XXX-XX-XXX**

TOTAL No. OF CONTACTS _____
 06, 10, 14, 20, 26

FINISH CODE _____
 05 - GOLD CLIP, GOLD SHELL
 42 - GOLD CLIP, 100% TIN OVER NICKEL SHELL

NUMBER OF SPECIAL CONTACTS _____
 X's CAN BE DISPLAYED AS TRAILING ZEROS OR LEFT BLANK
 SEE EXAMPLE ORDER CODES FOR EXPLANATION.

EXAMPLE ORDER CODE 1: CONNECTOR WITH 20 LARGE BORE SIGNAL CONTACTS, GOLD CLIP AND GOLD SHELL

M80-4D12005SI-00-000-00-000

EXAMPLE ORDER CODE 2: CONNECTOR WITH 20 LARGE BORE SIGNAL CONTACTS, GOLD CLIP AND 100% TIN SHELL

M80-4D12042SI

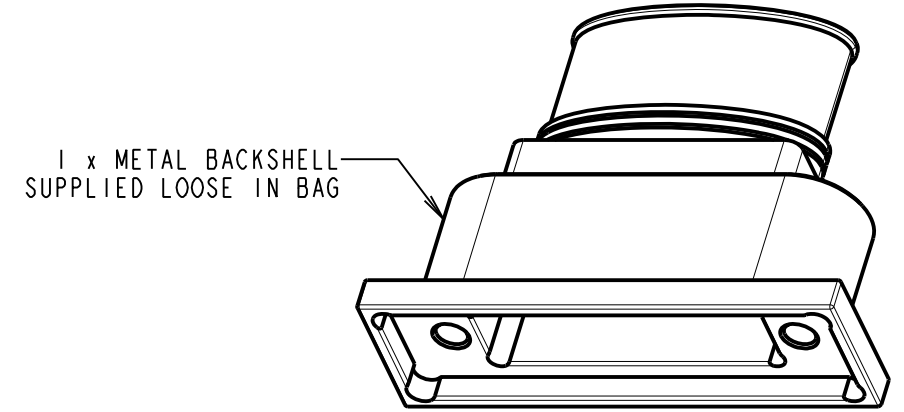
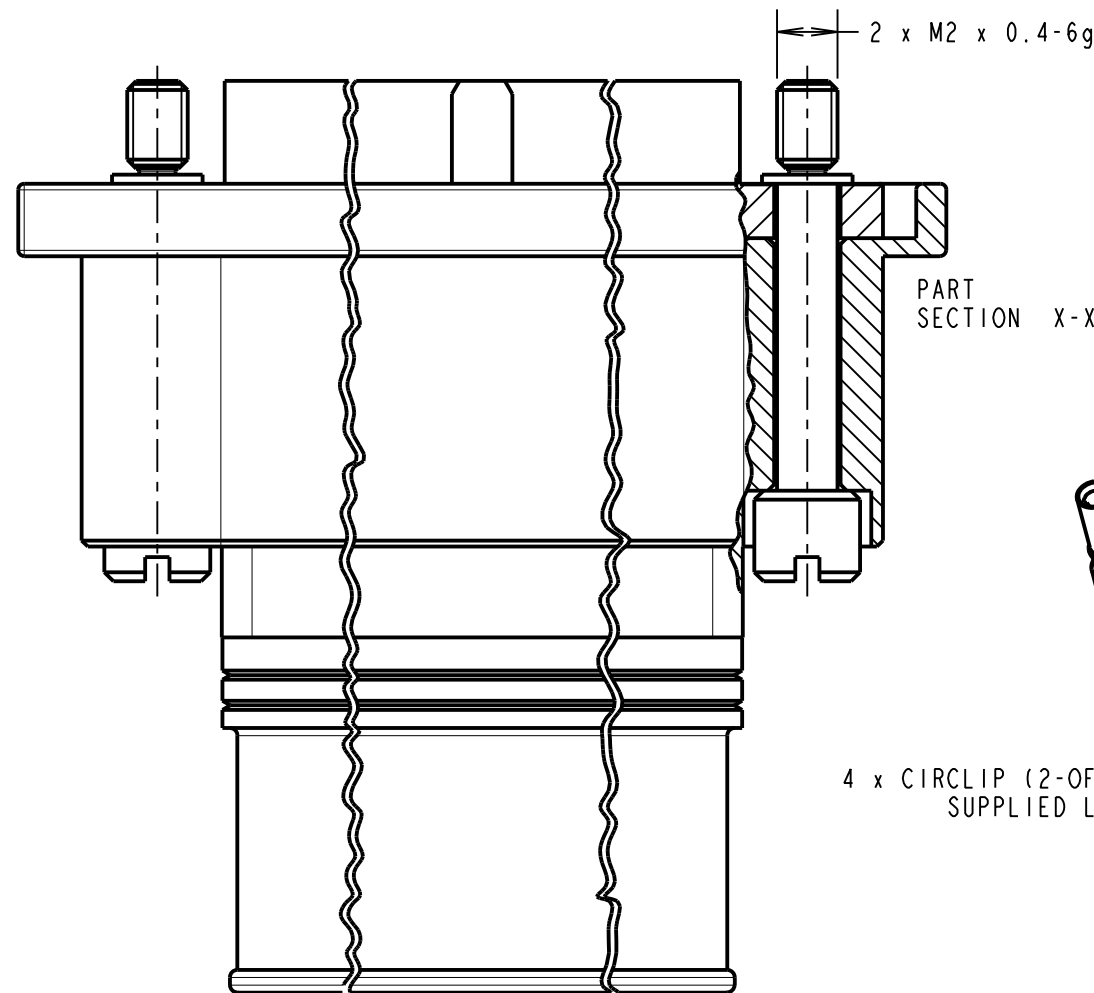
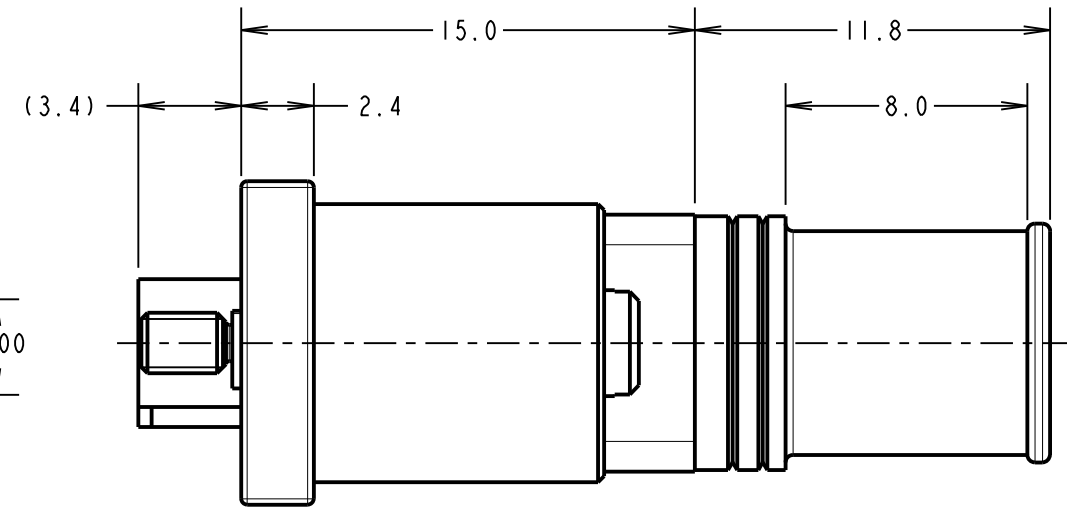
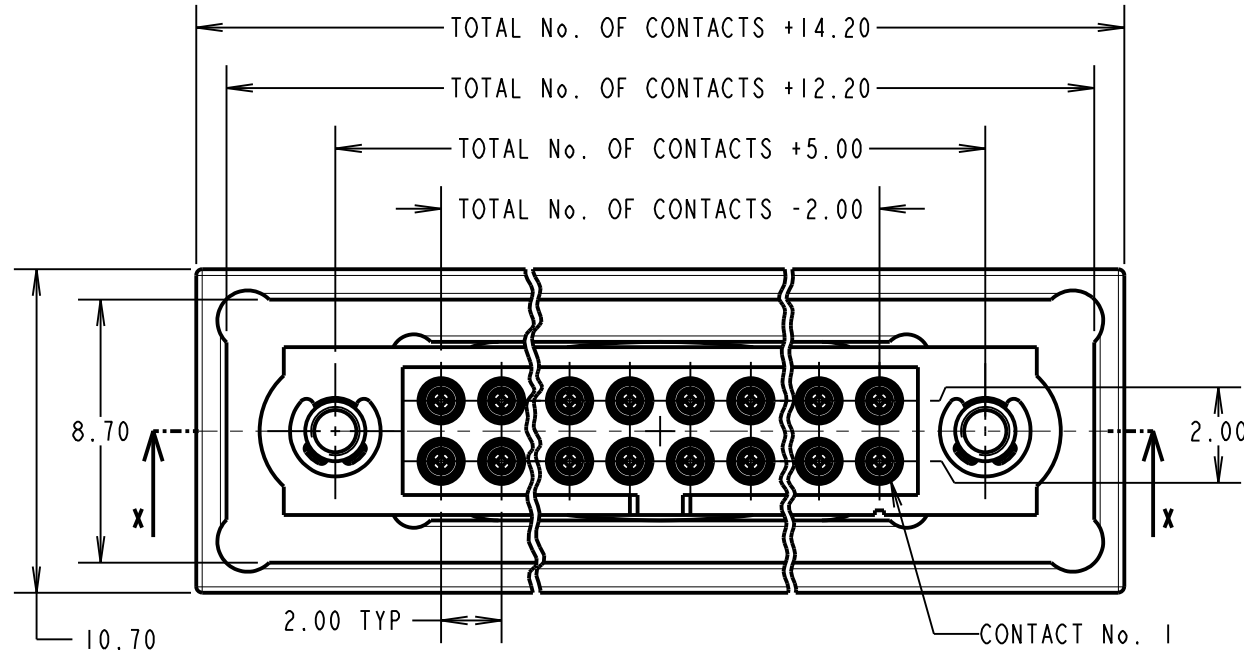

CONTACTS = M80-01100XX (QTY = TOTAL No. OF CONTACTS)
 05 = FINISH CODE '05'
 01 = FINISH CODE '42'

4 x CIRCLIP (2-OFF REQUIRED)
 SUPPLIED LOOSE IN BAG
 SEE NOTE 6

2 x M2 SLOTTED JACKSCREWS
 SUPPLIED LOOSE IN BAG

SF	3	31.01.11	11110
NAME	ISS.	DATE	C/NOTE
APPROVED:		S.FLOWER	
CHECKED:		R.ADE	
DRAWN:		S.FLOWER	
CUSTOMER REF.:			
ASSEMBLY DRG:			

HARWIN

HARWIN USA
 TEL: 603 893 5376
 FAX: 603 893 5396
 mis@harwin.com

HARWIN Europe (UK)
 TEL: 023 9231 4545
 FAX: 023 9231 4590
 mis@harwin.co.uk

HARWIN Asia
 TEL: +65 6 779 4909
 FAX: +65 6 779 3868
 mis@harwin.com.sg

THIS DRAWING AND ANY INFORMATION OR DESCRIPTIVE MATTER SET OUT HEREON ARE CONFIDENTIAL AND COPYRIGHT PROPERTY OF THE HARWIN GROUP AND MUST NOT BE DISCLOSED, LOANED, COPIED OR USED FOR MANUFACTURING, TENDERING OR FOR ANY OTHER PURPOSE WITHOUT THEIR WRITTEN PERMISSION.

TOLERANCES
 X. = ±1mm
 X.X = ±0.25mm
 X.XX = ±0.10mm
 X.XXX = ±0.01mm
 ANGLES = ±5°
 UNLESS STATED

MATERIAL:
 SEE ABOVE
FINISH: SEE ABOVE
S/AREA: mm²

TITLE: DATAMATE J-TEK FEMALE CRIMP (LARGE BORE) ASSY WITH METAL BACKSHELL
DRAWING NUMBER: M80-4D1XXXXSI, M80-4D1XXXXSI-00-000-00-000
 SHT 2 OF 2