

3-Terminal Fixed Voltage Positive Regulators

These voltage regulators are monolithic integrated circuits designed as fixed-voltage regulators for a wide variety of applications including local, on-card regulation. These regulators employ internal current limiting, thermal shutdown, and safe-area compensation.

With adequate heatsinking they can deliver output currents up to 1 ampere.

Although designed primarily as a fixed voltage regulator, these devices can be used with external components to obtain adjustable voltages and currents.

FEATURES

- Output Current up to 1 Ampere
- No External Components Required
- Internal Thermal Overload Protection
- Internal Short-Circuit Current Limiting
- Output Transistor Safe-Area Compensation
- Output Voltage Offered in 4% Tolerance

PIN ARRANGEMENT

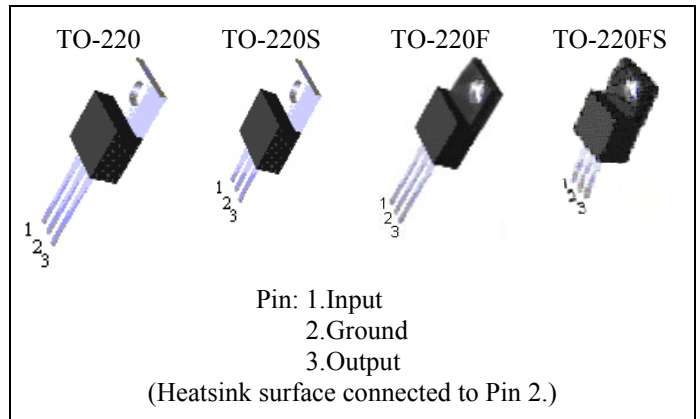

CIRCUIT SCHEMATIC

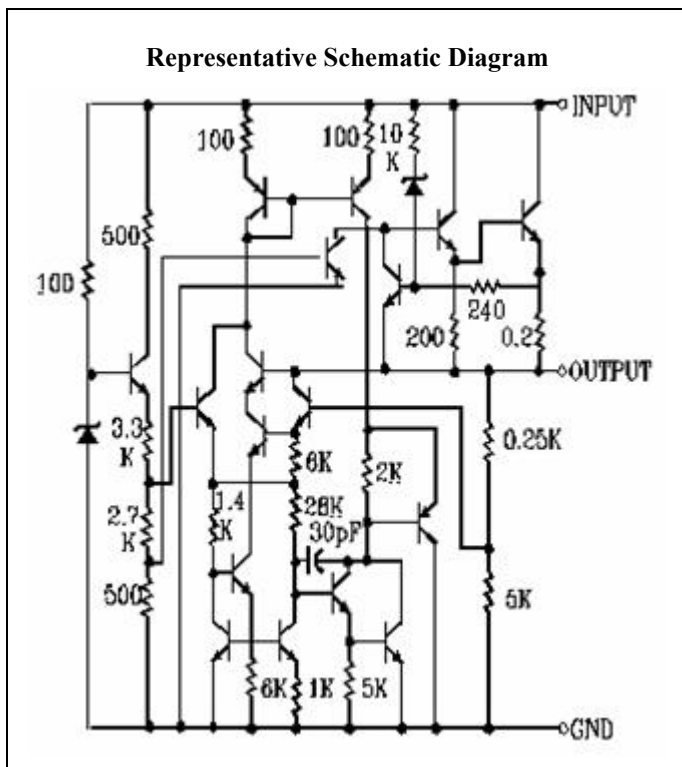

ORDERING INFORMATION

Device	Operating Temperature	Package
PJ78xxBCZ	-20°C ~ +85°C	TO-220
PJ78xxBCI		TO-220F

Standard Application

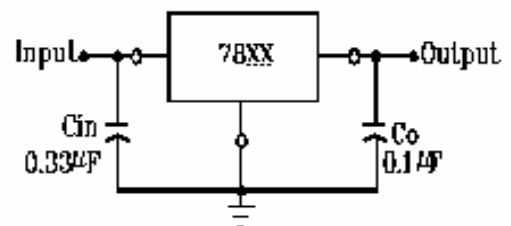

A common ground is required between the input and the output voltages. The input voltage must remain typically 2.0V above the output voltage even during the low point on the Input ripple voltage.

XX = these two digits of the type number indicate voltage.

* = Cin is required if regulator is located an appreciable distance from power supply filter.

** = Co is not needed for stability; however, it does improve transient response.

3-Terminal Fixed Voltage Positive Regulators

• **ABSOLUTE MAXIMUM RATINGS** (Ta=25°C)

RATING	SYMBOL	PJ7800B Series	UNIT
Input Voltage	Vin *	35	V
Input Voltage	Vin **	40	V
Power Dissipation	PD	Internally Limited	W
Operating Ambient Temperature	Topr	-20 to +85	°C
Operating Junction Temperature	Tj	0 to +150	°C
Storage Temperature	Tstg	-25 to +150	°C

Note: * PJ7805B to PJ7818B
 ** PJ7824B
 *** Follow the derating curve

• **PJ7805B ELECTRICAL CHARACTERISTICS**

(Vin=10V, Iout=500mA, 0°C≤Tj≤125°C, Cin=0.33 μF, Cout=0.1 μF; unless otherwise specified.)

CHARACTERISTICS	SYMBOL	TEST CONDITIONS	MIN.	TYP.	MAX.	UNIT	
Output Voltage	Vout	Tj=25°C	4.80	5	5.20	V	
		7V≤Vin≤20V, 5mA≤Iout≤1A, PD≤15W	4.75	5	5.25		
Line Regulation	REGline	Tj=25°C	7.5V≤Vin≤25V	--	3	100	mV
			8V≤Vin≤12V	--	1	50	mV
Load Regulation	REGload	Tj=25°C	5mA≤Iout≤1A	--	15	100	mV
			250mA≤Iout≤750mA	--	5	50	mV
Quiescent Current	Iq	Iout=0, Tj=25°C	--	4.2	8	mA	
Quiescent Current Change	ΔIq	7V≤Vin≤25V	--	--	1.3	mA	
		5mA≤Iout≤1A	--	--	0.5	mA	
Output Noise Voltage	Vn	10Hz≤f≤100KHz, Tj=25°C	--	40	--	μV	
Ripple Rejection Ratio	RR	f=120Hz, 8V≤Vin≤18V	62	78	--	dB	
Voltage Drop	Vdrop	Iout=1.0A, Tj=25°C	--	2	--	V	
Output Resistance	Rout	f=1KHz	--	17	--	mΩ	
Output Short Circuit Current	Ios	Tj=25°C	--	750	--	mA	
Peak Output Current	Io peak	Tj=25°C	--	2.2	--	A	
Temperature Coefficient of Output Voltage	ΔVout/ΔTj	Iout=5mA, 0°C≤Tj≤125°C	--	-0.6	--	mV/°C	

* Pulse testing techniques are used to maintain the junction temperature as close to the ambient temperature as possible, and thermal effects must be taken into account separately.

** This specification applies only for DC power dissipation permitted by absolute maximum ratings.

3-Terminal Fixed Voltage Positive Regulators

• **PJ7806B ELECTRICAL CHARACTERISTICS**

($V_{in}=11V$, $I_{out}=500mA$, $0^{\circ}C \leq T_j \leq 125^{\circ}C$, $C_{in}=0.33 \mu F$, $C_{out}=0.1 \mu F$; unless otherwise specified.)

CHARACTERISTICS	SYMBOL	TEST CONDITIONS	MIN.	TYP.	MAX.	UNIT	
Output Voltage	Vout	$T_j=25^{\circ}C$	5.75	6	6.25	V	
		$8V \leq V_{in} \leq 21V$, $5mA \leq I_{out} \leq 1A$, $PD \leq 15W$	6.3	6	6.3		
Line Regulation	REGline	$T_j=25^{\circ}C$	$8V \leq V_{in} \leq 25V$	--	5	120	mV
			$9V \leq V_{in} \leq 13V$	--	1.5	60	mV
Load Regulation	REGload	$T_j=25^{\circ}C$	$5mA \leq I_{out} \leq 1A$	--	14	120	mV
			$250mA \leq I_{out} \leq 750mA$	--	4	60	mV
Quiescent Current	Iq	$I_{out}=0$, $T_j=25^{\circ}C$	--	4.3	8	mA	
Quiescent Current Change	ΔIq	$8V \leq V_{in} \leq 25V$	--	--	1.3	mA	
		$5mA \leq I_{out} \leq 1A$	--	--	0.5	mA	
Output Noise Voltage	Vn	$10Hz \leq f \leq 100KHz$, $T_j=25^{\circ}C$	--	45	--	μV	
Ripple Rejection Ratio	RR	$f=120Hz$, $9V \leq V_{in} \leq 19V$	59	75	--	dB	
Voltage Drop	Vdrop	$I_{out}=1.0A$, $T_j=25^{\circ}C$	--	2	--	V	
Output Resistance	Rout	$f=1KHz$	--	19	--	m Ω	
Output Short Circuit Current	Ios	$T_j=25^{\circ}C$	--	550	--	mA	
Peak Output Current	Io peak	$T_j=25^{\circ}C$	--	2.2	--	A	
Temperature Coefficient of Output Voltage	$\Delta V_{out}/\Delta T_j$	$I_{out}=5mA$, $0^{\circ}C \leq T_j \leq 125^{\circ}C$	--	-0.7	--	mV/ $^{\circ}C$	

• **PJ7808B ELECTRICAL CHARACTERISTICS**

($V_{in}=14V$, $I_{out}=500mA$, $0^{\circ}C \leq T_j \leq 125^{\circ}C$, $C_{in}=0.33 \mu F$, $C_{out}=0.1 \mu F$; unless otherwise specified.)

CHARACTERISTICS	SYMBOL	TEST CONDITIONS	MIN.	TYP.	MAX.	UNIT	
Output Voltage	Vout	$T_j=25^{\circ}C$	7.69	8	8.32	V	
		$10.5V \leq V_{in} \leq 23V$, $5mA \leq I_{out} \leq 1A$, $PD \leq 15W$	7.61	8	8.40		
Line Regulation	REGline	$T_j=25^{\circ}C$	$10.5V \leq V_{in} \leq 25V$	--	6	160	mV
			$11V \leq V_{in} \leq 17V$	--	2	80	mV
Load Regulation	REGload	$T_j=25^{\circ}C$	$10mA \leq I_{out} \leq 1A$	--	12	160	mV
			$250mA \leq I_{out} \leq 750mA$	--	4	80	mV
Quiescent Current	Iq	$I_{out}=0$, $T_j=25^{\circ}C$	--	4.3	8	mA	
Quiescent Current Change	ΔIq	$10.5V \leq V_{in} \leq 25V$	--	--	1	mA	
		$5mA \leq I_{out} \leq 1A$	--	--	0.5	mA	
Output Noise Voltage	Vn	$10Hz \leq f \leq 100KHz$, $T_j=25^{\circ}C$	--	52	--	μV	
Ripple Rejection Ratio	RR	$f=120Hz$, $11V \leq V_{in} \leq 21V$	56	72	--	dB	
Voltage Drop	Vdrop	$I_{out}=1.0A$, $T_j=25^{\circ}C$	--	2	--	V	
Output Resistance	Rout	$f=1KHz$	--	16	--	m Ω	
Output Short Circuit Current	Ios	$T_j=25^{\circ}C$	--	450	--	mA	
Peak Output Current	Io peak	$T_j=25^{\circ}C$	--	2.2	--	A	
Temperature Coefficient of Output Voltage	$\Delta V_{out}/\Delta T_j$	$I_{out}=5mA$, $0^{\circ}C \leq T_j \leq 125^{\circ}C$	--	-0.8	--	mV/ $^{\circ}C$	

* Pulse testing techniques are used to maintain the junction temperature as close to the ambient temperature as possible, and thermal effects must be taken into account separately.

** This specification applies only for DC power dissipation permitted by absolute maximum ratings.

3-Terminal Fixed Voltage Positive Regulators

• **PJ7809B ELECTRICAL CHARACTERISTICS**

($V_{in}=15V$, $I_{out}=500mA$, $0^{\circ}C \leq T_j \leq 125^{\circ}C$, $C_{in}=0.33 \mu F$, $C_{out}=0.1 \mu F$; unless otherwise specified.)

CHARACTERISTICS	SYMBOL	TEST CONDITIONS	MIN.	TYP.	MAX.	UNIT	
Output Voltage	Vout	$T_j=25^{\circ}C$	8.65	9	9.36	V	
		$10.5V \leq V_{in} \leq 23V$, $5mA \leq I_{out} \leq 1A$, $PD \leq 15W$	8.57	9	9.45		
Line Regulation	REGline	$T_j=25^{\circ}C$	$11.5V \leq V_{in} \leq 26V$	--	6	180	mV
			$11.5V \leq V_{in} \leq 17V$	--	2	90	mV
Load Regulation	REGload	$T_j=25^{\circ}C$	$5mA \leq I_{out} \leq 1A$	--	12	180	mV
			$250mA \leq I_{out} \leq 750mA$	--	4	90	mV
Quiescent Current	Iq	$I_{out}=0$, $T_j=25^{\circ}C$	--	4.3	8	mA	
Quiescent Current Change	ΔIq	$11.5V \leq V_{in} \leq 26V$	--	--	1	mA	
		$5mA \leq I_{out} \leq 1A$	--	--	0.5	mA	
Output Noise Voltage	Vn	$10Hz \leq f \leq 100KHz$, $T_j=25^{\circ}C$	--	52	--	μV	
Ripple Rejection Ratio	RR	$f=120Hz$, $11.5V \leq V_{in} \leq 21.5V$	55	72	--	dB	
Voltage Drop	Vdrop	$I_{out}=1.0A$, $T_j=25^{\circ}C$	--	2	--	V	
Output Resistance	Rout	$f=1KHz$	--	16	--	$m\Omega$	
Output Short Circuit Current	Ios	$T_j=25^{\circ}C$	--	450	--	mA	
Peak Output Current	Io peak	$T_j=25^{\circ}C$	--	2.2	--	A	
Temperature Coefficient of Output Voltage	$\Delta V_{out}/\Delta T_j$	$I_{out}=5mA$, $0^{\circ}C \leq T_j \leq 125^{\circ}C$	--	-1	--	$mV/^{\circ}C$	

• **PJ7810B ELECTRICAL CHARACTERISTICS**

($V_{in}=16V$, $I_{out}=500mA$, $0^{\circ}C \leq T_j \leq 125^{\circ}C$, $C_{in}=0.33 \mu F$, $C_{out}=0.1 \mu F$; unless otherwise specified.)

CHARACTERISTICS	SYMBOL	TEST CONDITIONS	MIN.	TYP.	MAX.	UNIT	
Output Voltage	Vout	$T_j=25^{\circ}C$	9.6	10	10.4	V	
		$12.5V \leq V_{in} \leq 25V$, $5mA \leq I_{out} \leq 1A$, $PD \leq 15W$	9.5	10	10.5		
Line Regulation	REGline	$T_j=25^{\circ}C$	$12.5V \leq V_{in} \leq 28V$	--	7	200	mV
			$13V \leq V_{in} \leq 17V$	--	2	100	mV
Load Regulation	REGload	$T_j=25^{\circ}C$	$10mA \leq I_{out} \leq 1A$	--	12	200	mV
			$250mA \leq I_{out} \leq 750mA$	--	4	100	mV
Quiescent Current	Iq	$I_{out}=0$, $T_j=25^{\circ}C$	--	4.3	8	mA	
Quiescent Current Change	ΔIq	$12.5V \leq V_{in} \leq 28V$	--	--	1	mA	
		$5mA \leq I_{out} \leq 1A$	--	--	0.5	mA	
Output Noise Voltage	Vn	$10Hz \leq f \leq 100KHz$, $T_j=25^{\circ}C$	--	70	--	μV	
Ripple Rejection Ratio	RR	$f=120Hz$, $13V \leq V_{in} \leq 23V$	55	71	--	dB	
Voltage Drop	Vdrop	$I_{out}=1.0A$, $T_j=25^{\circ}C$	--	2	--	V	
Output Resistance	Rout	$f=1KHz$	--	18	--	$m\Omega$	
Output Short Circuit Current	Ios	$T_j=25^{\circ}C$	--	400	--	mA	
Peak Output Current	Io peak	$T_j=25^{\circ}C$	--	2.2	--	A	
Temperature Coefficient of Output Voltage	$\Delta V_{out}/\Delta T_j$	$I_{out}=5mA$, $0^{\circ}C \leq T_j \leq 125^{\circ}C$	--	-1	--	$mV/^{\circ}C$	

* Pulse testing techniques are used to maintain the junction temperature as close to the ambient temperature as possible, and thermal effects must be taken into account separately.

** This specification applies only for DC power dissipation permitted by absolute maximum ratings.

3-Terminal Fixed Voltage Positive Regulators

• PJ7812B ELECTRICAL CHARACTERISTICS

$V_{in}=19V$, $I_{out}=500mA$, $0^{\circ}C \leq T_j \leq 125^{\circ}C$, $C_{in}=0.33 \mu F$, $C_{out}=0.1 \mu F$; unless otherwise specified.)

CHARACTERISTICS	SYMBOL	TEST CONDITIONS	MIN.	TYP.	MAX.	UNIT	
Output Voltage	Vout	$T_j=25^{\circ}C$	11.53	12	12.48	V	
		$14.5V \leq V_{in} \leq 27V$, $5mA \leq I_{out} \leq 1A$, $PD \leq 15W$	11.42	12	12.60		
Line Regulation	REGline	$T_j=25^{\circ}C$	$14V \leq V_{in} \leq 30V$	--	10	240	mV
			$15V \leq V_{in} \leq 19V$	--	3	120	mV
Load Regulation	REGload	$T_j=25^{\circ}C$	$10mA \leq I_{out} \leq 1A$	--	12	240	mV
			$250mA \leq I_{out} \leq 750mA$	--	4	120	mV
Quiescent Current	Iq	$T_j=25^{\circ}C$, $I_{out}=0$	--	4.3	8	mA	
Quiescent Current Change	ΔIq	$14.5V \leq V_{in} \leq 30V$	--	--	1	mA	
		$5mA \leq I_{out} \leq 1A$	--	--	0.5	mA	
Output Noise Voltage	Vn	$10Hz \leq f \leq 100KHz$, $T_j=25^{\circ}C$	--	75	--	μV	
Ripple Rejection Ratio	RR	$f=120Hz$, $15V \leq V_{in} \leq 25V$	55	71	--	dB	
Voltage Drop	Vdrop	$I_{out}=1.0A$, $T_j=25^{\circ}C$	--	2	--	V	
Output Resistance	Rout	$f=1KHz$	--	18	--	m Ω	
Output Short Circuit Current	Ios	$T_j=25^{\circ}C$	--	350	--	mA	
Peak Output Current	Io peak	$T_j=25^{\circ}C$	--	2.2	--	A	
Temperature Coefficient of Output Voltage	$\Delta V_{out}/\Delta T_j$	$I_{out}=5mA$, $0^{\circ}C \leq T_j \leq 125^{\circ}C$	--	-1	--	mV/ $^{\circ}C$	

• PJ7815B ELECTRICAL CHARACTERISTICS

$(V_{in}=23V$, $I_{out}=500mA$, $0^{\circ}C \leq T_j \leq 125^{\circ}C$, $C_{in}=0.33 \mu F$, $C_{out}=0.1 \mu F$; unless otherwise specified.)

CHARACTERISTICS	SYMBOL	TEST CONDITIONS	MIN.	TYP.	MAX.	UNIT	
Output Voltage	Vout	$T_j=25^{\circ}C$	14.42	15	15.60	V	
		$17.5V \leq V_{in} \leq 30V$, $5mA \leq I_{out} \leq 1A$, $PD \leq 15W$	14.28	15	15.75		
Line Regulation	REGline	$T_j=25^{\circ}C$	$17.5V \leq V_{in} \leq 30V$	--	12	300	mV
			$18V \leq V_{in} \leq 22V$	--	3	150	mV
Load Regulation	REGload	$T_j=25^{\circ}C$	$10mA \leq I_{out} \leq 1A$	--	12	300	mV
			$250mA \leq I_{out} \leq 750mA$	--	4	150	mV
Quiescent Current	Iq	$T_j=25^{\circ}C$, $I_{out}=0$	--	4.3	8	mA	
Quiescent Current Change	ΔIq	$17.5V \leq V_{in} \leq 30V$	--	--	1	mA	
		$5mA \leq I_{out} \leq 1A$	--	--	0.5	mA	
Output Noise Voltage	Vn	$10Hz \leq f \leq 100KHz$, $T_j=25^{\circ}C$	--	90	--	μV	
Ripple Rejection Ratio	RR	$f=120Hz$, $18V \leq V_{in} \leq 28V$	54	70	--	dB	
Voltage Drop	Vdrop	$I_{out}=1.0A$, $T_j=25^{\circ}C$	--	2	--	V	
Output Resistance	Rout	$f=1KHz$	--	19	--	m Ω	
Output Short Circuit Current	Ios	$T_j=25^{\circ}C$	--	230	--	mA	
Peak Output Current	Io peak	$T_j=25^{\circ}C$	--	2.2	--	A	
Temperature Coefficient of Output Voltage	$\Delta V_{out}/\Delta T_j$	$I_{out}=5mA$, $0^{\circ}C \leq T_j \leq 125^{\circ}C$	--	-1	--	mV/ $^{\circ}C$	

* Pulse testing techniques are used to maintain the junction temperature as close to the ambient temperature as possible, and thermal effects must be taken into account separately.

** This specification applies only for DC power dissipation permitted by absolute maximum ratings.

3-Terminal Fixed Voltage Positive Regulators

• PJ7818B ELECTRICAL CHARACTERISTICS

(Vin=27V, Iout=500mA, 0°C≤Tj≤125°C, Cin=0.33 μF, Cout=0.1 μF; unless otherwise specified.)

CHARACTERISTICS	SYMBOL	TEST CONDITIONS	MIN.	TYP.	MAX.	UNIT	
Output Voltage	Vout	Tj=25°C	17.30	18	18.72	V	
		21V≤Vin≤33V, 5mA≤Iout≤1A, PD≤15W	17.14	18	18.90		
Line Regulation	REGline	Tj=25°C	21V≤Vin≤33V	--	15	360	mV
			22V≤Vin≤26V	--	5	180	mV
Load Regulation	REGload	Tj=25°C	10mA≤Iout≤1A	--	12	360	mV
			250mA≤Iout≤750mA	--	4	180	mV
Quiescent Current	Iq	Tj=25°C, Iout=0	--	4.5	8	mA	
Quiescent Current Change	ΔIq	21V≤Vin≤33V	--	--	1	mA	
		5mA≤Iout≤1A	--	--	0.5	mA	
Output Noise Voltage	Vn	10Hz≤f≤100KHz, Tj=25°C	--	110	--	μV	
Ripple Rejection Ratio	RR	f=120Hz, 21V≤Vin≤31V	54	70	--	dB	
Voltage Drop	Vdrop	Iout=1.0A, Tj=25°C	--	2	--	V	
Output Resistance	Rout	f=1KHz	--	22	--	mΩ	
Output Short Circuit Current	Ios	Tj=25°C	--	200	--	mA	
Peak Output Current	Io peak	Tj=25°C	--	2.2	--	A	
Temperature Coefficient of Output Voltage	ΔVout/ΔTj	Iout=5mA, 0°C≤Tj≤125°C	--	-1	--	mV/°C	

• PJ7824B BELECTRICAL CHARACTERISTICS

(Vin=33V, Iout=500mA, 0°C≤Tj≤125°C, Cin=0.33 μF, Cout=0.1 μF; unless otherwise specified.)

CHARACTERISTICS	SYMBOL	TEST CONDITIONS	MIN.	TYP.	MAX.	UNIT	
Output Voltage	Vout	Tj=25°C	23.07	24	24.96	V	
		26V≤Vin≤38V, 5mA≤Iout≤1A, PD≤15W	22.85	24	25.20		
Line Regulation	REGline	Tj=25°C	26V≤Vin≤38V	--	18	480	mV
			27V≤Vin≤32V	--	6	240	mV
Load Regulation	REGload	Tj=25°C	10mA≤Iout≤1A	--	12	480	mV
			250mA≤Iout≤750mA	--	4	240	mV
Quiescent Current	Iq	Iout=0, Tj=25°C	--	4.6	8	mA	
Quiescent Current Change	ΔIq	26V≤Vin≤38V	--	--	1	mA	
		5mA≤Iout≤1A	--	--	0.5	mA	
Output Noise Voltage	Vn	10Hz≤f≤100KHz, Tj=25°C	--	170	--	μV	
Ripple Rejection Ratio	RR	f=120Hz, 26V≤Vin≤36V	54	70	--	dB	
Voltage Drop	Vdrop	Iout=1.0A, Tj=25°C	--	2	--	V	
Output Resistance	Rout	f=1KHz	--	28	--	mΩ	
Output Short Circuit Current	Ios	Tj=25°C	--	150	--	mA	
Peak Output Current	Io peak	Tj=25°C	--	2.2	--	A	
Temperature Coefficient of Output Voltage	ΔVout/ΔTj	Iout=5mA, 0°C≤Tj≤125°C	--	-1.5	--	mV/°C	

* Pulse testing techniques are used to maintain the junction temperature as close to the ambient temperature as possible, and thermal effects must be taken into account separately.

** This specification applies only for DC power dissipation permitted by absolute maximum ratings.

3-Terminal Fixed Voltage Positive Regulators

FIGURE 1 - WORST CASE POWER DISSIPATION VERSUS AMBIENT TEMPERATURE

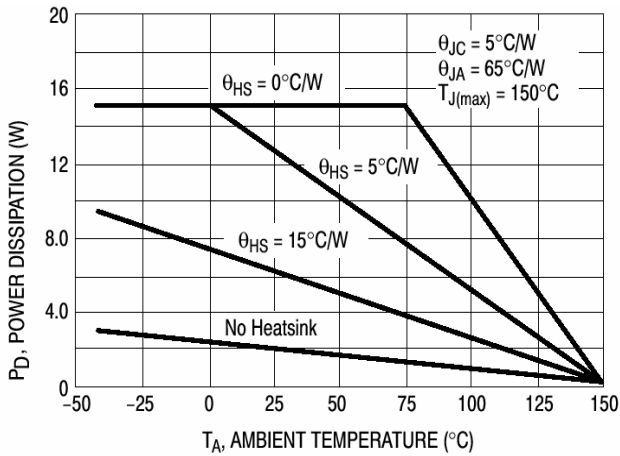

FIGURE 2 - PEAK OUTPUT CURRENT AS A FUNCTION OF INPUT-OUTPUT DIFFERENTIAL VOLTAGE

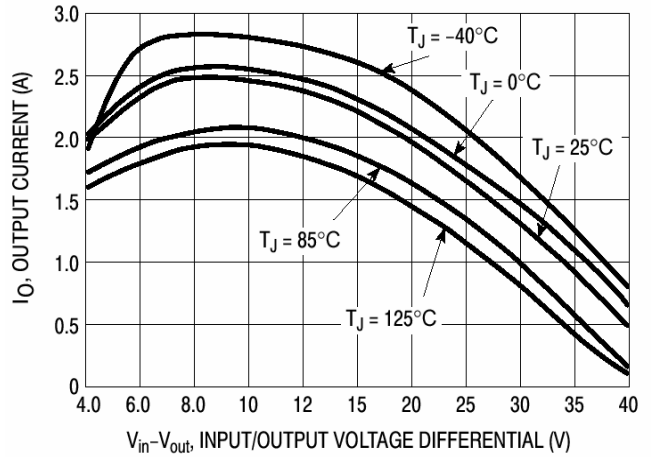

FIGURE 3 - QUIESCENT CURRENT AS A FUNCTION OF TEMPERATURE

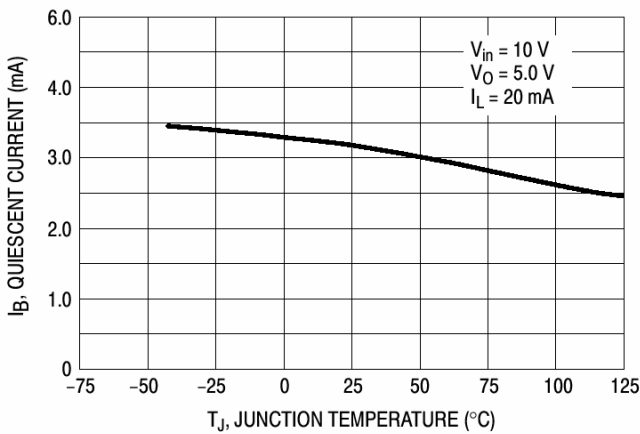

FIGURE 4 - INPUT OUTPUT DIFFERENTIAL AS A FUNCTION OF JUNCTION TEMPERATURE

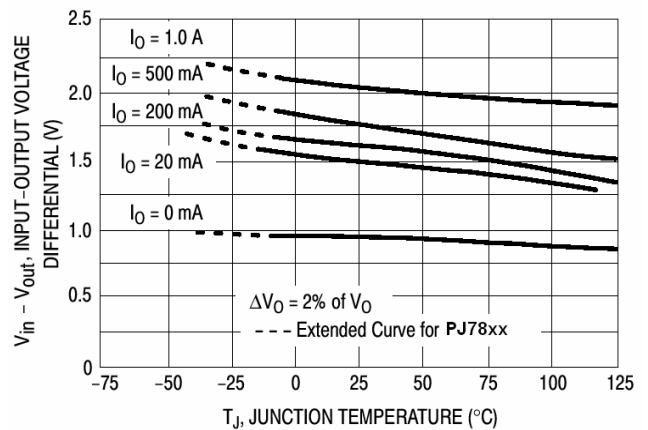

FIGURE 5 - OUTPUT VOLTAGE AS A FUNCTION OF JUNCTION TEMPERATURE

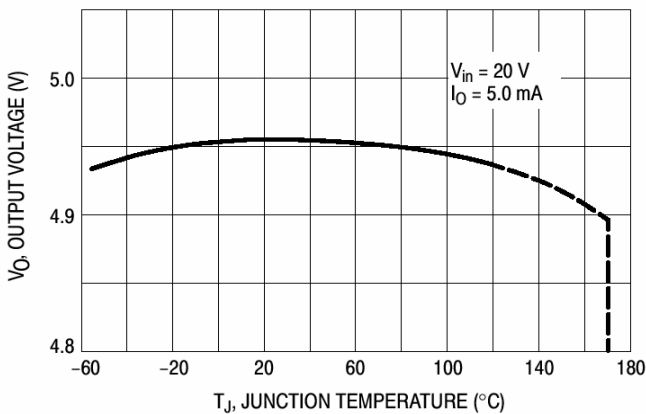
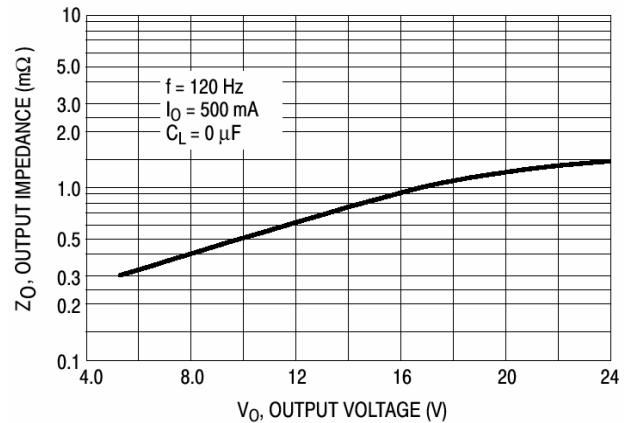

FIGURE 6 - OUTPUT IMPEDANCE AS A FUNCTION OF OUTPUT VOLTAGE



3-Terminal Fixed Voltage Positive Regulators

FIGURE 7 - RIPPLE REJECTION AS A FUNCTION OF OUTPUT VOLTAGE

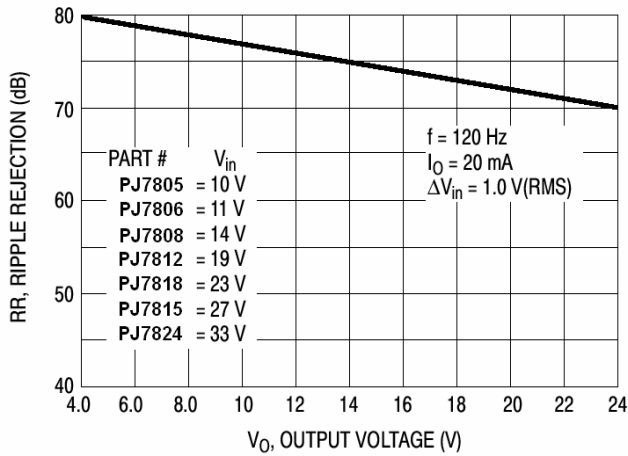
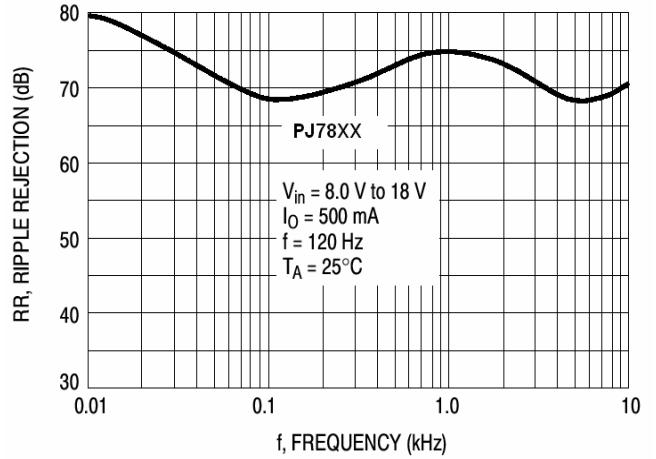
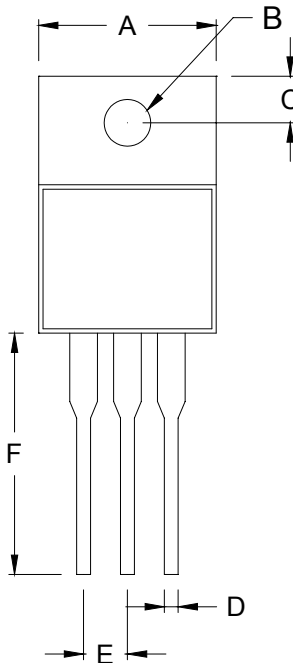

FIGURE 8 - RIPPLE REJECTION AS A FUNCTION OF FREQUENCY



TO-220 Mechanical drawing

1.Top View



2.Side View

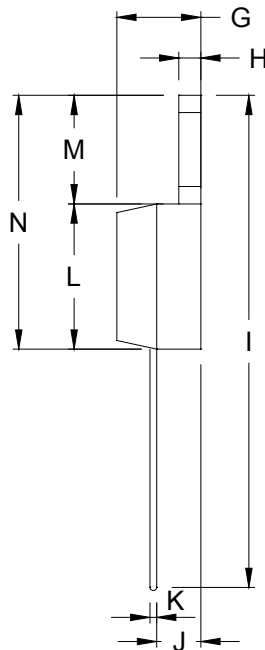

DIM	TO-220-3L DIMENSION			
	MILLIMETERS		INCHES	
	MIN	MAX	MIN	MAX
A	10.00	10.50	0.393	0.413
B	3.70	3.90	0.145	0.154
C	2.65	2.80	0.104	0.110
D	0.80	0.90	0.031	0.035
E	2.50	2.60	0.098	0.102
F	13.80	14.00	0.543	0.551
G	4.50	4.60	0.177	0.181
H	1.24	1.28	0.048	0.050
I	28.60	28.80	1.125	1.134
J	2.48	2.55	0.097	0.100
K	0.36	0.40	0.014	0.016
L	8.40	8.70	0.330	0.343
M	6.10	6.40	0.240	0.252
N	14.70	14.90	0.578	0.587

3-Terminal Fixed Voltage Positive Regulators

TO-220F Mechanical drawing

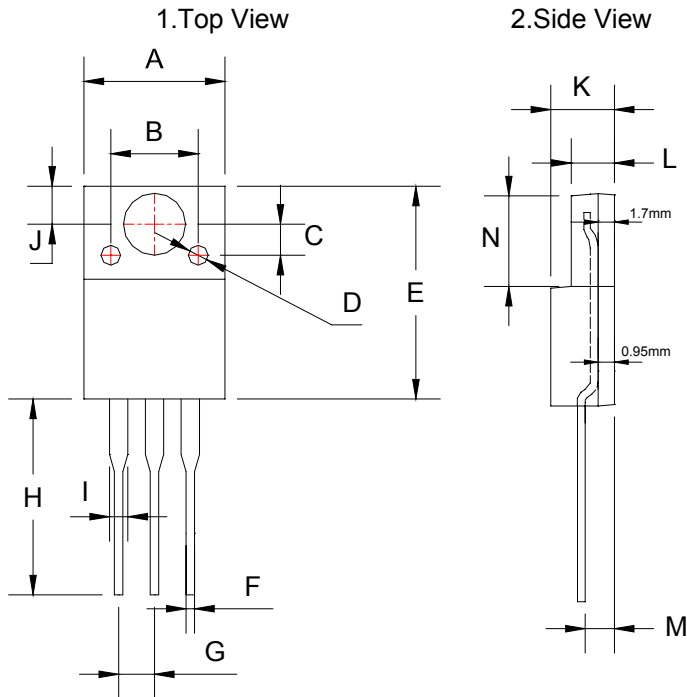

TO-220F DIMENSION				
DIM	MILLIMETERS		INCHES	
	MIN	MAX	MIN	MAX
A	10.05	10.20	0.395	0.402
B	6.10	6.30	0.240	0.248
C	2.10	2.35	0.082	0.093
D	? 1.30	? 1.40	? 0.051	? 0.055
E	15.00	15.20	0.590	0.598
F	0.50	0.60	0.020	0.024
G	2.40	2.60	0.094	0.102
H	13.40	13.65	0.527	0.537
I	1.15	1.35	0.045	0.053
J	2.60	2.80	0.102	0.110
K	4.40	4.60	0.173	0.181
L	3.02	3.07	0.118	0.121
M	2.60	2.80	0.102	0.110
N	6.55	6.65	0.258	0.262

TO-220FS Mechanical drawing

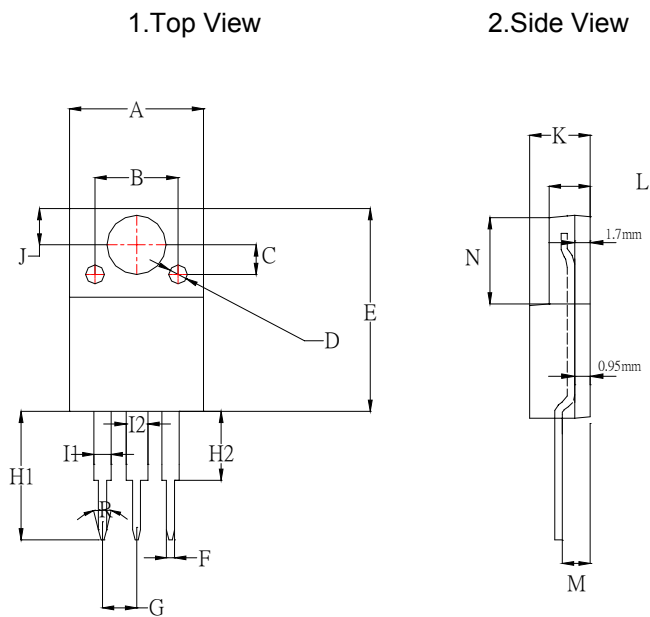

TO-220FS DIMENSION				
DIM	MILLIMETERS		INCHES	
	MIN	MAX	MIN	MAX
A	10.05	10.20	0.395	0.402
B	6.10	6.30	0.240	0.248
C	2.10	2.35	0.082	0.093
D	Φ1.3	Φ1.4	Φ0.051	Φ0.055
E	15.00	15.20	0.590	0.598
F	0.50	0.60	0.020	0.024
G	2.40	2.60	0.094	0.102
H1	6.50	6.90	0.256	0.272
H2	3.50	3.70	0.318	0.146
I1	1.15	1.35	0.045	0.053
I2	1.50	1.70	0.059	0.067
J	2.60	2.80	0.102	0.110
K	4.40	4.60	0.173	0.181
L	3.02	3.07	0.118	0.121
M	2.60	2.80	0.102	0.110
N	6.55	6.65	0.258	0.262
R	55°	65°	-	-

3-Terminal Fixed Voltage Positive Regulators

TO-220S Mechanical drawing

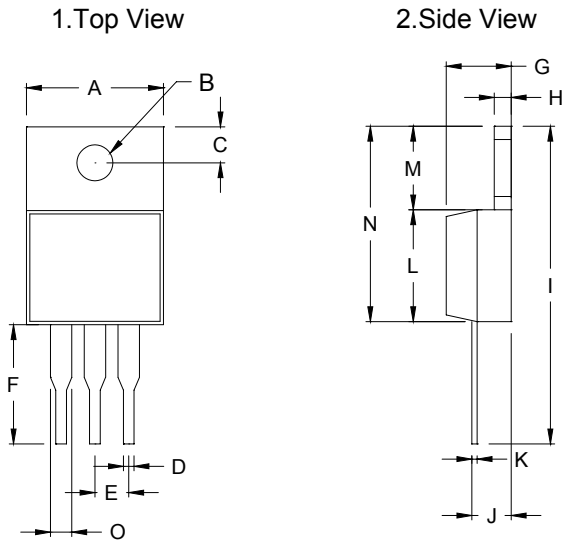

DIM	TO-220-3L DIMENSION			
	MILLIMETERS		INCHES	
	MIN	MAX	MIN	MAX
A	10.00	10.45	0.393	0.411
B	3.70	3.90	0.145	0.154
C	2.65	2.80	0.104	0.110
D	0.80	0.90	0.031	0.035
E	2.50	2.60	0.098	0.102
F	6.50	6.90	0.255	0.270
G	4.40	4.80	0.177	0.189
H	1.24	1.28	0.048	0.050
I	21.40	21.60	0.842	0.850
J	2.20	2.90	0.086	0.114
K	0.36	0.40	0.014	0.016
L	8.40	8.70	0.330	0.343
M	6.10	6.40	0.240	0.252
N	14.70	14.90	0.578	0.587
O	1.10	1.40	0.043	0.055