

Document No.	853-0101
ECN No.	95206
Date of issue	November 29, 1988
Status	Product Specification
FAST Products	

FEATURES

- 3-state outputs for bus interface and multiplex expansion
- Common select inputs
- Separate Output Enable inputs

DESCRIPTION

The 74F253 has two identical 4-input multiplexers with 3-state outputs which select two bits from four sources selected by common Select inputs (S_0, S_1). When the individual Output Enable ($\overline{OE}_a, \overline{OE}_b$) inputs of the 4-input multiplexers are High, the outputs are forced to a high impedance (Hi-Z) state.

The 'F253 is the logic implementation of a 2-pole, 4-position switch; the position of the switch being determined by the logic levels supplied to the two common Select inputs.

To avoid exceeding the maximum current ratings when the outputs of the 3-state devices are tied together, all but one device must be in the high-impedance state. Therefore, only one Output Enable must be active at a time.

PIN CONFIGURATION

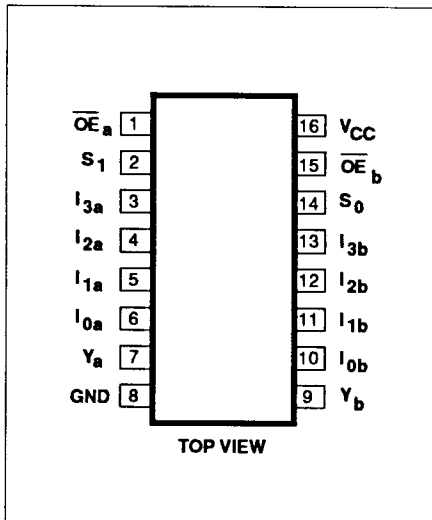

FAST 74F253

Multiplexer

Dual 4-Input Multiplexer (3-State)

TYPE	TYPICAL PROPAGATION DELAY	TYPICAL SUPPLY CURRENT (TOTAL)
74F253	7.0ns	12mA

ORDERING INFORMATION

PACKAGES	COMMERCIAL RANGE $V_{CC} = 5V \pm 10\%$; $T_A = 0^\circ C$ to $+70^\circ C$
16-Pin Plastic DIP	N74F253N
16-Pin Plastic SO	N74F253D

INPUT AND OUTPUT LOADING AND FAN-OUT TABLE

PINS	DESCRIPTION	74F(U.L.) HIGH/LOW	LOAD VALUE HIGH/LOW
$I_{0a} - I_{3a}$	Port A data inputs	1.0/1.0	20 μ A/0.6mA
$I_{0b} - I_{3b}$	Port B data inputs	1.0/1.0	20 μ A/0.6mA
S_0, S_1	Common Select inputs	1.0/1.0	20 μ A/0.6mA
\overline{OE}_a	Port A Output Enable input (active Low)	1.0/1.0	20 μ A/0.6mA
\overline{OE}_b	Port B Output Enable input (active Low)	1.0/1.0	20 μ A/0.6mA
Y_a, Y_b	3-state outputs	150/40	3mA/24mA

NOTE:

One (1.0) FAST Unit Load is defined as: 20 μ A in the High state and 0.6mA in the Low state.

LOGIC SYMBOL

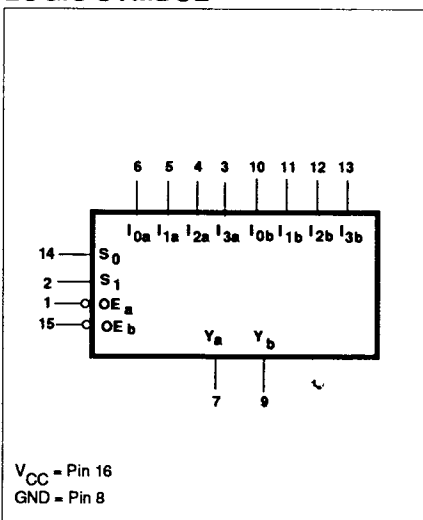

LOGIC SYMBOL (IEEE/IEC)

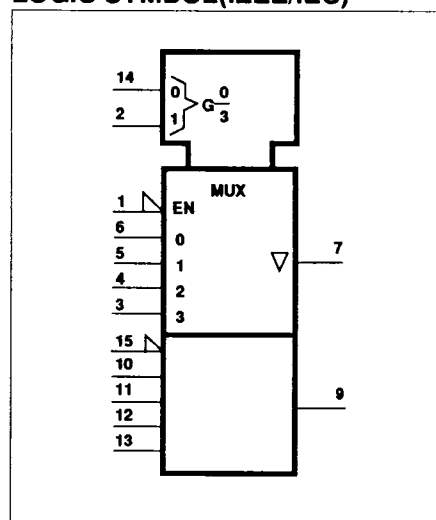

Multiplexer

FAST 74F253

LOGIC DIAGRAM

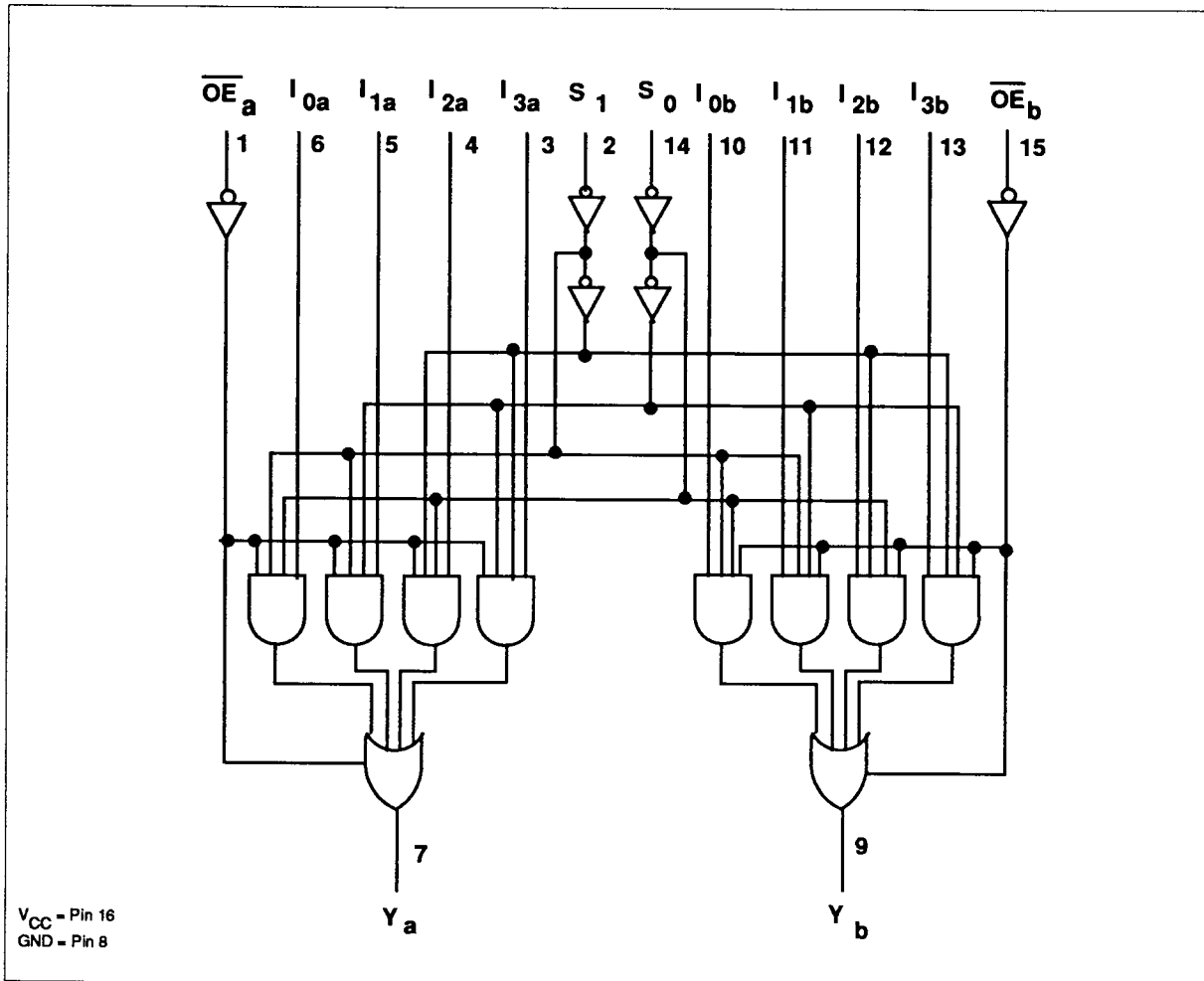

FUNCTION TABLE

INPUTS							OUTPUT
S ₀	S ₁	I ₀	I ₁	I ₂	I ₃	OE	Y
X	X	X	X	X	X	H	Z
L	L	L	X	X	X	L	L
L	L	H	X	X	X	L	H
H	L	X	L	X	X	L	L
H	L	X	H	X	X	L	H
L	H	X	X	L	X	L	L
L	H	X	X	H	X	L	H
H	H	X	X	X	L	L	L
H	H	X	X	X	H	L	H

H = High voltage level
L = Low voltage level
X = Don't care
Z = High impedance "off" state

Multiplexer

FAST 74F253

ABSOLUTE MAXIMUM RATINGS (Operation beyond the limits set forth in this table may impair the useful life of the device. Unless otherwise noted these limits are over the operating free-air temperature range.)

SYMBOL	PARAMETER	RATING	UNIT
V_{CC}	Supply voltage	-0.5 to +7.0	V
V_{IN}	Input voltage	-0.5 to +7.0	V
I_{IN}	Input current	-30 to +5	mA
V_{OUT}	Voltage applied to output in High output state	-0.5 to + V_{CC}	V
I_{OUT}	Current applied to output in Low output state	48	mA
T_A	Operating free-air temperature range	0 to +70	°C
T_{STG}	Storage temperature	-65 to +150	°C

RECOMMENDED OPERATING CONDITIONS

SYMBOL	PARAMETER	LIMITS			UNIT
		Min	Nom	Max	
V_{CC}	Supply voltage	4.5	5.0	5.5	V
V_{IH}	High-level input voltage	2.0			V
V_{IL}	Low-level input voltage			0.8	V
I_{IK}	Input clamp current			-18	mA
I_{OH}	High-level output current			-3	mA
I_{OL}	Low-level output current			24	mA
T_A	Operating free-air temperature range	0		70	°C

DC ELECTRICAL CHARACTERISTICS (Over recommended operating free-air temperature range unless otherwise noted.)

SYMBOL	PARAMETER	TEST CONDITIONS ¹	LIMITS			UNIT		
			Min	Typ ²	Max			
V_{OH}	High-level output voltage	$V_{CC} = \text{MIN}, V_{IL} = \text{MAX}$	$\pm 10\%V_{CC}$	2.4		V		
		$V_{IH} = \text{MIN}, I_{OH} = \text{MAX}$	$\pm 5\%V_{CC}$	2.7	3.3	V		
V_{OL}	Low-level output voltage	$V_{CC} = \text{MIN}, V_{IL} = \text{MAX}$	$\pm 10\%V_{CC}$		0.35	0.50	V	
		$V_{IH} = \text{MIN}, I_{OL} = \text{MAX}$	$\pm 5\%V_{CC}$		0.35	0.50	V	
V_{IK}	Input clamp voltage	$V_{CC} = \text{MIN}, I_I = I_{IK}$			-0.73	-1.2	V	
I_I	Input current at maximum input voltage	$V_{CC} = \text{MAX}, V_I = 7.0V$				100	μA	
I_{IH}	High-level input current	$V_{CC} = \text{MAX}, V_I = 2.7V$				20	μA	
I_{IL}	Low-level input current	$V_{CC} = \text{MAX}, V_I = 0.5V$				-0.6	mA	
I_{OZH}	Off-state output current, High-level voltage applied	$V_{CC} = \text{MAX}, V_O = 2.7V$				50	μA	
I_{OZL}	Off-state output current, Low-level voltage applied	$V_{CC} = \text{MAX}, V_O = 0.5V$				-50	μA	
I_{OS}	Short circuit output current ³	$V_{CC} = \text{MAX}$				-60	-150	mA
I_{CC}	Supply current (total)	$V_{CC} = \text{MAX}$		$\overline{OE}_n = \text{GND}, S_n = I_n = 4.5V$	10	16	mA	
				$\overline{OE}_n = S_n = I_n = \text{GND}$	12	23	mA	
				$\overline{OE}_n = 4.5V, S_n = I_n = \text{GND}$	14	23	mA	

NOTES:

- For conditions shown as MIN or MAX, use the appropriate value specified under recommended operating conditions for the applicable type.
- All typical values are at $V_{CC} = 5V, T_A = 25^\circ C$.
- Not more than one output should be shorted at a time. For testing I_{OS} , the use of high-speed test apparatus and/or sample-and-hold techniques are preferable in order to minimize internal heating and more accurately reflect operational values. Otherwise, prolonged shorting of a High output may raise the chip temperature well above normal and thereby cause invalid readings in other parameter tests. In any sequence of parameter tests, I_{OS} tests should be performed last.

Multiplexer

FAST 74F253

AC ELECTRICAL CHARACTERISTICS

SYMBOL	PARAMETER	TEST CONDITION	LIMITS						UNIT
			$T_A = +25^\circ\text{C}$ $V_{CC} = 5\text{V}$ $C_L = 50\text{pF}$ $R_L = 500\Omega$			$T_A = 0^\circ\text{C to } +70^\circ\text{C}$ $V_{CC} = 5\text{V} \pm 10\%$ $C_L = 50\text{pF}$ $R_L = 500\Omega$			
			Min	Typ	Max	Min	Max		
t_{PLH} t_{PHL}	Propagation delay I_n to Y_n	Waveform 1	3.0 3.0	4.5 5.0	7.0 7.0	3.0 3.0	7.5 8.0	ns	
t_{PLH} t_{PHL}	Propagation delay S_n to Y_n	Waveform 1	4.5 5.0	7.5 8.5	10.5 11.0	4.5 4.5	11.0 12.0	ns	
t_{PZH} t_{PZL}	Output Enable time to High or Low level	Waveform 2 Waveform 3	3.0 3.0	6.5 6.5	8.0 8.0	3.0 3.0	9.0 9.0	ns	
t_{PHZ} t_{PLZ}	Output Disable time from High or Low level	Waveform 2 Waveform 3	2.5 2.0	3.5 3.0	5.0 5.0	2.0 1.5	6.0 6.0	ns	

AC WAVEFORMS

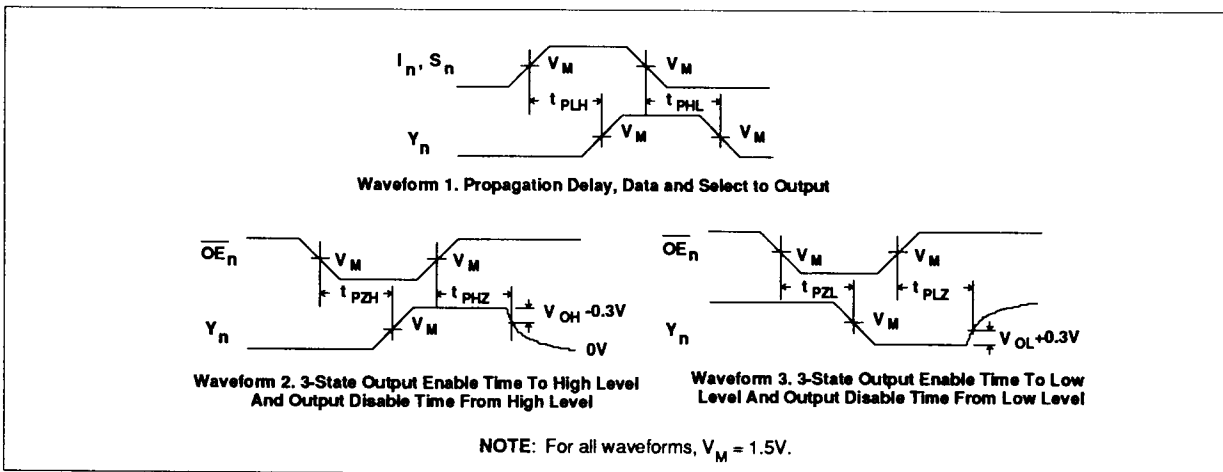

TEST CIRCUIT AND WAVEFORMS

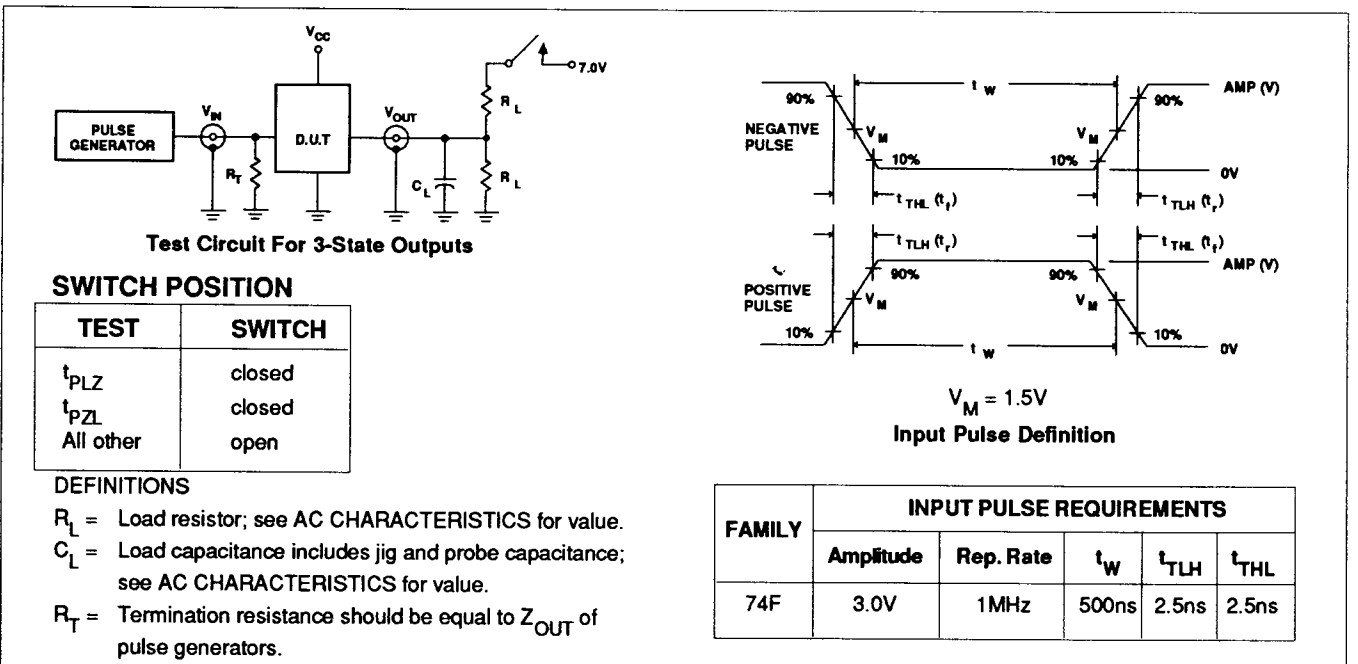

VI. COMMERCIAL PRODUCT SPECIAL PROCESSING T-90-20

SUPR II LEVEL B PRICING ADDERS

SUPR II LEVEL B

Signetics Upgraded Product Reliability (SUPR) program is designed to provide customers whose systems require an infant mortality level less than that of our non-burned-in products (which is typically below 1000 PPM).

DEVICE AVAILABILITY

Products available for Level B processing are identified in the Price Book with a "B" suffix to the basic part number.

PRODUCT FAMILY	SUGGESTED RESALE ADDERS		
	1-99	100-999	OVER 1000
LIN	.14	.14	.11
LOG (TTL)			
(SSI)	.12	.10	.08
(MSI)	.16	.14	.11
(OCT)	.16	.14	.11
(CTM)	.16	.14	.11
LOG (ECL)			
(SSI)	.25	.23	.20
(MSI)	.25	.23	.20
LOG (LSI)	Consult Factory for Pricing		
(RAM)			
MIC (8X)	Consult Factory for Pricing		
PLD			
MCG	Consult Factory for Pricing		
DAT	Not Available		
MIC			

MARKING FORMAT EXAMPLES

Standard (no Burn-In) Products (Dual-in-line)

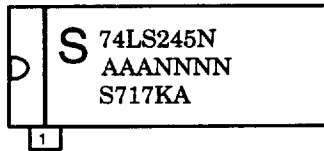

SUPR II (Burned-In) Products (Dual-in-line)

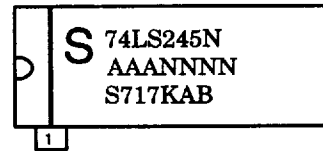

NOTE: The "B" in the 7th position on the 3rd line, when present, is the SUPR II Burn-In indicator.

TAPE AND REEL PACKAGING

SPECIFICATIONS

Tape and Reel specifications conform to Electronic Industries Association (EIA) Proposed Specification #EIA-481-A using 13 inch reels. Current incremental quantities reflect the quantities per reel. As more customers are able to handle a larger quantity per reel, this quantity will be increased.

DEVICE AVAILABILITY

Products available in tape and reel packaging are identified in the Price Book with a "T" suffix to the basic part number and are only offered as a product for sale by the reel. Return of product is limited to full reels with unbroken quality seals.

TAPE AND REEL PRICING ADDERS

PRODUCT FAMILY	SUGGESTED RESALE ADDER
MCG	.07
LIN	.07
LOG	.07
DAT	PACKAGE A28 = .20 A44 = .25 A52 = .30 A68 = .40 A84 = .45 D24 = .17
MIC	

VII. PACKING QUANTITY INFORMATION

T-90-20

CERAMIC DUAL IN-LINE (CERDIP)

PACKAGE CODE	PIN COUNT	QUANTITIES	
		DEVICES PER TUBE	DEVICES PER BOX
F/FE, BPA, PA	8-pin (300-mil)	48	1920
F, BCA, CA	14-pin (300-mil)	25	1000
F, BEA, EA	16-pin (300-mil)	25	1000
F, BVA, MVA	18-pin (300-mil)	21	840
F/FA, BRA, RA	20-pin (300-mil)	20	800
F, BWA, WA	22-pin (400-mil)	17	544
F/FA/F6, BJA, JA	24-pin (600-mil)	15	360
F/FA/F3/F24, BLA, LA	24-pin (300-mil)	15	600
F, BXA, XA	24-pin (400-mil)	15	480
F/FA/F28, BXA, XA	28-pin (600-mil)	13	312
FA	32-pin (600-mil)	11	264
F/FA/F40, BQA, MQA, QA	40-pin (600-mil)	9	216

CERPAC

PACKAGE CODE	PIN COUNT	QUANTITIES
		DEVICES PER TUBE
BDA/DAW	14-pin	145
BFA/FAW	16-pin	145
BXA/BYAW	18-pin	100
BSA/SAW/WB	20-pin	100
BKA/KAW	24-pin	120
BYA/YAW	28-pin	50

CERQUAD

PACKAGE CODE	PIN COUNT	QUANTITIES	
		DEVICES PER TRAY	DEVICES PER BOX
KA/K44	44-pin	6	6
KA/K68	68-pin	4	4
KA	84-pin	42	210

LEADLESS CHIP CARRIER

PACKAGE CODE	PIN COUNT	QUANTITIES
		DEVICES PER TUBE
B2A/2A/GA	20-pin	55
B3A/3A/GA/GC1	28-pin	43
YA/YA/GC2	32-pin	35
BUA/MXA/MUA/UA/XA/GA/GC	44-pin	27
BZA/BUA/UA/ZA/GA/GC	68-pin	19

QUANTITIES SHOWN IN GRAY REQUIRE PURCHASE TO BE MADE IN EXACT MULTIPLES OF THAT QUANTITY.

VII. PACKING QUANTITY INFORMATION

T-90-20

PLASTIC DUAL IN-LINE

PACKAGE CODE	PIN COUNT	QUANTITIES	
		DEVICES PER TUBE	DEVICES PER BOX
N/N8	8-pin (300-mil)	50	2000
N/N14/N16	14- 16-pin (300-mil)	25	1000
N	18-pin (300-mil)	20	800
N/N20	20-pin (300-mil)	18	720
N	22-pin (400-mil)	17	544
N/N6	24-pin (600-mil)	15	360
N/N3/N24	24-pin (300-mil)	15	600
N/N24	24-pin (400-mil)	15	480
N/N28	28-pin (600-mil)	13	312
N/N3	28-pin (300-mil)	13	520
N	32-pin (600-mil)	11	264
N/N40	40-pin (600-mil)	9	216
NB (Shrink)	42-pin (600-mil)	12	288
N/N48	48-pin (600-mil)	7	168
N	50-pin (900-mil)	7	112
N/N64	64-pin (900-mil)	5	80

PLASTIC LEADED CHIP CARRIER (PLCC)

PACKAGE CODE	PIN COUNT	QUANTITIES		
		DEVICES PER TUBE	DEVICES PER BOX	DEVICES PER REEL
A	20-pin	46	3680	1000
A/A28	28-pin	37	2368	750
A	32-pin	31	2232	750
A/A44	44-pin	26	1248	500
A/A52	52-pin	23	1012	500
A/A68	68-pin	18	648	250
A/A84	84-pin	15	420	250

QUANTITIES SHOWN IN GRAY REQUIRE PURCHASE TO BE MADE IN EXACT MULTIPLES OF THAT QUANTITY.

VII. PACKING QUANTITY INFORMATION

T-90-20

PLASTIC SMALL OUTLINE (SO)

PACKAGE CODE	PIN COUNT	QUANTITIES		
		DEVICES PER TUBE	DEVICES PER BOX	DEVICES PER REEL
D/D8	8-pin (150-mil)	100	10000	2500
D	8-pin (300-mil)	64	2560	1000 - 13" 700 - 7"
D/D14	14-pin (150-mil)	57	5700	2500
D	16-pin (150-mil)	50	5000	2500
D	16-pin (300-mil)	48	1920	1000
DK(SSOP)	20-pin (170-mil)	75	6750	2500
D	20-pin (300-mil)	38	1520	1000
D/D24	24-pin (300-mil)	32	1280	1000
D	28-pin (300-mil)	27	1080	1000
D	40-pin (VSO-40)	31	1240	1000 - 13" 300 - 7"
D	56-pin (VSO-56)	22	616	1000

QUAD FLAT PACK*

PACKAGE CODE	PIN COUNT	QUANTITIES	
		DEVICES PER TRAY	DEVICES PER BOX
B/B44	44-pin	50	500
B/B44	44-pin	96	480
B	52-pin	119	595
B	80-pin	66	330
B	100-pin	50	250
B	120-pin	24	120
B	120-pin (Philips source)	30	150

* Quad Flat Pack parts require dry pack handling according to EIA Standard - 583. These parts are identified in part list section with DRY PACK in the Cross Ref Part No field.

QUANTITIES SHOWN IN GRAY REQUIRE PURCHASE TO BE MADE IN EXACT MULTIPLES OF THAT QUANTITY.