



Integrated Device Technology, Inc.

FAST CMOS DUAL 1-OF-4 DECODER WITH ENABLE

IDT54/74FCT139T/AT/CT

FEATURES:

- Std., A and C speed grades
- Low input and output leakage $\leq 1\mu\text{A}$ (max.)
- CMOS power levels
- True TTL input and output compatibility
 - $V_{OH} = 3.3\text{V}$ (typ.)
 - $V_{OL} = 0.3\text{V}$ (typ.)
- High drive outputs (-15mA IOH, 48mA IOL)
- Meets or exceeds JEDEC standard 18 specifications
- Product available in Radiation Tolerant and Radiation Enhanced versions
- Military product compliant to MIL-STD-883, Class B and DESC listed (dual marked)
- Available in DIP, SOIC, QSOP, CERPACK and LCC packages

DESCRIPTION:

The IDT54/74FCT139T/AT/CT are dual 1-of-4 decoders built using an advanced dual metal CMOS technology. These devices have two independent decoders, each of which accept two binary weighted inputs (A_0 - A_1) and provide four mutually exclusive active LOW outputs (\bar{O}_0 - \bar{O}_3). Each decoder has an active LOW enable (\bar{E}). When \bar{E} is HIGH, all outputs are forced HIGH.

FUNCTIONAL BLOCK DIAGRAM

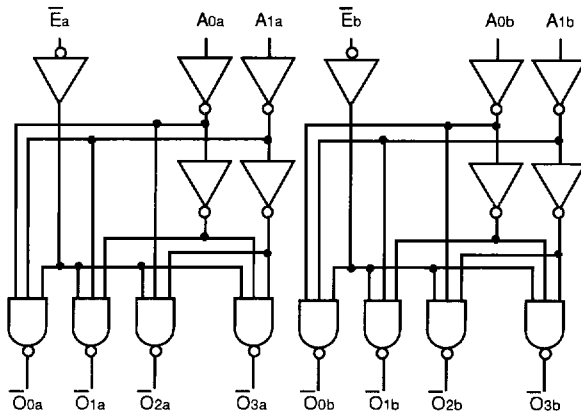

2566 drw 01

PIN CONFIGURATIONS

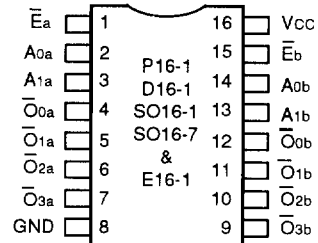

DIP/SOIC/QSOP/CERPACK
TOP VIEW

2566 drw 02

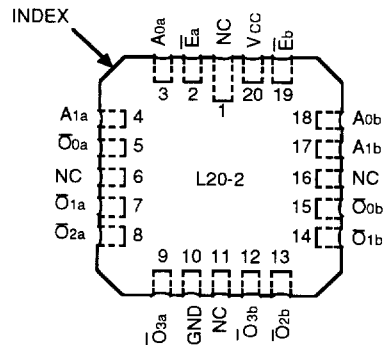

LCC
TOP VIEW

2566 drw 03

The IDT logo is a registered trademark of Integrated Device Technology, Inc.

MILITARY AND COMMERCIAL TEMPERATURE RANGES

APRIL 1994

ABSOLUTE MAXIMUM RATINGS⁽¹⁾

Symbol	Rating	Commercial	Military	Unit
V _{TERM} ⁽²⁾	Terminal Voltage with Respect to GND	-0.5 to +7.0	-0.5 to +7.0	V
V _{TERM} ⁽³⁾	Terminal Voltage with Respect to GND	-0.5 to V _{CC} +0.5	-0.5 to V _{CC} +0.5	V
T _A	Operating Temperature	0 to +70	-55 to +125	°C
T _{BIAS}	Temperature Under Bias	-55 to +125	-65 to +135	°C
T _{STG}	Storage Temperature	-55 to +125	-65 to +150	°C
P _T	Power Dissipation	0.5	0.5	W
I _{OUT}	DC Output Current	-60 to +120	-60 to +120	mA

- NOTES:** 2566 lmk 03
- Stresses greater than those listed under ABSOLUTE MAXIMUM RATINGS may cause permanent damage to the device. This is a stress rating only and functional operation of the device at these or any other conditions above those indicated in the operational sections of this specification is not implied. Exposure to absolute maximum rating conditions for extended periods may affect reliability. No terminal voltage may exceed V_{CC} by +0.5V unless otherwise noted.
 - Input and V_{CC} terminals only.
 - Outputs and I/O terminals only.

PIN DESCRIPTION

Pin Names	Description
A ₀ , A ₁	Address Inputs
E	Enable Input (Active LOW)
O ₀ - O ₃	Outputs (Active LOW)

2566 tbi 01

FUNCTION TABLE⁽¹⁾

Inputs			Outputs			
E	A ₀	A ₁	O ₀	O ₁	O ₂	O ₃
H	X	X	H	H	H	H
L	L	L	L	H	H	H
L	H	L	H	L	H	H
L	L	H	H	H	L	H
L	H	H	H	H	H	L

- NOTE:** 2566 tbi 02
- H = HIGH Voltage Level. L = LOW Voltage Level; X = Don't Care

CAPACITANCE (T_A = +25°C, f = 1.0MHz)

Symbol	Parameter ⁽¹⁾	Conditions	Typ.	Max.	Unit
C _{IN}	Input Capacitance	V _{IN} = 0V	6	10	pF
C _{OUT}	Output Capacitance	V _{OUT} = 0V	8	12	pF

- NOTE:** 2566 lmk 04
- This parameter is measured at characterization but not tested.

DC ELECTRICAL CHARACTERISTICS OVER OPERATING RANGE

Following Conditions Apply Unless Otherwise Specified:

Commercial: T_A = 0°C to +70°C, V_{CC} = 5.0V ± 5%; Military: T_A = -55°C to +125°C, V_{CC} = 5.0V ± 10%

Symbol	Parameter	Test Conditions ⁽¹⁾	Min.	Typ. ⁽²⁾	Max.	Unit
V _{IH}	Input HIGH Level	Guaranteed Logic HIGH Level	2.0	—	—	V
V _{IL}	Input LOW Level	Guaranteed Logic LOW Level	—	—	0.8	V
I _{IH}	Input HIGH Current ⁽⁴⁾	V _{CC} = Max., V _I = 2.7V	—	—	±1	µA
I _{IL}	Input LOW Current ⁽⁴⁾	V _{CC} = Max., V _I = 0.5V	—	—	±1	µA
I _I	Input HIGH Current ⁽⁴⁾	V _{CC} = Max., V _I = V _{CC} (Max.)	—	—	±1	µA
V _{IK}	Clamp Diode Voltage	V _{CC} = Min., I _N = -18mA	—	-0.7	-1.2	V
I _{OS}	Short Circuit Current	V _{CC} = Max. ⁽³⁾ , V _O = GND	-60	-120	-225	mA
V _{OH}	Output HIGH Voltage	V _{CC} = Min., V _{IN} = V _{IH} or V _{IL} , I _{OH} = -6mA MIL.	2.4	3.3	—	V
		I _{OH} = -8mA COM'L., I _{OH} = -12mA MIL., I _{OH} = -15mA COM'L.	2.0	3.0	—	V
V _{OL}	Output LOW Voltage	V _{CC} = Min., V _{IN} = V _{IH} or V _{IL} , I _{OL} = 32mA MIL., I _{OL} = 48mA COM'L.	—	0.3	0.5	V
V _H	Input Hysteresis	—	—	200	—	mV
I _{CC}	Quiescent Power Supply Current	V _{CC} = Max., V _{IN} = GND or V _{CC}	—	0.01	1	mA

- NOTES:** 2566 tbi 05
- For conditions shown as Max. or Min., use appropriate value specified under Electrical Characteristics for the applicable device type.
 - Typical values are at V_{CC} = 5.0V, +25°C ambient and maximum loading.
 - Not more than one output should be shorted at one time. Duration of the short circuit test should not exceed one second.
 - The test limit for this parameter is ±5µA at T_A = -55°C.



POWER SUPPLY CHARACTERISTICS

Symbol	Parameter	Test Conditions ⁽¹⁾		Min.	Typ. ⁽²⁾	Max.	Unit
ΔI_{CC}	Quiescent Power Supply Current TTL Inputs HIGH	$V_{CC} = \text{Max.}$ $V_{IN} = 3.4V^{(3)}$		—	0.5	2.0	mA
I_{CCD}	Dynamic Power Supply Current ⁽⁴⁾	$V_{CC} = \text{Max.}$ Outputs Open One Bit Toggling 50% Duty Cycle	$V_{IN} = V_{CC}$ $V_{IN} = GND$	—	0.15	0.3	mA/ MHz
I_C	Total Power Supply Current ⁽⁶⁾	$V_{CC} = \text{Max.}$ Outputs Open $f_o = 10\text{MHz}$ 50% Duty Cycle One Input and One Output Toggling	$V_{IN} = V_{CC}$ $V_{IN} = GND$	—	1.5	4.0	mA
			$V_{IN} = 3.4V$ $V_{IN} = GND$	—	1.8	5.0	
		$V_{CC} = \text{Max.}$ Outputs Open $f_o = 10\text{MHz}$ 50% Duty Cycle One Input Toggling on Each Decoder Two Outputs Toggling	$V_{IN} = V_{CC}$ $V_{IN} = GND$	—	3.0	7.0 ⁽⁵⁾	
			$V_{IN} = 3.4V$ $V_{IN} = GND$	—	3.5	9.0 ⁽⁵⁾	

NOTES:

- For conditions shown as Max. or Min., use appropriate value specified under Electrical Characteristics for the applicable device type.
- Typical values are at $V_{CC} = 5.0V$, $+25^\circ\text{C}$ ambient.
- Per TTL driven input ($V_{IN} = 3.4V$). All other inputs at V_{CC} or GND.
- This parameter is not directly testable, but is derived for use in Total Power Supply Calculations.
- Values for these conditions are examples of the I_{CC} formula. These limits are guaranteed but not tested.

6. $I_C = I_{QUIESCENT} + I_{INPUTS} + I_{DYNAMIC}$

$I_C = I_{CC} + \Delta I_{CC} D_H N_T + I_{CCD} (f_o N_o)$

$I_{CC} = \text{Quiescent Current}$

$\Delta I_{CC} = \text{Power Supply Current for a TTL High Input } (V_{IN} = 3.4V)$

$D_H = \text{Duty Cycle for TTL Inputs High}$

$N_T = \text{Number of TTL Inputs at } D_H$

$I_{CCD} = \text{Dynamic Current Caused by an Input Transition Pair (HLH or LHL)}$

$f_o = \text{Output Frequency}$

$N_o = \text{Number of Outputs at } f_o$

All currents are in milliamps and all frequencies are in megahertz.

2566 tbl 06

SWITCHING CHARACTERISTICS OVER OPERATING RANGE

Parameter	Description	Condition ⁽¹⁾	FCT139T				FCT139AT				FCT139CT				Unit
			Com'l.		Mil.		Com'l.		Mil.		Com'l.		Mil.		
			Min. ⁽²⁾	Max.	Min. ⁽²⁾	Max.	Min. ⁽²⁾	Max.	Min. ⁽²⁾	Max.	Min. ⁽²⁾	Max.	Min. ⁽²⁾	Max.	
t_{PLH} t_{PHL}	Propagation Delay A ₀ or A ₁ to \bar{O}_n	$C_L = 50\text{pF}$ $R_L = 500\Omega$	1.5	9.0	1.5	12.0	1.5	5.9	1.5	7.8	1.5	5.0	1.5	6.2	ns
t_{PLH} t_{PHL}	Propagation Delay E to \bar{O}_n		1.5	8.0	1.5	9.0	1.5	5.5	1.5	7.2	1.5	4.8	1.5	5.8	

NOTES:

- See test circuit and waveforms.
- Minimum limits are guaranteed but not tested on Propagation Delays.

2566 tbl 07

TEST CIRCUITS AND WAVEFORMS

TEST CIRCUITS FOR ALL OUTPUTS

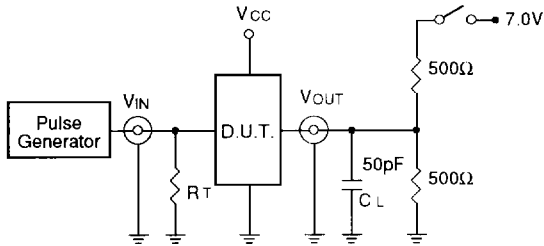

2566 drw 04

SWITCH POSITION

Test	Switch
Open Drain	Closed
Disable Low	
Enable Low	
All Other Tests	Open

2566 Ink 08

DEFINITIONS:

CL = Load capacitance: includes jig and probe capacitance.

RT = Termination resistance: should be equal to Z_{OUT} of the Pulse Generator.

SET-UP, HOLD AND RELEASE TIMES

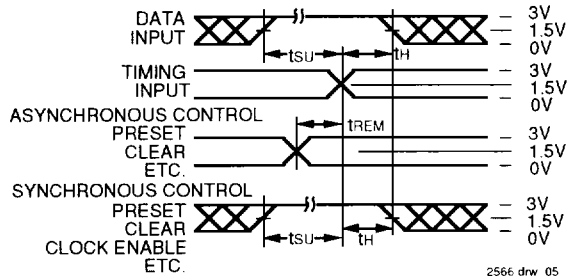

2566 drw 05

PULSE WIDTH

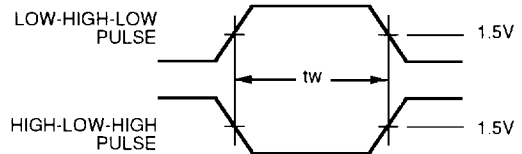

2566 drw 06

PROPAGATION DELAY

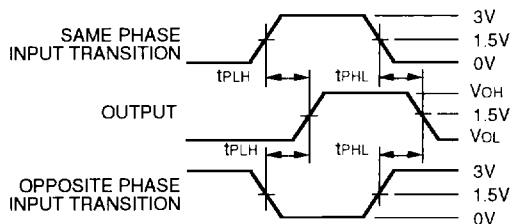

2566 drw 07

ENABLE AND DISABLE TIMES

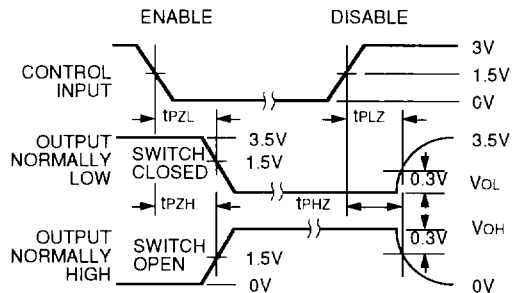

2566 drw 08

NOTES:

- Diagram shown for input Control Enable-LOW and input Control Disable-HIGH
- Pulse Generator for All Pulses: Rate ≤ 1.0MHz; tr ≤ 2.5ns; trs ≤ 2.5ns

ORDERING INFORMATION

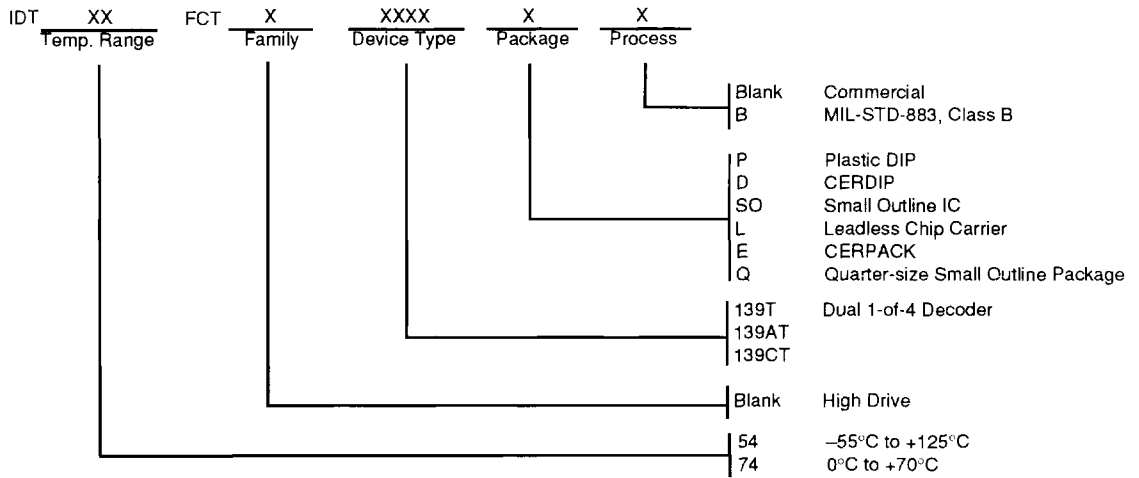

2566 drw 09