

N

## NDS9405 Single P-Channel Enhancement Mode Field Effect Transistor

### General Description

These P-Channel enhancement mode power field effect transistors are produced using National's proprietary, high cell density, DMOS technology. This very high density process is been especially tailored to minimize on-state resistance, provide superior switching performance, and withstand high energy pulses in the avalanche and commutation modes. These devices are particularly suited for low voltage applications such as notebook computer power management and other battery powered circuits where fast switching, low in-line power loss, and resistance to transients are needed.

### Features

- -4.3A, -20V.  $R_{DS(ON)} = 0.10\Omega @ V_{GS} = -10V$
- High density cell design for extremely low  $R_{DS(ON)}$
- High power and current handling capability in a widely used surface mount package.

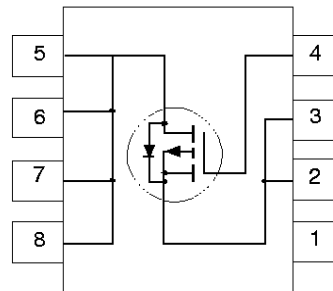
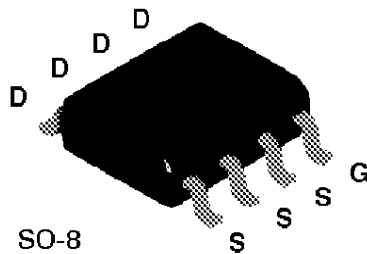

### Absolute Maximum Ratings $T_A = 25^\circ\text{C}$ unless otherwise noted

Symbol	Parameter	NDS9405	Units
$V_{DSS}$	Drain-Source Voltage	-20	V
$V_{GSS}$	Gate-Source Voltage	$\pm 20$	V
$I_D$	Drain Current - Continuous $T_A = 25^\circ\text{C}$ (Note 1a)	$\pm 4.3$	A
	- Continuous $T_A = 70^\circ\text{C}$ (Note 1a)	$\pm 3.3$	
	- Pulsed $T_A = 25^\circ\text{C}$	$\pm 20$	
$P_D$	Maximum Power Dissipation (Note 1a)	2.5	W
	(Note 1b)	1.2	
	(Note 1c)	1	
$T_J, T_{STG}$	Operating and Storage Temperature Range	-55 to 150	$^\circ\text{C}$

### THERMAL CHARACTERISTICS

$R_{\theta JA}$	Thermal Resistance, Junction-to-Ambient (Note 1a)	50	$^\circ\text{C/W}$
$R_{\theta JC}$	Thermal Resistance, Junction-to-Case (Note 1)	25	$^\circ\text{C/W}$

Electrical Characteristics (T <sub>A</sub> = 25 °C unless otherwise noted)						
Symbol	Parameter	Conditions	Min	Typ	Max	Units
<b>OFF CHARACTERISTICS</b>						
BV <sub>DSS</sub>	Drain-Source Breakdown Voltage	V <sub>GS</sub> = 0 V, I <sub>D</sub> = -250 μA	-20			V
I <sub>DSS</sub>	Zero Gate Voltage Drain Current	V <sub>DS</sub> = -16 V, V <sub>GS</sub> = 0 V			-2	μA
		T <sub>J</sub> = 55 °C			-25	μA
I <sub>GSSF</sub>	Gate - Body Leakage, Forward	V <sub>GS</sub> = 20 V, V <sub>DS</sub> = 0 V			100	nA
I <sub>GSSR</sub>	Gate - Body Leakage, Reverse	V <sub>GS</sub> = -20 V, V <sub>DS</sub> = 0 V			-100	nA
<b>ON CHARACTERISTICS</b> (Note 2)						
V <sub>GS(th)</sub>	Gate Threshold Voltage	V <sub>DS</sub> = V <sub>GS</sub> , I <sub>D</sub> = -250 μA	-0.5	-1.65	-3	V
		T <sub>J</sub> = 125 °C	-0.85		-2.6	
R <sub>DS(on)</sub>	Static Drain-Source On-Resistance	V <sub>GS</sub> = -10 V, I <sub>D</sub> = -2 A		0.053	0.1	Ω
		T <sub>J</sub> = 125 °C		0.075	0.15	
		V <sub>GS</sub> = -4.5 V, I <sub>D</sub> = -2 A		0.08	0.16	
		T <sub>J</sub> = 125 °C		0.12	0.24	
I <sub>D(on)</sub>	On-State Drain Current	V <sub>GS</sub> = -10 V, V <sub>DS</sub> = -5 V	-20			A
		V <sub>GS</sub> = -4.5, V <sub>DS</sub> = -5V	-5			
g <sub>FS</sub>	Forward Transconductance	V <sub>DS</sub> = -15 V, I <sub>D</sub> = -4.3 A		9		S
<b>DYNAMIC CHARACTERISTICS</b>						
C <sub>iss</sub>	Input Capacitance	V <sub>DS</sub> = -10 V, V <sub>GS</sub> = 0 V, f = 1.0 MHz		1425		pF
C <sub>oss</sub>	Output Capacitance			850		pF
C <sub>rss</sub>	Reverse Transfer Capacitance			430		pF
<b>SWITCHING CHARACTERISTICS</b> (Note 2)						
t <sub>D(on)</sub>	Turn - On Delay Time	V <sub>DD</sub> = -10 V, I <sub>D</sub> = -1 A, V <sub>GEN</sub> = -10 V, R <sub>GEN</sub> = 6 Ω		17	30	ns
t <sub>r</sub>	Turn - On Rise Time			24	80	ns
t <sub>D(off)</sub>	Turn - Off Delay Time			56	200	ns
t <sub>f</sub>	Turn - Off Fall Time			30	200	ns
Q <sub>g</sub>	Total Gate Charge	V <sub>DS</sub> = -10 V, I <sub>D</sub> = -4.3 A, V <sub>GS</sub> = -10 V			40	nC
Q <sub>gs</sub>	Gate-Source Charge				5	nC
Q <sub>gd</sub>	Gate-Drain Charge				25	nC

### Electrical Characteristics ( $T_A = 25^\circ\text{C}$ unless otherwise noted)

Symbol	Parameter	Conditions	Min	Typ	Max	Units
<b>DRAIN-SOURCE DIODE CHARACTERISTICS AND MAXIMUM RATINGS</b>						
$I_S$	Maximum Continuous Drain-Source Diode Forward Current				-2.2	A
$V_{SD}$	Drain-Source Diode Forward Voltage	$V_{GS} = 0\text{ V}$ , $I_S = -1.25\text{ A}$ (Note 2)		-0.78	-1.6	V
$t_{rr}$	Reverse Recovery Time	$V_{GS} = 0\text{ V}$ , $I_F = -1.25\text{ A}$ , $dI_F/dt = 100\text{ A}/\mu\text{s}$		80		ns

**Notes**

1  $R_{\theta JA}$  is the sum of the junction-to-case and case-to-ambient thermal resistance where the case thermal reference is defined as the solder mounting surface of the drain pins.  $R_{\theta JC}$  is guaranteed by design while  $R_{\theta CA}$  is determined by the user's board design.

$$P_D(t) = \frac{T_J - T_A}{R_{\theta JA}(t)} = \frac{T_J - T_A}{R_{\theta JC} + R_{\theta CA}(t)} = I_D^2(t) \times R_{DS(on)} @ T_J$$

Typical  $R_{\theta JA}$  using the board layouts shown below on a 4.5"x5" FR-4 PCB in a still air environment

- a 50°C/W when mounted on a 1 in<sup>2</sup> pad of 2oz copper
- b 105°C/W when mounted on a 0.04 in<sup>2</sup> pad of 2oz copper
- c 125°C/W when mounted on a 0.006 in<sup>2</sup> pad of 2oz copper

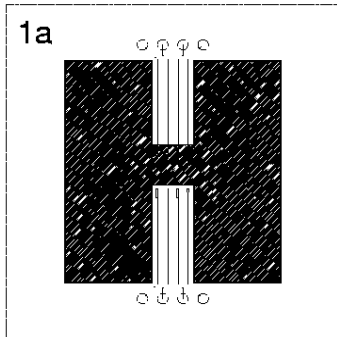

Scale 1:1 on letter size paper

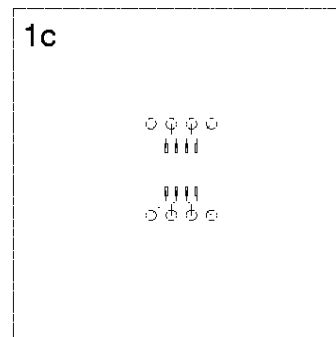
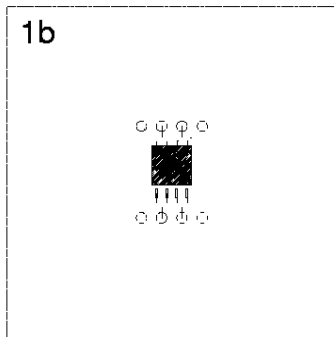

2 Pulse Test: Pulse Width  $\leq 300\mu\text{s}$  Duty Cycle  $\leq 2.0\%$

## Typical Electrical Characteristics

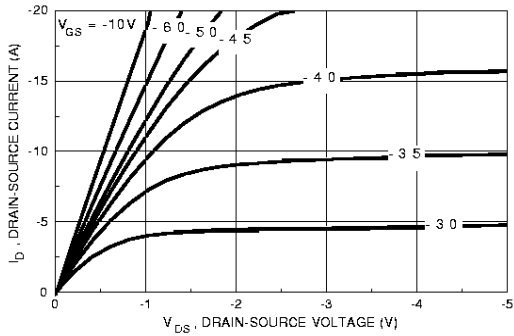

Figure 1. On-Region Characteristics.

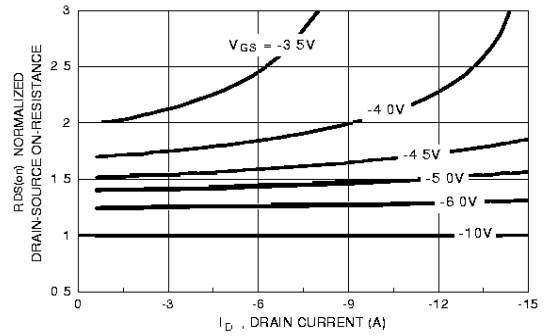

Figure 2. On-Resistance Variation with Drain Current and Gate Voltage.

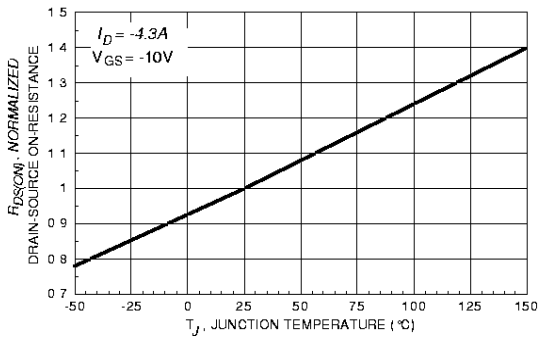

Figure 3. On-Resistance Variation with Temperature.

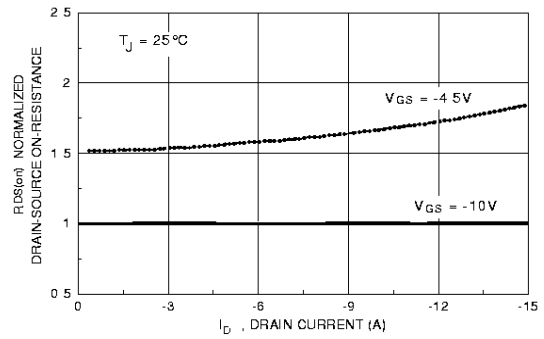

Figure 4. On-Resistance Variation with Drain Current.

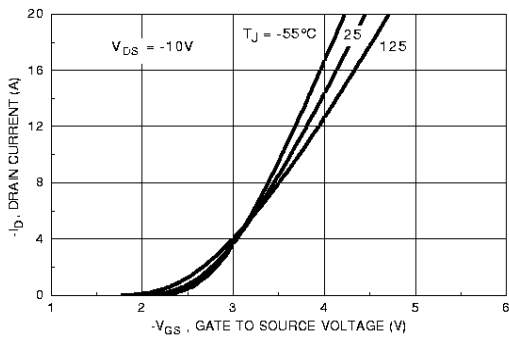

Figure 5. Transfer Characteristics.

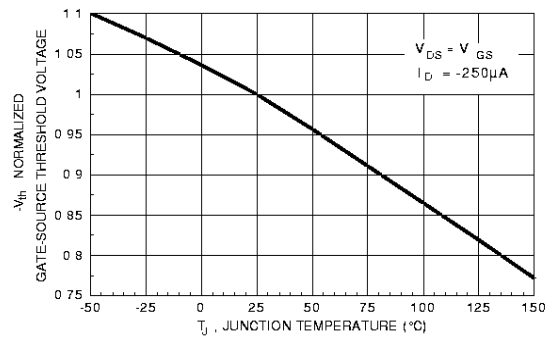
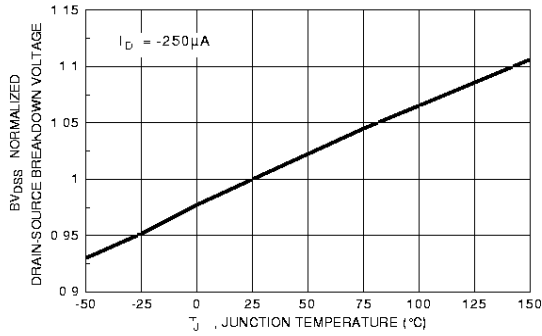
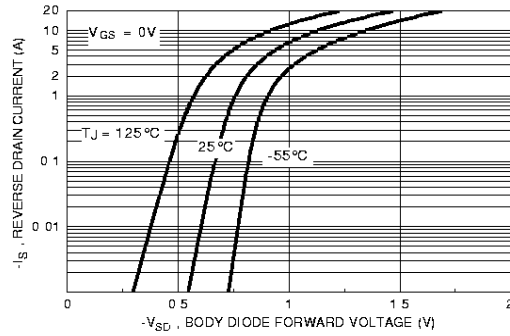

Figure 6. Gate Threshold Variation with Temperature.

## Typical Electrical Characteristics (continued)



**Figure 7. Breakdown Voltage Variation with Temperature.**



**Figure 8. Body Diode Forward Voltage Variation with Source Current and Temperature.**

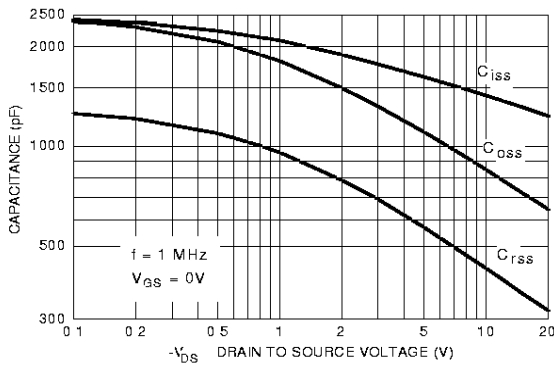

**Figure 9. Capacitance Characteristics.**

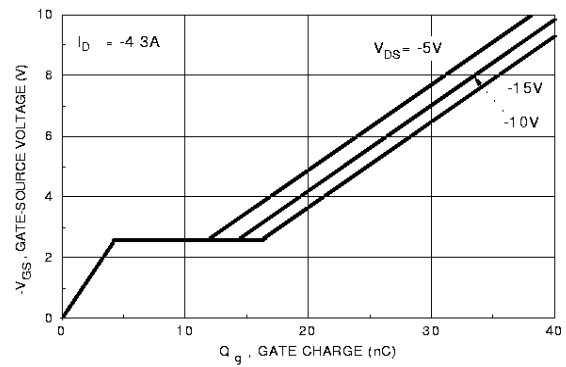

**Figure 10. Gate Charge Characteristics.**

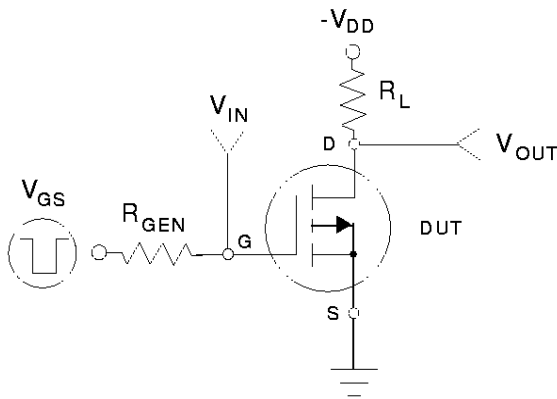

**Figure 11. Switching Test Circuit.**

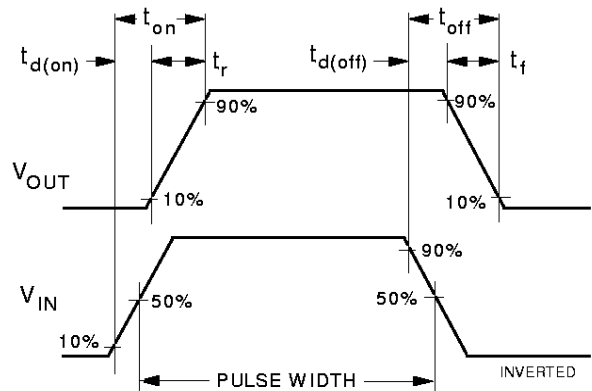

**Figure 12. Switching Waveforms.**

### Typical Electrical Characteristics (continued)

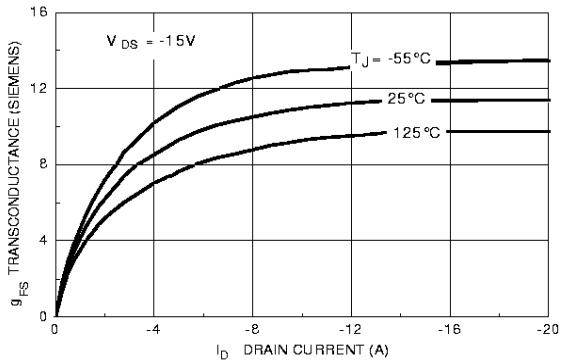

Figure 13. Transconductance Variation with Drain Current and Temperature.

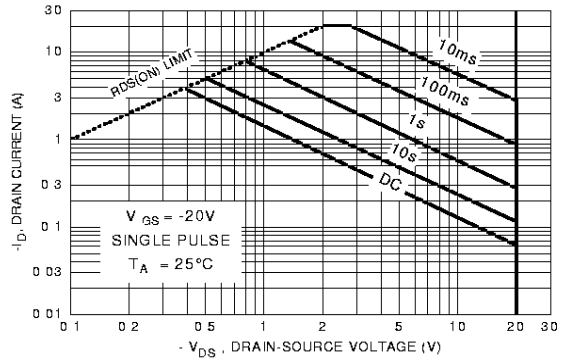

Figure 14. Maximum Safe Operating Area.

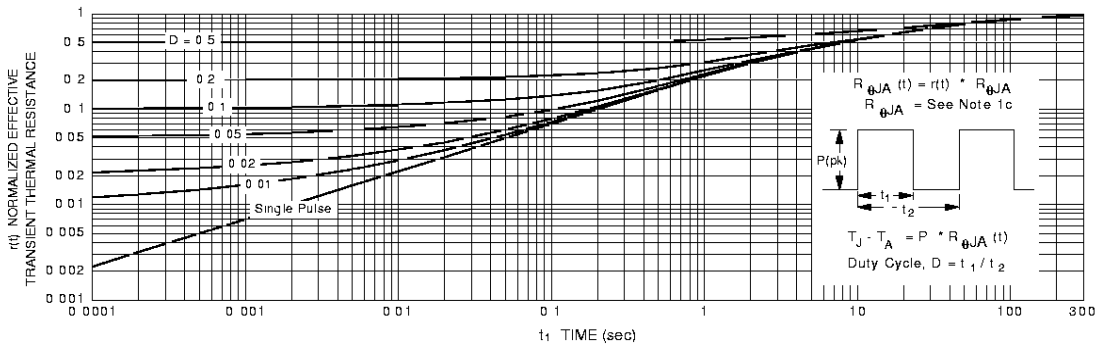

Figure 15. Transient Thermal Response Curve.

Note Thermal characterization performed using the conditions described in note 1c. Transient thermal response will change depending on the circuit board design.