



DATA SHEET

PS200R~PS2010R

FAST SWITCHING PLASTIC RECTIFIER

VOLTAGE 50 to 1000 Volts

CURRENT 2.0 Amperes

DO-15

Unit: inch(mm)

FEATURES

- High current capability.
- Plastic package has Underwriters Laboratory Flammability Classification 94V-O utilizing Flame Retardant Epoxy Molding Compound.
- Low leakage.
- Exceeds environmental standards of MIL-S-19500/228
- Fast switching for high efficiency.
- Pb free product are available : 99% Sn above can meet Rohs environment substance directive request

MECHANICAL DATA

Case: Molded plastic, DO-15

Terminals: Axial leads, solderable to MIL-STD-202G, Method 208

Polarity: Color Band denotes cathode end

Mounting Position: Any

Weight: 0.0154 ounce, 0.4 gram

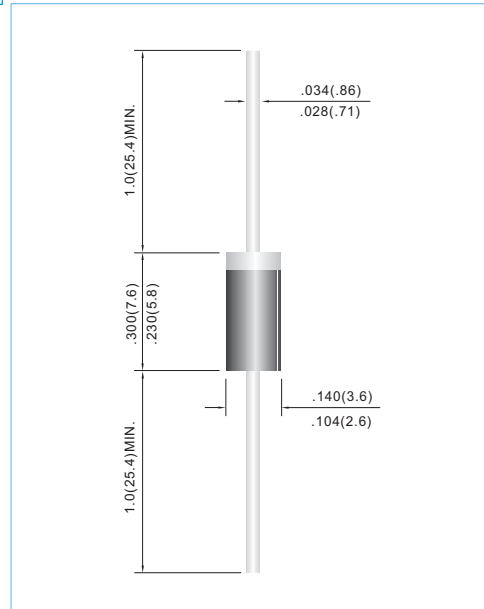

MAXIMUM RATINGS AND ELECTRICAL CHARACTERISTICS

Ratings at 25°C ambient temperature unless otherwise specified. Resistive or inductive load, 60Hz.

PARAMETER	SYMBOL	PS 200R	PS 201R	PS 202R	PS 204R	PS 206R	PS 208R	PS 2010R	UNITS
Maximum Recurrent Peak Reverse Voltage	V_{RRM}	50	100	200	400	600	800	1000	V
Maximum RMS Voltage	V_{RMS}	35	70	140	280	420	560	700	V
Maximum DC Blocking Voltage	V_{DC}	50	100	200	400	600	800	1000	V
Maximum Average Forward Current .375" (9.5mm) lead length at $T_A=55^\circ C$	I_{AV}	2.0							A
Peak Forward Surge Current : 8.3ms single half sine-wave superimposed on rated load (JEDEC method)	I_{FSM}	70							A
Maximum Forward Voltage at 2.0A	V_F	1.3							V
Maximum DC Reverse Current $T_A=25^\circ C$ at Rated DC Blocking Voltage $T_A=100^\circ C$	I_R	5.0 500							μA
Maximum Reverse Recovery Time (Note 1)	T_{RR}	150				250	500		ns
Typical Junction capacitance (Note 2)	C_J	35							pF
Typical Thermal Resistance (Note 3)	$R_{\theta JA}$	40							$^\circ C / W$
Operating Junction and Storage Temperature Range	T_J, T_{STG}	-55 TO +150							$^\circ C$

NOTES: 1. Reverse Recovery Test Conditions: $I_F=.5A$, $I_R=1A$, $I_{rr}=.25A$

2. Measured at 1 MHz and applied reverse voltage of 4.0 VDC

3. Thermal resistance from junction to ambient at 0.375" (9.5mm) lead length with both leads equally heatsink.



RATING AND CHARACTERISTIC CURVES

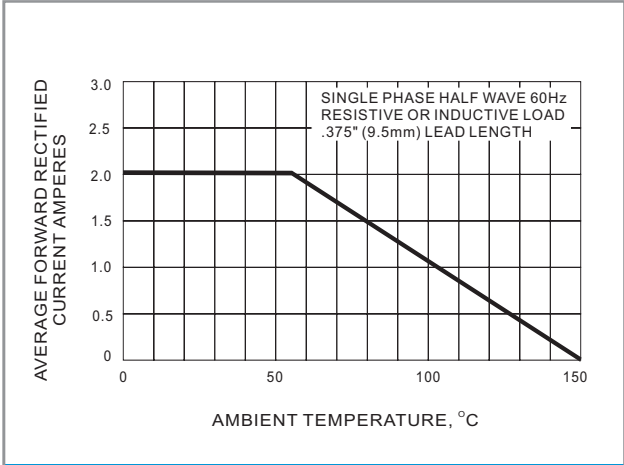

FIG.1 FORWARD CURRENT DERATING CURVE

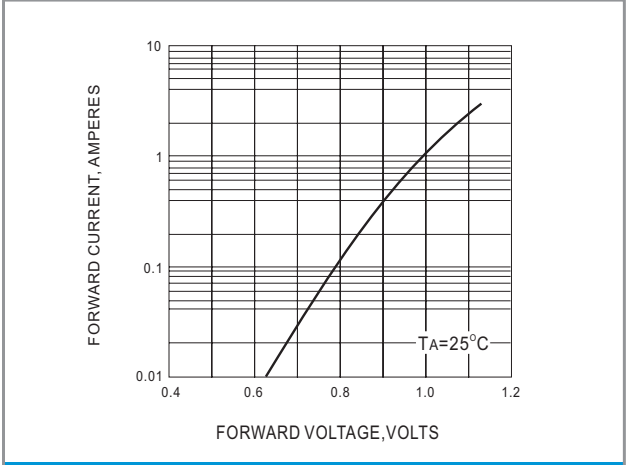

FIG.2 TYPICAL FORWARD CHARACTERISTICS

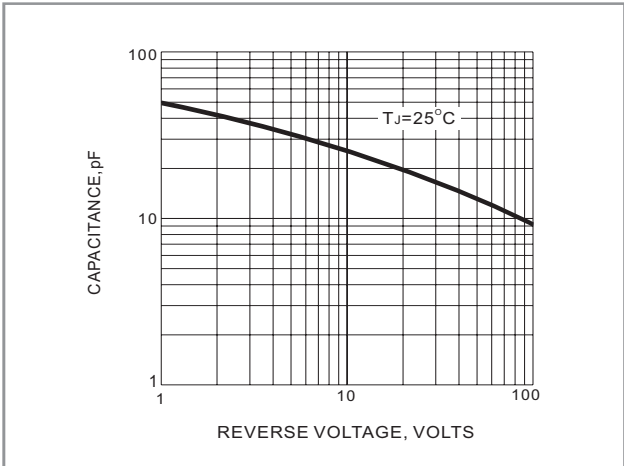

FIG.3 TYPICAL JUNCTION CAPACITANCE

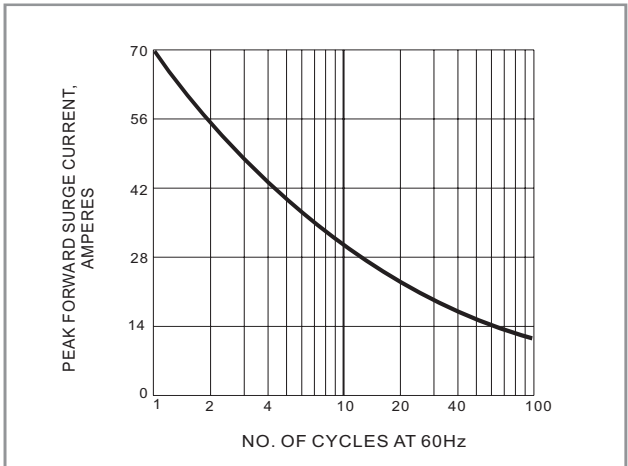

FIG.4 MAX NON-REPETITIVE SURGE CURRENT