

Low I_Q , Low Dropout 560mA Fixed Voltage Regulator

Features

- Low Quiescent Current : 60 μ A (No load)
- Low Dropout Voltage : 600mV (@560mA)
- Very low Shutdown Current : < 0.5 μ A
- Fixed Output Voltage : 1.5V ~ 4.5V
by Step 0.1V Increment
- Stable with Aluminum, Tantalum or Ceramic Capacitors
- No Protection Diodes Needed
- Built in Thermal Protection
- Built in Current Limit Protection
- Controlled Short Circuit Current : 50mA
- Fast Transient Response
- SOT-23, SOT-89 and SOT-223 Packages
- Lead Free and Green Devices Available
(RoHS Compliant)

General Description

The APL5508/5508R/5509/5509R is low-power and low dropout linear regulator, which operates in the range of 2.7V to 6V input voltage and delivers up to 560mA output current. Typical dropout voltage is only 600mV (typical) at 560mA output current. The APL5508/5508R/5509/5509R regulator with low 60 μ A quiescent current is ideal for battery powered system appliances. The APL5508/5508R/5509/5509R regulator is stable with a 4.7 μ F ceramic capacitor. The features of current limit, short circuit current limit, and over-temperature protection protect the device against current over loads and over temperature. The APL5508/5508R/5509/5509R regulator is available in SOT-23, SOT-89, or SOT-223 packages.

Applications

- 5V to 3.3~4.3V Linear Regulators
- 3.3V to 1.5~2.5V Linear Regulators
- CD-R/W, DVD Player
- LAN Card, ADSL/Cable Modem
- Computers

Pin Configuration

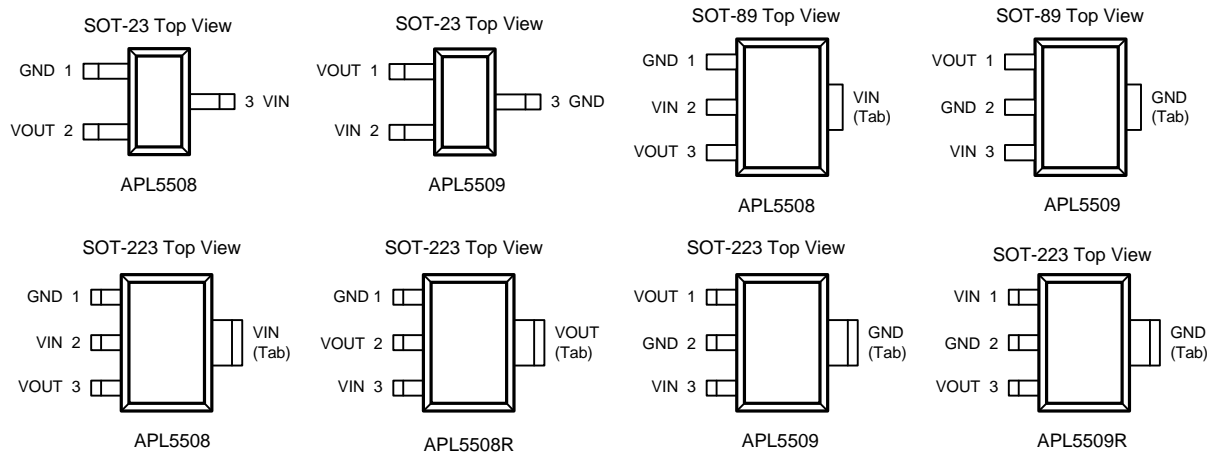

ANPEC reserves the right to make changes to improve reliability or manufacturability without notice, and advise customers to obtain the latest version of relevant information to verify before placing orders.

Ordering and Marking Information

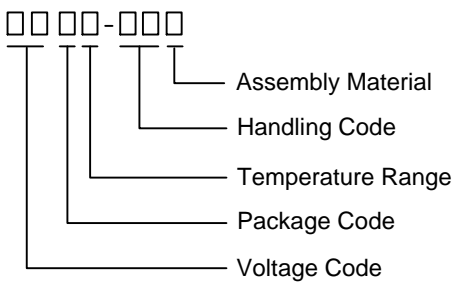
APL5508 APL5508R APL5509 APL5509R		Package Code A : SOT-23 D : SOT-89 V : SOT-223 Temperature Range C : 0 to 70 °C Handling Code TR : Tape & Reel Voltage Code : 15 : 1.5V ~ 45 : 4.5V Assembly Material L : Lead Free Device G : Halogen and Lead Free Device	
APL5508 -15 D/V :	APL5508 XXXXX 15	APL5508R -15 D/V :	APL5508R XXXXX 15
APL5509 -15 D/V :	APL5509 XXXXX 15	APL5509R -15 D/V :	APL5509R XXXXX 15
XXXXX - Date Code ; 15 - 1.5V			

Note: ANPEC lead-free products contain molding compounds/die attach materials and 100% matte tin plate termination finish; which are fully compliant with RoHS. ANPEC lead-free products meet or exceed the lead-free requirements of IPC/JEDEC J-STD-020C for MSL classification at lead-free peak reflow temperature. ANPEC defines "Green" to mean lead-free (RoHS compliant) and halogen free (Br or Cl does not exceed 900ppm by weight in homogeneous material and total of Br and Cl does not exceed 1500ppm by weight).

Marking Information

SOT-23 package

Product Name	Marking	Product Name	Marking	Product Name	Marking	Product Name	Marking
APL5508-15A	589X	APL5508R-15A	58R9X	APL5509-15A	599X	APL5509R-15A	59R9X
APL5508-16A	58AX	APL5508R-16A	58RAX	APL5509-16A	59AX	APL5509R-16A	59RAX
APL5508-17A	58BX	APL5508R-17A	58RBX	APL5509-17A	59BX	APL5509R-17A	59RBX
APL5508-18A	58CX	APL5508R-18A	58RCX	APL5509-18A	59CX	APL5509R-18A	59RCX
APL5508-19A	58DX	APL5508R-19A	58RDX	APL5509-19A	59DX	APL5509R-19A	59RDX
APL5508-20A	58EX	APL5508R-20A	58REX	APL5509-20A	59EX	APL5509R-20A	59REX
APL5508-21A	58FX	APL5508R-21A	58RFX	APL5509-21A	59FX	APL5509R-21A	59RFX
APL5508-22A	58GX	APL5508R-22A	58RGX	APL5509-22A	59GX	APL5509R-22A	59RGX
APL5508-23A	58HX	APL5508R-23A	58RHX	APL5509-23A	59HX	APL5509R-23A	59RHX
APL5508-24A	58IX	APL5508R-24A	58RIX	APL5509-24A	59IX	APL5509R-24A	59RIX
APL5508-25A	58JX	APL5508R-25A	58RJX	APL5509-25A	59JX	APL5509R-25A	59RJX
APL5508-26A	58KX	APL5508R-26A	58RKX	APL5509-26A	59KX	APL5509R-26A	59RKX
APL5508-27A	58LX	APL5508R-27A	58RLX	APL5509-27A	59LX	APL5509R-27A	59RLX
APL5508-28A	58MX	APL5508R-28A	58RMX	APL5509-28A	59MX	APL5509R-28A	59RMX
APL5508-29A	58NX	APL5508R-29A	58RNX	APL5509-29A	59NX	APL5509R-29A	59RNX
APL5508-30A	58OX	APL5508R-30A	58ROX	APL5509-30A	59OX	APL5509R-30A	59ROX
APL5508-31A	58PX	APL5508R-31A	58RPX	APL5509-31A	59PX	APL5509R-31A	59RPX
APL5508-32A	58QX	APL5508R-32A	58RQX	APL5509-32A	59QX	APL5509R-32A	59RQX
APL5508-33A	58RX	APL5508R-33A	58RRX	APL5509-33A	59RX	APL5509R-33A	59RRX
APL5508-34A	58SX	APL5508R-34A	58RSX	APL5509-34A	59SX	APL5509R-34A	59RSX
APL5508-35A	58TX	APL5508R-35A	58RTX	APL5509-35A	59TX	APL5509R-35A	59RTX
APL5508-43A	58UX	APL5508R-43A	58RUX	APL5509-43A	59UX	APL5509R-43A	59RUX
APL5508-45A	58VX	APL5508R-45A	58RVX	APL5509-45A	59VX	APL5509R-45A	59RVX

The last character "X" in the marking is for data code.

Pin Description

PIN		Function
NO.	NAME	
1	VIN	Input Supply Pin. Provides power to the IC, V_{IN} can range from 2.7V to 6V and should be bypassed with at least a 1 μ F capacitor to GND.
2	GND	Ground. Solder to a large ground plane for heatsinking.
3	VOUT	LDO Output. Sources up to 560mA. Bypass with at least a 4.7 μ F capacitor to GND.

Absolute Maximum Ratings

Symbol	Parameter	Rating	Unit
V_{IN}, V_{OUT}	Input Voltage, Output Voltage	6.5	V
$R_{TH,JA}$	Thermal Resistance – Junction to Ambient	SOT-23 : 260 SOT-89 : 180 SOT-223 : 135	$^{\circ}$ C/W
$R_{TH,JC}$	Thermal Resistance – Junction to Case	SOT-23 : 130 SOT-89 : 60 SOT-223 : 40	$^{\circ}$ C/W
P_D	Power Dissipation	Internally Limited	W
T_J	Junction Temperature	150	$^{\circ}$ C
T_{STG}	Storage Temperature Range	-65 to +150	$^{\circ}$ C
T_L	Lead Temperature (Soldering, 10 second)	260	$^{\circ}$ C

Note 1: Stresses beyond the absolute maximum rating may damage the device and operating in the absolute maximum rating conditions may affect device reliability.

Note 2: The maximum allowable power dissipation at any T_A (ambient temperature) is calculated using: $P_D(\text{max}) = (T_J - T_A) / \theta_{JA}$; $T_J = 125^{\circ}$ C. Exceeding the maximum allowable power dissipation will result in excessive die temperature.

Electrical Characteristics

Unless otherwise noted these specifications apply over full temperature, $C_{IN} = 1\mu\text{F}$, $C_{OUT} = 4.7\mu\text{F}$, $T_A = 0$ to 70° C. Typical values refer to $T_A = 25^{\circ}$ C.

Symbol	Parameter	Test Conditions	APL5508/9/R			Unit
			Min.	Typ.	Max.	
V_{IN}	Input Voltage		2.7		6	V
V_{OUT}	Output Voltage	$V_{OUT} + 1.0\text{V} < V_{IN} < 6.0\text{V}$, $0\text{mA} < I_{OUT} < I_{MAX}$	$V_{OUT} - 2\%$	V_{OUT}	$V_{OUT} + 2\%$	V
I_{LIMIT}	Circuit Current Limit	$V_{IN} = V_{OUT} + 1\text{V}$		800		mA
I_{SHORT}	Short Current	$V_{OUT} = 0\text{V}$		50		mA
I_{OUT}	Output Current	$V_{IN} = V_{OUT} + 1\text{V}$	560			mA
REG_{LINE}	Line Regulation	$V_{OUT} + 1\text{V} < V_{IN} < 6.0\text{V}$, $I_{OUT} = 1\text{mA}$		1	10	mV
REG_{LOAD}	Load Regulation	$V_{IN} = V_{OUT} + 1\text{V}$, $0\text{mA} < I_{OUT} < I_{MAX}$		20	40	mV

Electrical Characteristics (Cont.)

Unless otherwise noted these specifications apply over full temperature, $C_{IN} = 1\mu\text{F}$, $C_{OUT} = 4.7\mu\text{F}$, $T_A = 0$ to 70°C . Typical values refer to $T_A = 25^\circ\text{C}$.

Symbol	Parameter	Test Conditions	APL5508/9/R			Unit	
			Min.	Typ.	Max.		
	Load Transient	$V_{IN} = V_{OUT} + 1\text{V}$, $I_{OUT} = 1\text{mA} - 560\text{mA}$ in $1\mu\text{s}$		150	250	mV	
V_{DROP}	Dropout Voltage ^(Note3)	$I_{OUT} = 560\text{mA}$	$1.5\text{V} \leq V_{OUT} < 2.0\text{V}$		1.1	1.3	V
			$2.0\text{V} \leq V_{OUT} < 2.5\text{V}$		0.9	1.0	
			$2.5\text{V} \leq V_{OUT} < 3\text{V}$		0.7	0.8	
			$3\text{V} \leq V_{OUT} \leq 3.5\text{V}$		0.6	0.7	
PSRR	Ripple Rejection	$f \leq 1\text{kHz}$, 1Vpp at $V_{IN} = V_{OUT} + 1.0\text{V}$	45	55		dB	
I_Q	Quiescent Current	No load		60	100	μA	
		$I_{OUT} = 560\text{mA}$		450	500		
OTS	Over Temperature Shutdown			150		$^\circ\text{C}$	
	Over Temperature Hysteresis			30		$^\circ\text{C}$	
TC	Output Voltage Temperature Coefficient			50		ppm/ $^\circ\text{C}$	
T_J	Junction Temperature		0		125	$^\circ\text{C}$	
C_{OUT}	Output Capacitor			4.7		μF	
	ESR		0.01	0.1	1	Ω	

Note3 : Dropout voltage definition : $V_{IN} - V_{OUT}$ when V_{OUT} is 2% below the value of V_{OUT} for $V_{IN} = V_{OUT} + 1\text{V}$.

Typical Application Circuit

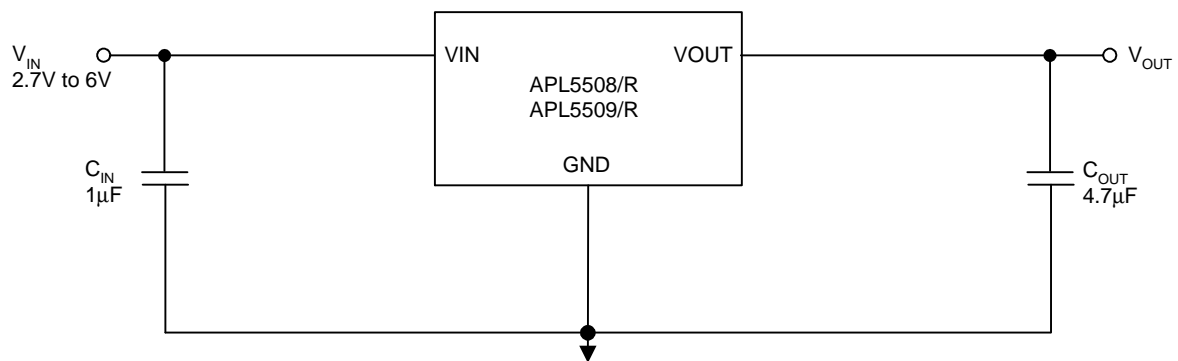

Typical Operating Characteristics

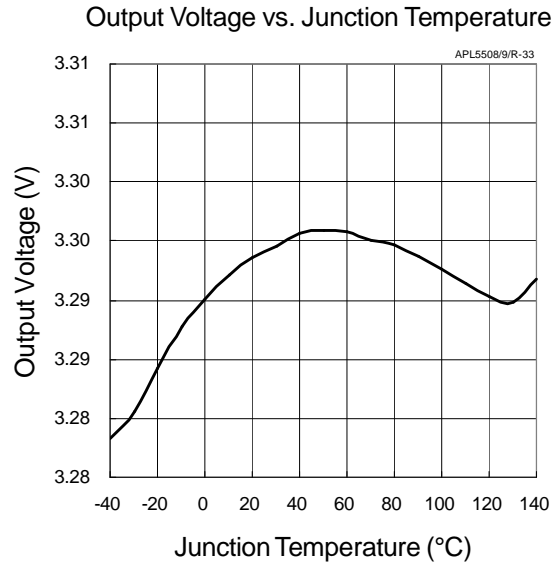
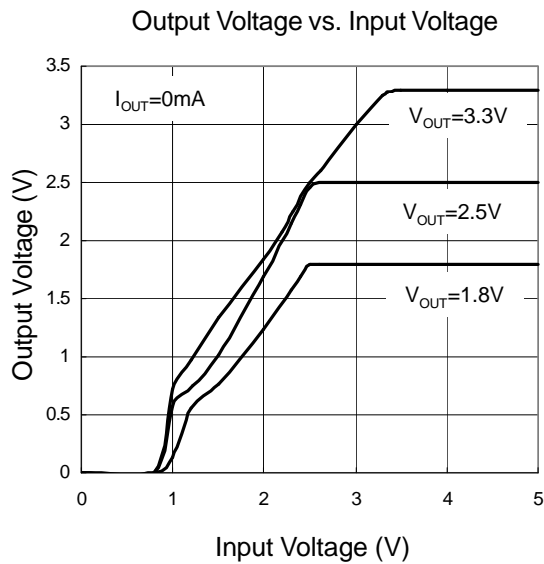
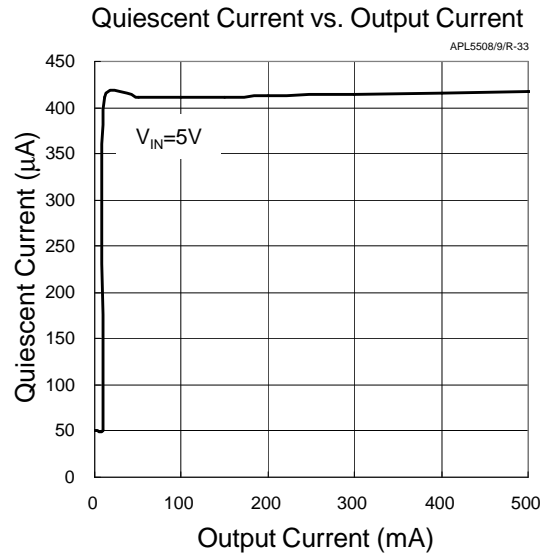
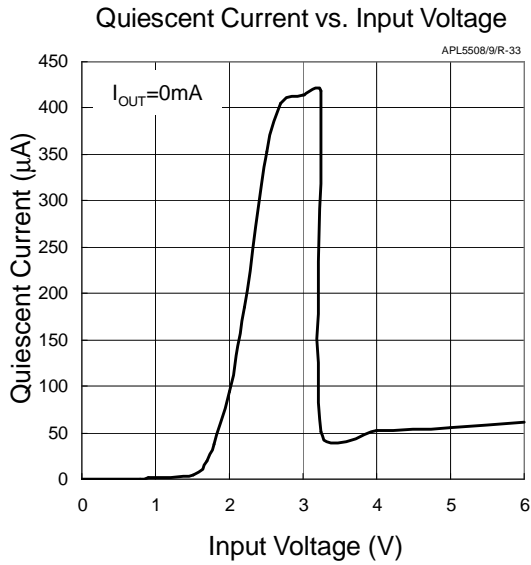

Typical Operating Characteristics (Cont.)

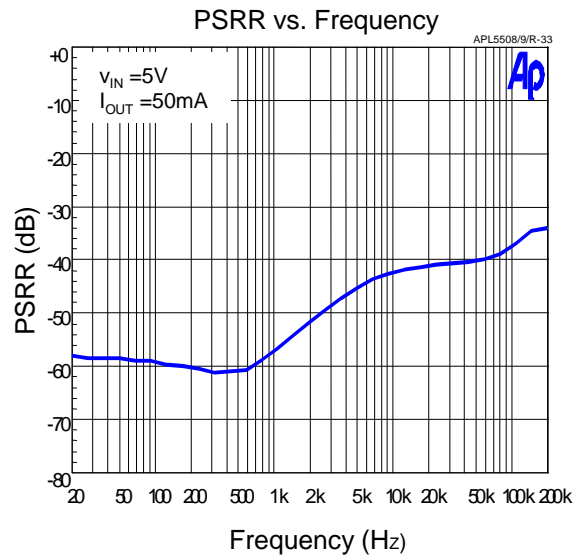
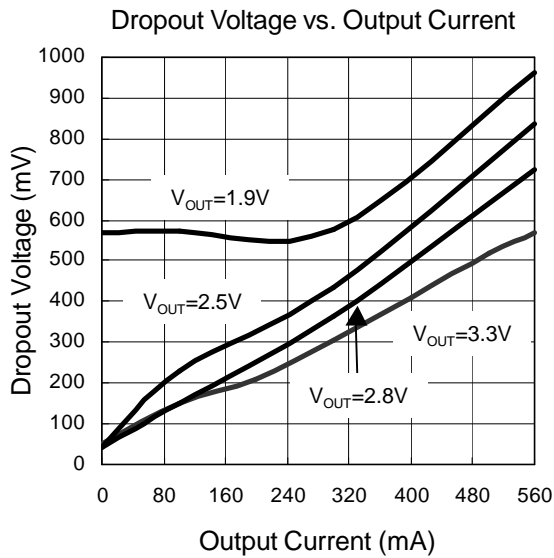
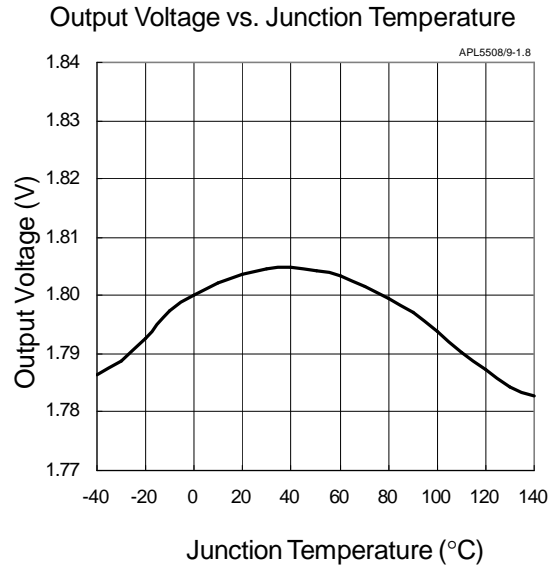
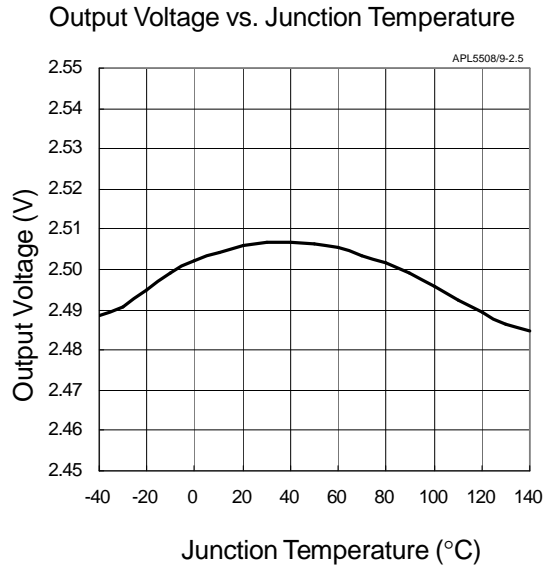

Typical Operating Characteristics (Cont.)

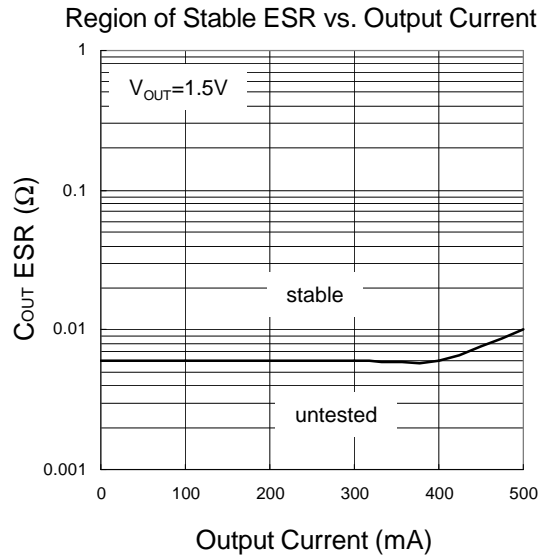
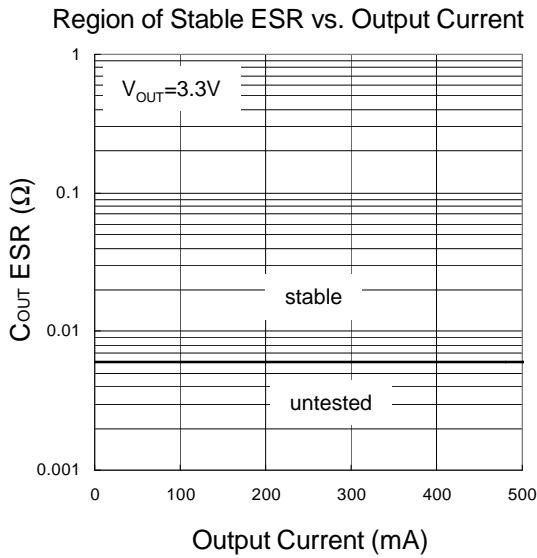
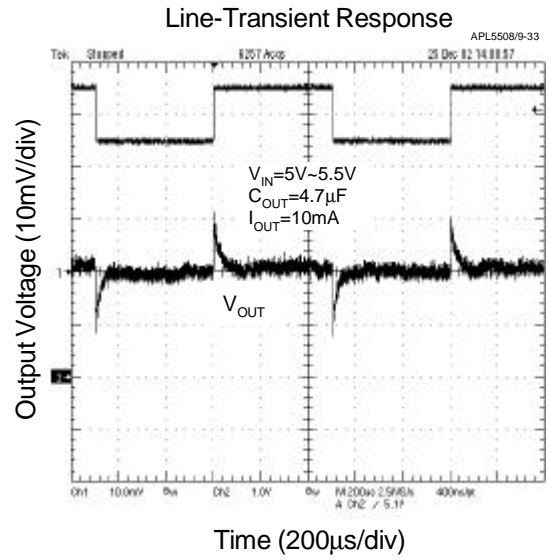
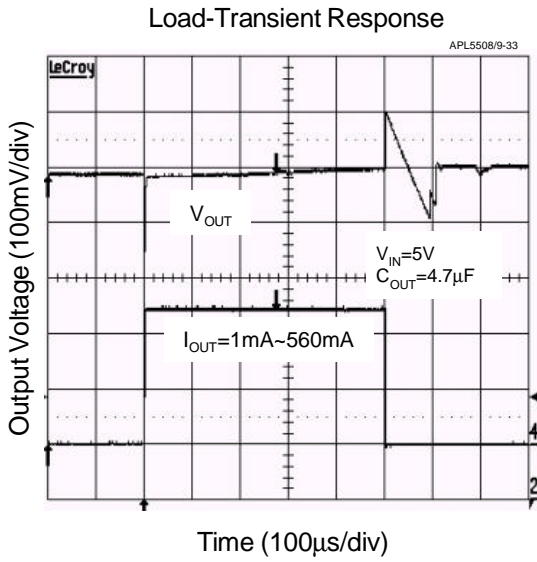

Typical Operating Characteristics (Cont.)

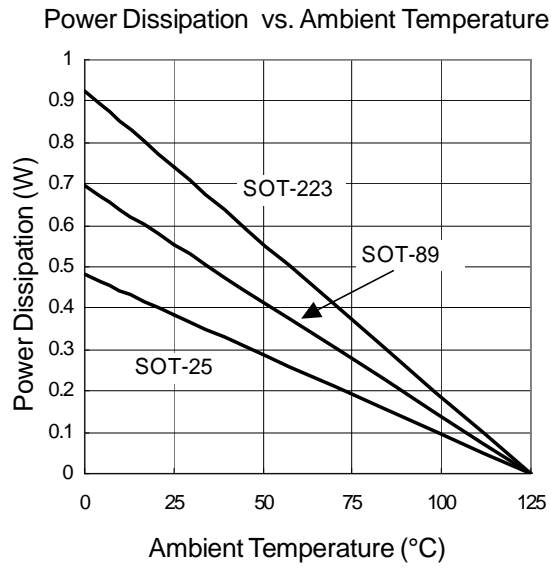

Package Information

SOT-23

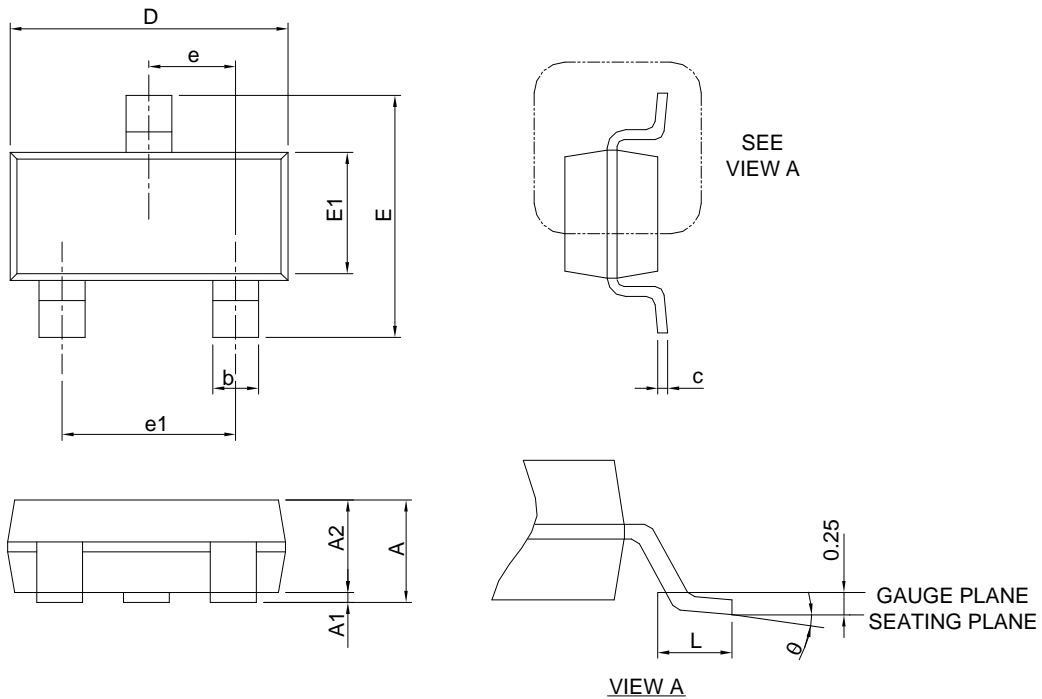

DIMENSIONS	SOT-23			
	MILLIMETERS		INCHES	
	MIN.	MAX.	MIN.	MAX.
A		1.45		0.057
A1	0.00	0.15	0.000	0.006
A2	0.90	1.30	0.035	0.051
b	0.30	0.50	0.012	0.020
c	0.08	0.22	0.003	0.009
D	2.70	3.10	0.106	0.122
E	2.60	3.00	0.102	0.118
E1	1.40	1.80	0.055	0.071
e	0.95 BSC		0.037 BSC	
e1	1.90 BSC		0.075 BSC	
L	0.30	0.60	0.012	0.024
θ	0°	8°	0°	8°

Note : Dimension D and E1 do not include mold flash, protrusions or gate burrs. Mold flash, protrusion or gate burrs shall not exceed 10 mil per side.

Package Information

SOT-89

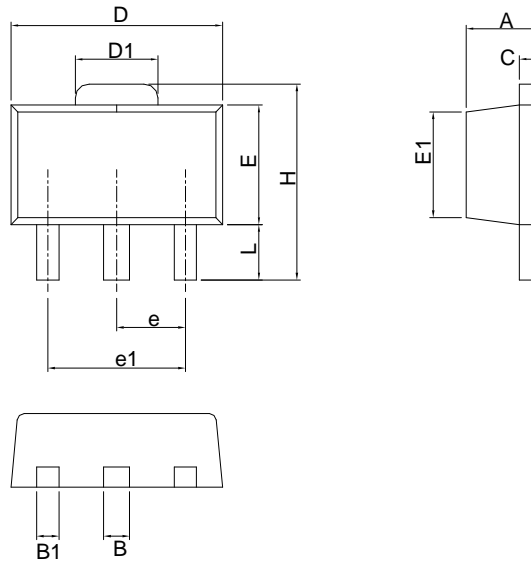

SYMBOL	SOT-89			
	MILLIMETERS		INCHES	
	MIN.	MAX.	MIN.	MAX.
A	1.40	1.60	0.055	0.063
B	0.44	0.56	0.017	0.022
B1	0.36	0.48	0.014	0.019
C	0.35	0.44	0.014	0.017
D	4.40	4.60	0.173	0.181
D1	1.62	1.83	0.064	0.072
E	2.29	2.60	0.090	0.102
E1	2.13	2.29	0.084	0.090
e	1.50 BSC		0.059 BSC	
e1	3.00 BSC		0.118 BSC	
H	3.94	4.25	0.155	0.167
L	0.89	1.20	0.035	0.047

Note : Follow JEDEC TO-243 AA.

Package Information

SOT-223

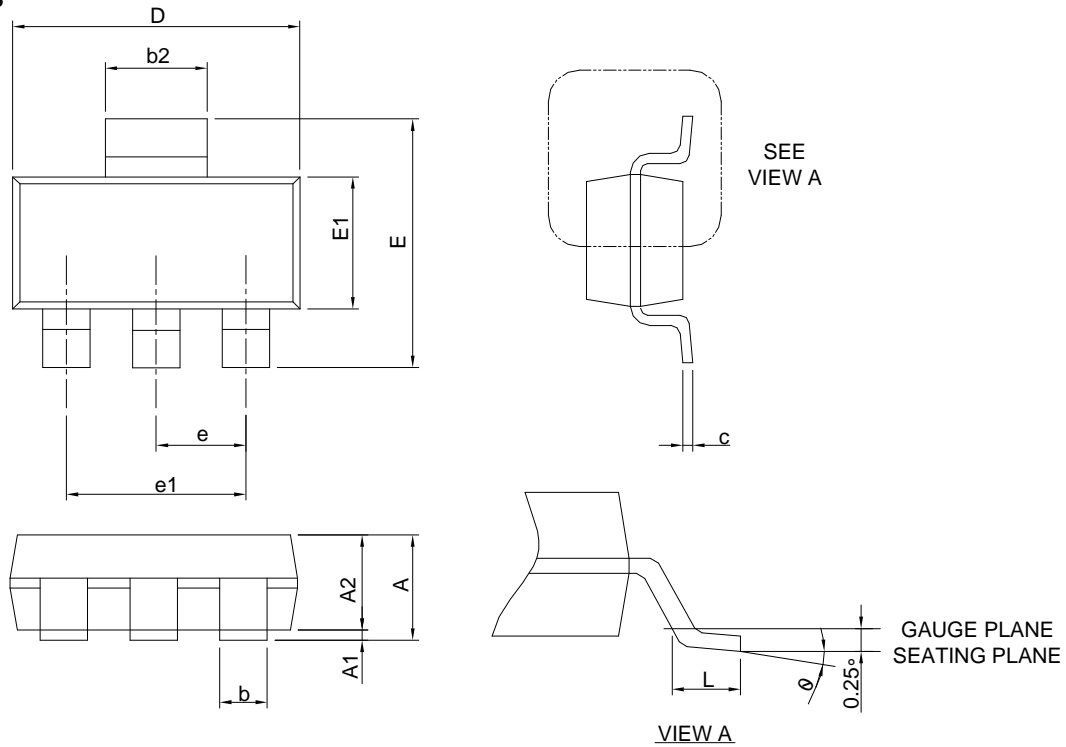

DIMENSIONS	SOT-223			
	MILLIMETERS		INCHES	
	MIN.	MAX.	MIN.	MAX.
A		1.80		0.071
A1	0.02	0.10	0.001	0.004
A2	1.50	1.70	0.059	0.067
b	0.66	0.84	0.026	0.033
b2	2.90	3.10	0.114	0.122
c	0.23	0.33	0.009	0.013
D	6.30	6.70	0.248	0.264
E	6.70	7.30	0.264	0.287
E1	3.30	3.70	0.130	0.146
e	2.30 BSC		0.091 BSC	
e1	4.60 BSC		0.181 BSC	
L	0.75		0.030	
θ	0°	10°	0°	10°

Note : 1. Follow from JEDEC TO-261 AA.
 2. Dimension D and E1 are determined at the outermost extremes of the plastic exclusive of mold flash, tie bar burrs, gate burrs, and interlead flash, but including any mismatch between the top and bottom of the plastic body.

Carrier Tape & Reel Dimensions

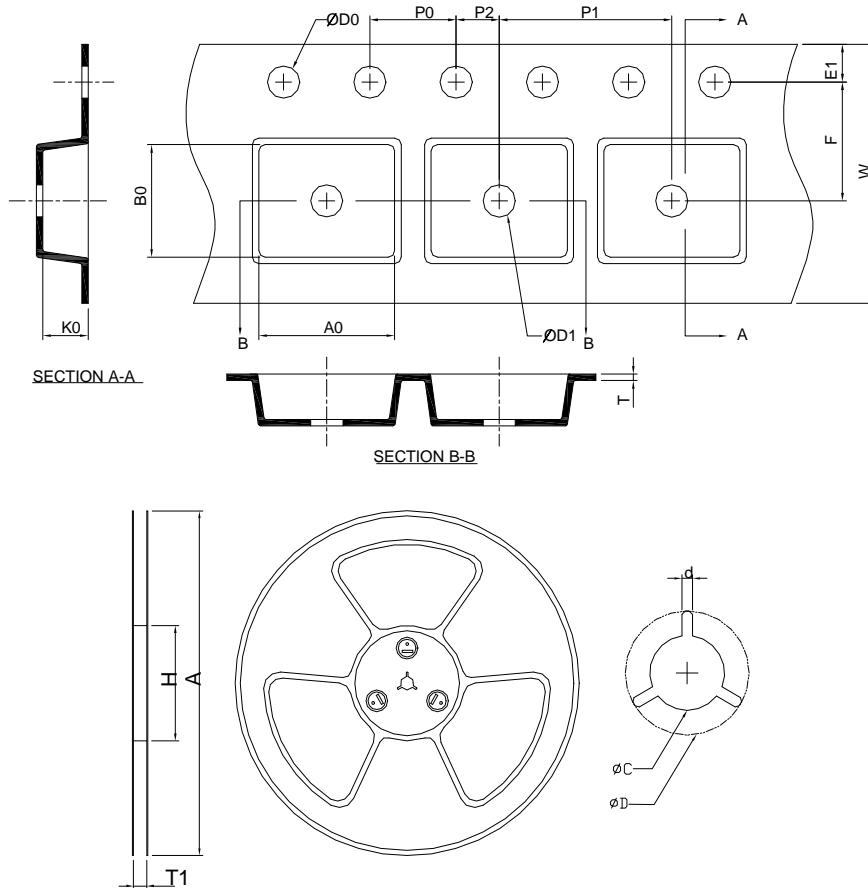

Application	A	H	T1	C	d	D	W	E1	F
SOT-23	178.0 ±2.00	50 MIN.	8.4+2.00 -0.00	13.0+0.50 -0.20	1.5 MIN.	20.2 MIN.	8.0 ±0.30	1.75 ±0.10	3.5 ±0.05
	P0	P1	P2	D0	D1	T	A0	B0	K0
	4.0 ±0.10	4.0 ±0.10	2.0 ±0.10	1.5+0.10 -0.00	1.5 MIN.	0.6+0.00 -0.40	3.20 ±0.20	3.10 ±0.20	1.50 ±0.20
Application	A	H	T1	C	d	D	W	E1	F
SOT-89	178.0 ±2.00	50 MIN.	8.4+2.00 -0.00	13.0+0.50 -0.20	1.5 MIN.	20.2 MIN.	12.0 ±0.30	1.75 ±0.10	5.50 ±0.05
	P0	P1	P2	D0	D1	T	A0	B0	K0
	4.0 ±0.10	8.0 ±0.10	2.0 ±0.10	1.5+0.10 -0.00	1.5 MIN.	0.6+0.00 -0.40	4.80 ±0.20	4.50 ±0.20	1.80 ±0.20
Application	A	H	T1	C	d	D	W	E1	F
SOT-223	320.0 ±2.00	50 MIN.	12.4+2.00 -0.00	13.0+0.50 -0.20	1.5 MIN.	20.2 MIN.	12.00 ±0.30	1.75 ±0.10	5.50 ±0.05
	P0	P1	P2	D0	D1	T	A0	B0	K0
	4.00 ±0.10	8.00 ±0.10	2.00 ±0.50	1.5+0.10 -0.00	1.5 MIN.	0.6+0.00 -0.40	6.90 ±0.20	7.50 ±0.20	2.10 ±0.20

(mm)

Devices Per Unit

Package Type	Unit	Quantity
SOT-23	Tape & Reel	3000
SOT-89	Tape & Reel	1000
SOT-223	Tape & Reel	2500

Reflow Condition (IR/Convection or VPR Reflow)

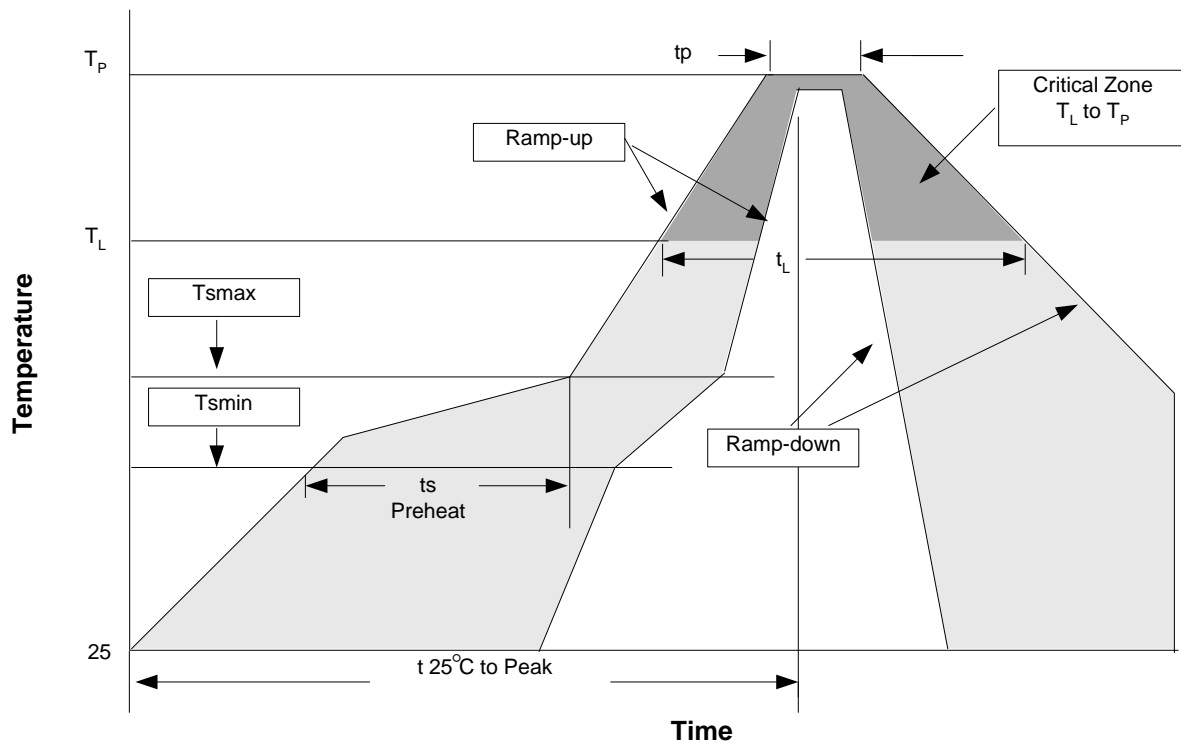

Reliability Test Program

Test item	Method	Description
SOLDERABILITY	MIL-STD-883D-2003	245°C, 5 sec
HOLT	MIL-STD-883D-1005.7	1000 Hrs Bias @125°C
PCT	JESD-22-B,A102	168 Hrs, 100%RH, 121°C
TST	MIL-STD-883D-1011.9	-65°C~150°C, 200 Cycles
ESD	MIL-STD-883D-3015.7	VHBM > 2KV, VMM > 200V
Latch-Up	JESD 78	10ms, $I_{tr} > 100\text{mA}$

Classification Reflow Profiles

Profile Feature	Sn-Pb Eutectic Assembly	Pb-Free Assembly
Average ramp-up rate (T _L to T _P)	3°C/second max.	3°C/second max.
Preheat - Temperature Min (T _{min}) - Temperature Max (T _{max}) - Time (min to max) (ts)	100°C 150°C 60-120 seconds	150°C 200°C 60-180 seconds
Time maintained above: - Temperature (T _L) - Time (t _L)	183°C 60-150 seconds	217°C 60-150 seconds
Peak/Classification Temperature (T _p)	See table 1	See table 2
Time within 5°C of actual Peak Temperature (t _p)	10-30 seconds	20-40 seconds
Ramp-down Rate	6°C/second max.	6°C/second max.
Time 25°C to Peak Temperature	6 minutes max.	8 minutes max.

Note: All temperatures refer to topside of the package. Measured on the body surface.

Table 1. SnPb Eutectic Process – Package Peak Reflow Temperatures

Package Thickness	Volume mm ³ <350	Volume mm ³ ≥350
<2.5 mm	240 +0/-5°C	225 +0/-5°C
≥2.5 mm	225 +0/-5°C	225 +0/-5°C

Table 2. Pb-free Process – Package Classification Reflow Temperatures

Package Thickness	Volume mm ³ <350	Volume mm ³ 350-2000	Volume mm ³ >2000
<1.6 mm	260 +0°C*	260 +0°C*	260 +0°C*
1.6 mm – 2.5 mm	260 +0°C*	250 +0°C*	245 +0°C*
≥2.5 mm	250 +0°C*	245 +0°C*	245 +0°C*

* Tolerance: The device manufacturer/supplier **shall** assure process compatibility up to and including the stated classification temperature (this means Peak reflow temperature +0°C. For example 260°C+0°C) at the rated MSL level.

Customer Service

Anpec Electronics Corp.

Head Office :

No.6, Dusing 1st Road, SBIP,
Hsin-Chu, Taiwan, R.O.C.
Tel : 886-3-5642000
Fax : 886-3-5642050

Taipei Branch :

2F, No. 11, Lane 218, Sec 2 Jhongsing Rd.,
Sindian City, Taipei County 23146, Taiwan
Tel : 886-2-2910-3838
Fax : 886-2-2917-3838