



Integrated Device Technology, Inc.

# FAST CMOS OCTAL REGISTERED TRANSCEIVERS

IDT29FCT52A/B/C  
IDT29FCT53A/B/C

## FEATURES:

- Equivalent to AMD's Am2952/53 and National's 29F52/53 in pinout/function
- IDT29FCT52A/53A equivalent to FAST™ speed
- **IDT29FCT52B/53B 25% faster than FAST**
- **IDT29FCT52C/53C 37% faster than FAST**
- I<sub>OL</sub> = 64mA (commercial) and 48mA (military)
- I<sub>IH</sub> and I<sub>IL</sub> only 5μA max.
- CMOS power levels (2.5mW typ. static)
- TTL input and output level compatible
- CMOS output level compatible
- Available in 24-pin DIP, SOIC, 28-pin LCC with JEDEC standard pinout
- Product available in Radiation Tolerant and Radiation Enhanced versions
- Military product compliant to MIL-STD-883, Class B

## DESCRIPTION:

The IDT29FCT52A/B/C and IDT29FCT53A/B/C are 8-bit registered transceivers manufactured using an advanced dual metal CMOS technology. Two 8-bit back-to-back registers store data flowing in both directions between two bidirectional buses. Separate clock, clock enable and 3-state output enable signals are provided for each register. Both A outputs and B outputs are guaranteed to sink 64mA.

The IDT29FCT52A/B/C is a non-inverting option of the IDT29FCT53A/B/C.

## FUNCTIONAL BLOCK DIAGRAM<sup>(1)</sup>

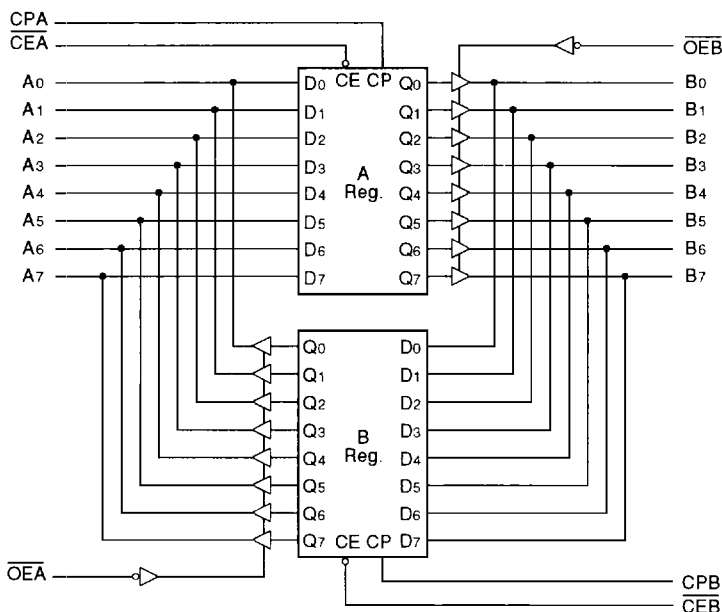

### NOTE:

1. IDT29FCT52 function is shown.

2533 drw 01

7

The IDT logo is a registered trademark of Integrated Device Technology, Inc.  
FAST is a trademark of National Semiconductor Co.

MILITARY AND COMMERCIAL TEMPERATURE RANGES

MAY 1992

**PIN CONFIGURATIONS**

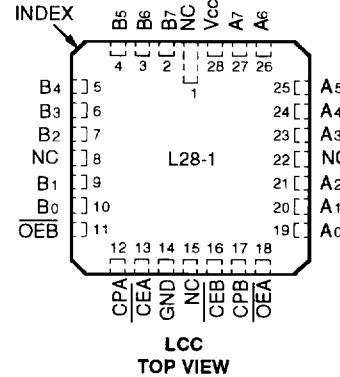
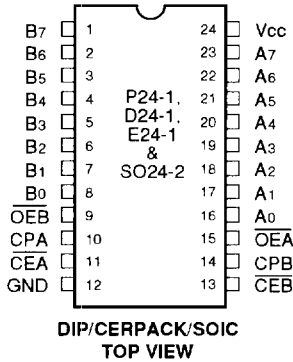

2533 drw 02

**PIN DESCRIPTION**

Name	I/O	Description
A0-7	I/O	Eight bidirectional lines carrying the A Register inputs or B Register outputs.
B0-7	I/O	Eight bidirectional lines carrying the B Register inputs or A Register outputs.
CPA	I	Clock for the A Register. When $\overline{CEA}$ is LOW, data is entered into the A Register on the LOW-to-HIGH transition of the CPA signal.
$\overline{CEA}$	I	Clock Enable for the A Register. When $\overline{CEA}$ is LOW, data is entered into the A Register on the LOW-to-HIGH transition of the CPA signal. When $\overline{CEA}$ is HIGH, the A Register holds its contents, regardless of CPA signal transitions.
$\overline{OEB}$	I	Output Enable for the A Register. When $\overline{OEB}$ is LOW, the A Register outputs are enabled onto the B0-7 lines. When $\overline{OEB}$ is HIGH, the B0-7 outputs are in the high-impedance state.
CPB	I	Clock for the B Register. When $\overline{CEB}$ is LOW, data is entered into the B Register on the LOW-to-HIGH transition of the CPB signal.
$\overline{CEB}$	I	Clock Enable for the B Register. When $\overline{CEB}$ is LOW, data is entered into the B Register on the LOW-to-HIGH transition of the CPB signal. When $\overline{CEB}$ is HIGH, the B Register holds its contents, regardless of CPB signal transitions.
$\overline{OEA}$	I	Output Enable for the B Register. When $\overline{OEA}$ is LOW, the B Register outputs are enabled onto the A0-7 lines. When $\overline{OEA}$ is HIGH, the A0-7 outputs are in the high-impedance state.

2533 tbl 01

**REGISTER FUNCTION TABLE<sup>(1)</sup>**  
(Applies to A or B Register)

Inputs			Internal Q	Function
D	CP	$\overline{CE}$		
X	X	H	NC	Hold Data
L	↑	L	L	Load Data
H	↑	L	H	

2533 tbl 02

**OUTPUT CONTROL<sup>(1)</sup>**

$\overline{OE}$	Internal Q	Y-Outputs		Function
		52	53	
H	X	Z	Z	Disable Outputs
L	L	L	H	Enable Outputs
L	H	H	L	

**NOTE:**

- 1. H = HIGH Voltage Level
- L = LOW Voltage Level
- X = Don't Care
- NC = No Change
- ↑ = LOW-to-HIGH Transition

2533 tbl 03

**ABSOLUTE MAXIMUM RATINGS<sup>(1)</sup>**

Symbol	Rating	Commercial	Military	Unit
V <sub>TERM</sub> <sup>(2)</sup>	Terminal Voltage with Respect to GND	-0.5 to +7.0	-0.5 to +7.0	V
V <sub>TERM</sub> <sup>(3)</sup>	Terminal Voltage with Respect to GND	-0.5 to V <sub>CC</sub>	-0.5 to V <sub>CC</sub>	V
T <sub>A</sub>	Operating Temperature	0 to +70	-55 to +125	°C
T <sub>BIAS</sub>	Temperature Under Bias	-55 to +125	-65 to +135	°C
T <sub>STG</sub>	Storage Temperature	-55 to +125	-65 to +150	°C
P <sub>T</sub>	Power Dissipation	0.5	0.5	W
I <sub>OUT</sub>	DC Output Current	120	120	mA

NOTES: 2533 tbl 04

- Stresses greater than those listed under ABSOLUTE MAXIMUM RATINGS may cause permanent damage to the device. This is a stress rating only and functional operation of the device at these or any other conditions above those indicated in the operational sections of this specification is not implied. Exposure to absolute maximum rating conditions for extended periods may affect reliability. No terminal voltage may exceed +0.5V unless otherwise noted.
- Inputs and V<sub>CC</sub> terminals only.
- Outputs and I/O terminals only.

**CAPACITANCE (T<sub>A</sub> = +25°C, f = 1.0MHz)**

Symbol	Parameter <sup>(1)</sup>	Conditions	Typ.	Max.	Unit
C <sub>IN</sub>	Input Capacitance	V <sub>IN</sub> = 0V	6	10	pF
C <sub>I/O</sub>	I/O Capacitance	V <sub>OUT</sub> = 0V	8	12	pF

NOTE: 2533 tbl 05

- This parameter is guaranteed by characterization data and not tested.

**DC ELECTRICAL CHARACTERISTICS OVER OPERATING RANGE**

Following Conditions Apply Unless Otherwise Specified: V<sub>LC</sub> = 0.2V; V<sub>HC</sub> = V<sub>CC</sub> - 0.2V  
Commercial: T<sub>A</sub> = 0°C to +70°C, V<sub>CC</sub> = 5.0V ± 5%; Military: T<sub>A</sub> = -55°C to +125°C, V<sub>CC</sub> = 5.0V ± 10%

Symbol	Parameter	Test Conditions <sup>(1)</sup>	Min.	Typ. <sup>(2)</sup>	Max.	Unit	
V <sub>IH</sub>	Input HIGH Level	Guaranteed Logic HIGH Level	2.0	—	—	V	
V <sub>IL</sub>	Input LOW Level	Guaranteed Logic LOW Level	—	—	0.8	V	
I <sub>IH</sub>	Input HIGH Current (Except I/O Pins)	V <sub>CC</sub> = Max. V <sub>I</sub> = V <sub>CC</sub>	—	—	5	μA	
		V <sub>I</sub> = 2.7V	—	—	5 <sup>(4)</sup>		
I <sub>IL</sub>	Input LOW Current (Except I/O Pins)	V <sub>CC</sub> = Max. V <sub>I</sub> = 0.5V	—	—	-5 <sup>(4)</sup>	μA	
		V <sub>I</sub> = GND	—	—	-5		
I <sub>IH</sub>	Input HIGH Current (I/O Pins Only)	V <sub>CC</sub> = Max. V <sub>I</sub> = V <sub>CC</sub>	—	—	15	μA	
		V <sub>I</sub> = 2.7V	—	—	15 <sup>(4)</sup>		
I <sub>IL</sub>	Input LOW Current (I/O Pins Only)	V <sub>CC</sub> = Max. V <sub>I</sub> = 0.5V	—	—	-15 <sup>(4)</sup>	μA	
		V <sub>I</sub> = GND	—	—	-15		
V <sub>IK</sub>	Clamp Diode Voltage	V <sub>CC</sub> = Min., I <sub>N</sub> = -18mA	—	-0.7	-1.2	V	
I <sub>OS</sub>	Short Circuit Current	V <sub>CC</sub> = Max. <sup>(3)</sup> , V <sub>O</sub> = GND	-60	-120	—	mA	
V <sub>OH</sub>	Output HIGH Voltage	V <sub>CC</sub> = 3V, V <sub>IN</sub> = V <sub>LC</sub> or V <sub>HC</sub> , I <sub>OH</sub> = -32μA	V <sub>HC</sub>	V <sub>CC</sub>	—	V	
		V <sub>CC</sub> = Min. V <sub>IN</sub> = V <sub>IH</sub> or V <sub>IL</sub>	I <sub>OH</sub> = -300μA	V <sub>HC</sub>	V <sub>CC</sub>		—
			I <sub>OH</sub> = -15mA MIL.	2.4	4.0		—
		I <sub>OH</sub> = -24mA COM'L.	2.4	4.0	—		
V <sub>OL</sub>	Output LOW Voltage	V <sub>CC</sub> = 3V, V <sub>IN</sub> = V <sub>LC</sub> or V <sub>HC</sub> , I <sub>OL</sub> = 300μA	—	GND	V <sub>LC</sub>	V	
		V <sub>CC</sub> = Min. V <sub>IN</sub> = V <sub>IH</sub> or V <sub>IL</sub>	I <sub>OL</sub> = 300μA	—	GND		V <sub>LC</sub> <sup>(4)</sup>
			I <sub>OL</sub> = 48mA MIL. <sup>(5)</sup>	—	0.3		0.55
			I <sub>OL</sub> = 64mA COM'L. <sup>(5)</sup>	—	0.3		0.55

NOTES: 2533 tbl 06

- For conditions shown as Max. or Min., use appropriate value specified under Electrical Characteristics for the applicable device type.
- Typical values are at V<sub>CC</sub> = 5.0V, +25°C ambient and maximum loading.
- Not more than one output should be shorted at one time. Duration of the short circuit test should not exceed one second.
- This parameter is guaranteed but not tested.
- These are maximum I<sub>OL</sub> values per output, for 8 outputs turned on simultaneously. Total maximum I<sub>OL</sub> (all outputs) is 512mA for commercial and 384mA for military. Derate I<sub>OL</sub> for number of outputs exceeding 8 turned on simultaneously.



## POWER SUPPLY CHARACTERISTICS

$$V_{LC} = 0.2V; V_{HC} = V_{CC} - 0.2V$$

Symbol	Parameter	Test Conditions <sup>(1)</sup>		Min.	Typ. <sup>(2)</sup>	Max.	Unit
I <sub>CC</sub>	Quiescent Power Supply Current	V <sub>CC</sub> = Max. V <sub>IN</sub> ≥ V <sub>HC</sub> ; V <sub>IN</sub> ≤ V <sub>LC</sub>		—	0.5	1.5	μA
ΔI <sub>CC</sub>	Quiescent Power Supply Current TTL Inputs HIGH	V <sub>CC</sub> = Max. V <sub>IN</sub> = 3.4V <sup>(3)</sup>		—	0.5	2.0	mA
I <sub>CCD</sub>	Dynamic Power Supply Current <sup>(4)</sup>	V <sub>CC</sub> = Max. Outputs Open OE <sub>A</sub> or OE <sub>B</sub> = GND One Input Toggling 50% Duty Cycle	V <sub>IN</sub> ≥ V <sub>HC</sub> V <sub>IN</sub> ≤ V <sub>LC</sub>	—	0.15	0.25	mA/ MHz
I <sub>C</sub>	Total Power Supply Current <sup>(6)</sup>	V <sub>CC</sub> = Max. Outputs Open f <sub>CP</sub> = 10MHz 50% Duty Cycle OE <sub>A</sub> or OE <sub>B</sub> = GND One Bit Toggling at f <sub>i</sub> = 5MHz 50% Duty Cycle	V <sub>IN</sub> ≥ V <sub>HC</sub> V <sub>IN</sub> ≤ V <sub>LC</sub> (FCT)	—	2.0	4.0	mA
			V <sub>IN</sub> = 3.4V V <sub>IN</sub> = GND	—	2.5	6.0	
		V <sub>CC</sub> = Max. Outputs Open f <sub>CP</sub> = 10MHz 50% Duty Cycle OE <sub>A</sub> or OE <sub>B</sub> = GND Eight Bits Toggling at f <sub>i</sub> = 2.5MHz 50% Duty Cycle	V <sub>IN</sub> ≥ V <sub>HC</sub> V <sub>IN</sub> ≤ V <sub>LC</sub> (FCT)	—	4.3	7.8 <sup>(5)</sup>	
			V <sub>IN</sub> = 3.4V V <sub>IN</sub> = GND	—	6.5	16.8 <sup>(5)</sup>	

### NOTES:

2533 tbl 07

- For conditions shown as Max. or Min., use appropriate value specified under Electrical Characteristics for the applicable device type.
- Typical values are at V<sub>CC</sub> = 5.0V, +25°C ambient.
- Per TTL driven input (V<sub>IN</sub> = 3.4V); all other inputs at V<sub>CC</sub> or GND.
- This parameter is not directly testable, but is derived for use in Total Power Supply calculations.
- Values for these conditions are examples of the I<sub>CC</sub> formula. These limits are guaranteed but not tested.
- I<sub>C</sub> = I<sub>QUIESCENT</sub> + I<sub>INPUTS</sub> + I<sub>DYNAMIC</sub>  
 I<sub>C</sub> = I<sub>CC</sub> + ΔI<sub>CC</sub> D<sub>H</sub> N<sub>T</sub> + I<sub>CCD</sub> (f<sub>CP</sub>/2 + f<sub>i</sub> N<sub>i</sub>)  
 I<sub>CC</sub> = Quiescent Current  
 ΔI<sub>CC</sub> = Power Supply Current for a TTL High Input (V<sub>IN</sub> = 3.4V)  
 D<sub>H</sub> = Duty Cycle for TTL Inputs High  
 N<sub>T</sub> = Number of TTL Inputs at D<sub>H</sub>  
 I<sub>CCD</sub> = Dynamic Current Caused by an Output Transition Pair (HLH or LHL)  
 f<sub>CP</sub> = Clock Frequency for Register Devices (Zero for Non-Register Devices)  
 f<sub>i</sub> = Input Frequency  
 N<sub>i</sub> = Number of Inputs at f<sub>i</sub>  
 All currents are in milliamps and all frequencies are in megahertz.

**SWITCHING CHARACTERISTICS OVER OPERATING RANGE**

Symbol	Parameter	Condition <sup>(1)</sup>	IDT29FCT52A/53A				IDT29FCT52B/53B				IDT29FCT52C/53C				Unit
			Com'l.		Mil.		Com'l.		Mil.		Com'l.		Mil.		
			Min. <sup>(2)</sup>	Max.	Min. <sup>(2)</sup>	Max.	Min. <sup>(2)</sup>	Max.	Min. <sup>(2)</sup>	Max.	Min. <sup>(2)</sup>	Max.	Min. <sup>(2)</sup>	Max.	
tPLH tPHL	Propagation Delay CPA, CPB to A <sub>n</sub> , B <sub>n</sub>	CL = 50pF RL = 500Ω	2.0	10.0	2.0	11.0	2.0	7.5	2.0	8.0	2.0	6.3	2.0	7.3	ns
tPZH tPZL	Output Enable Time OE <sub>A</sub> or OE <sub>B</sub> to A <sub>n</sub> or B <sub>n</sub>		1.5	10.5	1.5	13.0	1.5	8.0	1.5	8.5	1.5	7.0	1.5	8.0	ns
tPHZ tPLZ	Output Disable Time OE <sub>A</sub> or OE <sub>B</sub> to A <sub>n</sub> or B <sub>n</sub>		1.5	10.0	1.5	10.0	1.5	7.5	1.5	8.0	1.5	6.5	1.5	7.5	ns
tSU	Set-up Time HIGH or LOW A <sub>n</sub> , B <sub>n</sub> to CPA, CPB		2.5	—	2.5	—	2.5	—	2.5	—	2.5	—	2.5	—	ns
tH	Hold Time HIGH or LOW A <sub>n</sub> , B <sub>n</sub> to CPA, CPB		2.0	—	2.0	—	1.5	—	1.5	—	1.5	—	1.5	—	ns
tSU	Set-up Time HIGH or LOW CE <sub>A</sub> , CE <sub>B</sub> to CPA, CPB		3.0	—	3.0	—	3.0	—	3.0	—	3.0	—	3.0	—	ns
tH	Hold Time HIGH or LOW CE <sub>A</sub> , CE <sub>B</sub> to CPA, CPB		2.0	—	2.0	—	2.0	—	2.0	—	2.0	—	2.0	—	ns
tW	Pulse Width, HIGH <sup>(3)</sup> or LOW CPA or CPB		3.0	—	3.0	—	3.0	—	3.0	—	3.0	—	3.0	—	ns

**NOTES:**

1. See test circuit and waveforms.
2. Minimum limits are guaranteed but not tested on Propagation Delays.
3. This parameter is guaranteed but not tested.

2533 tbl 08



## TEST CIRCUITS AND WAVEFORMS

### TEST CIRCUITS FOR ALL OUTPUTS

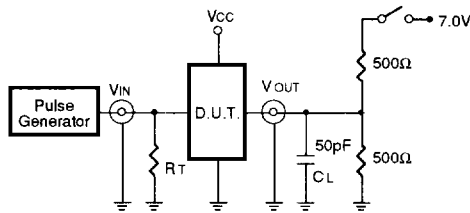

### SWITCH POSITION

Test	Switch
Open Drain Disable Low Enable Low	Closed
All Other Tests	Open

#### DEFINITIONS:

CL = Load capacitance: includes jig and probe capacitance.  
RT = Termination resistance: should be equal to ZOUT of the Pulse Generator.

2533 tbi 05

### SET-UP, HOLD AND RELEASE TIMES

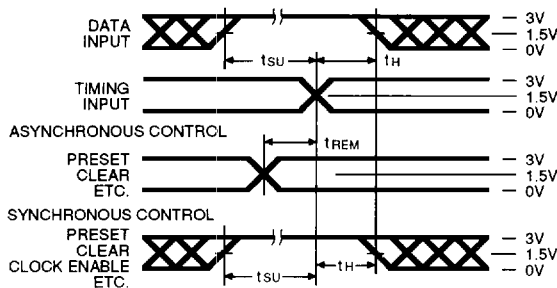

### PULSE WIDTH

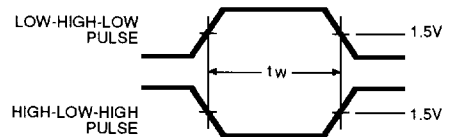

### PROPAGATION DELAY

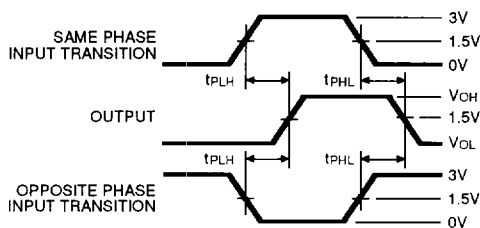

### ENABLE AND DISABLE TIMES

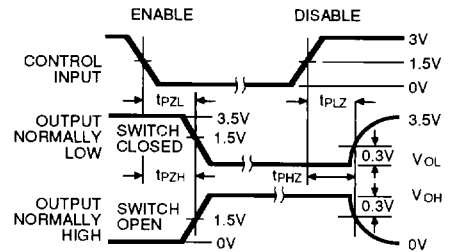

#### NOTES

- Diagram shown for input Control Enable-LOW and input Control Disable-HIGH.
- Pulse Generator for All Pulses: Rate  $\leq 1.0$  MHz;  $Z_0 \leq 50\Omega$ ;  $t_r \leq 2.5$ ns;  $t_r \leq 2.5$ ns.

2533 dnr 04

**ORDERING INFORMATION**

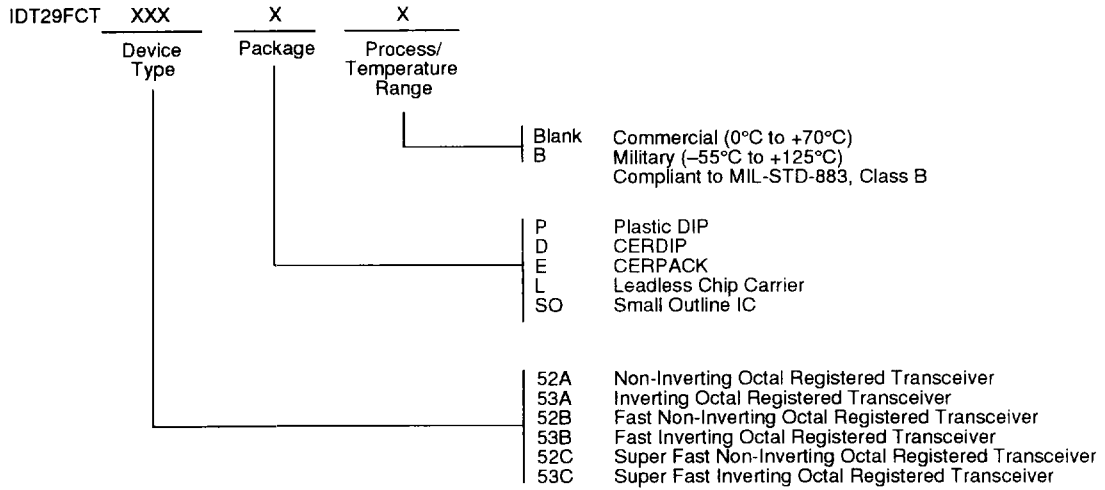

2533 drw 03