



M95256 M95256-W M95256-R

256 Kbit serial SPI bus EEPROM
with high speed clock

Features

- Compatible with SPI bus serial interface (positive clock SPI modes)
- Single supply voltage:
 - 4.5 to 5.5 V for M95256
 - 2.5 to 5.5 V for M95256-W
 - 1.8 to 5.5 V for M95256-R
- High speed
 - 10 MHz clock rate, 5 ms write time
- Status Register
- Hardware protection of the Status Register
- Byte and Page Write (up to 64 bytes)
- Self-timed programming cycle
- Adjustable size read-only EEPROM area
- Enhanced ESD protection
- More than 1,000,000 write cycles
- More than 40-year data retention
- Packages
 - ECOPACK® (RoHS compliant)

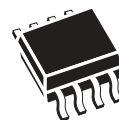

SO8 (MN)
150 mil width

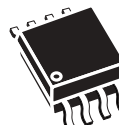

SO8 (MW)
200 mil width

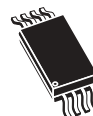

TSSOP8 (DW)
169 mil width

Contents

1	Description	6
2	Memory organization	8
3	Signal description	9
3.1	Serial Data output (Q)	9
3.2	Serial Data input (D)	9
3.3	Serial Clock (C)	9
3.4	Chip Select (\overline{S})	9
3.5	Hold (\overline{HOLD})	9
3.6	Write Protect (\overline{W})	10
3.7	V _{SS} ground	10
3.8	Supply voltage (V _{CC})	10
3.8.1	Operating supply voltage V _{CC}	10
3.8.2	Power-up conditions	10
3.8.3	Device Reset	10
3.8.4	Power-down	11
4	Operating features	11
4.1	Hold condition	11
4.2	Status Register	13
4.3	Data protection and protocol control	13
5	Instructions	14
5.1	Write Enable (WREN)	14
5.2	Write Disable (WRDI)	15
5.3	Read Status Register (RDSR)	16
5.3.1	WIP bit	16
5.3.2	WEL bit	16
5.3.3	BP1, BP0 bits	16
5.3.4	SRWD bit	16
5.4	Write Status Register (WRSR)	18
5.5	Read from Memory Array (READ)	21

5.6	Write to Memory Array (WRITE)	22
5.6.1	ECC (error correction code) and Write cycling	23
6	Delivery state	24
7	Connecting to the SPI bus	24
7.1	SPI modes	25
8	Maximum rating	26
9	DC and AC parameters	27
10	Package mechanical	36
11	Part numbering	39
12	Revision history	41

List of tables

Table 1.	Signal names	7
Table 2.	Write-protected block size	13
Table 3.	Instruction set	14
Table 4.	Status Register format	16
Table 5.	Protection modes	19
Table 6.	Absolute maximum ratings	26
Table 7.	Operating conditions (M95256)	27
Table 8.	Operating conditions (M95256-W)	27
Table 9.	Operating conditions (M95256-R)	27
Table 10.	AC measurement conditions	27
Table 11.	Capacitance	28
Table 12.	DC characteristics (M95256, device grade 3)	28
Table 13.	DC characteristics (M95256-W, device grade 6)	28
Table 14.	DC characteristics (M95256-W, device grade 3)	29
Table 15.	DC characteristics (M95256-R)	29
Table 16.	AC characteristics (M95256, device grade 3)	30
Table 17.	AC characteristics (M95256-W, device grade 6)	31
Table 18.	AC characteristics (M95256-W, device grade 3)	32
Table 19.	AC characteristics (M95256-R)	33
Table 20.	SO8 narrow – 8 lead plastic small outline, 150 mils body width, package mechanical data	36
Table 21.	SO8 wide – 8 lead plastic small outline, 200 mils body width, package mechanical data	37
Table 22.	TSSOP8 – 8 lead thin shrink small outline, package mechanical data	38
Table 23.	Ordering information scheme	39
Table 24.	Available M95256x products (package, voltage range, temperature grade)	40
Table 25.	Document revision history	41

List of figures

Figure 1.	Logic diagram	6
Figure 2.	SO and TSSOP connections	6
Figure 3.	Block diagram	8
Figure 4.	Hold condition activation.	12
Figure 5.	Write Enable (WREN) sequence	14
Figure 6.	Write Disable (WRDI) sequence	15
Figure 7.	Read Status Register (RDSR) sequence	17
Figure 8.	Write Status Register (WRSR) sequence	20
Figure 9.	Read from Memory Array (READ) sequence	21
Figure 10.	Byte Write (WRITE) sequence	22
Figure 11.	Page Write (WRITE) sequence	23
Figure 12.	Bus master and memory devices on the SPI bus.	24
Figure 13.	SPI modes supported	25
Figure 14.	AC measurement I/O waveform	27
Figure 15.	Serial input timing	34
Figure 16.	Hold timing	34
Figure 17.	Output timing	35
Figure 18.	SO8 narrow – 8 lead plastic small outline, 150 mils body width, package outline	36
Figure 19.	SO8 wide – 8 lead plastic small outline, 200 mils body width, package outline	37
Figure 20.	TSSOP8 – 8 lead thin shrink small outline, package outline	38

1 Description

The M95256, M95256-W and M95256-R are electrically erasable programmable memory (EEPROM) devices. They are accessed by a high speed SPI-compatible bus. Their memory array is organized as 32768 x 8 bits.

The device is accessed by a simple serial interface that is SPI-compatible. The bus signals are C, D and Q, as shown in [Table 1](#) and [Figure 1](#).

The device is selected when Chip Select (\bar{S}) is taken low. Communications with the device can be interrupted using Hold (\overline{HOLD}).

In order to meet environmental requirements, ST offers these devices in ECOPACK® packages. ECOPACK® packages are Lead-free and RoHS compliant.

ECOPACK is an ST trademark. ECOPACK specifications are available at: www.st.com.

Figure 1. Logic diagram

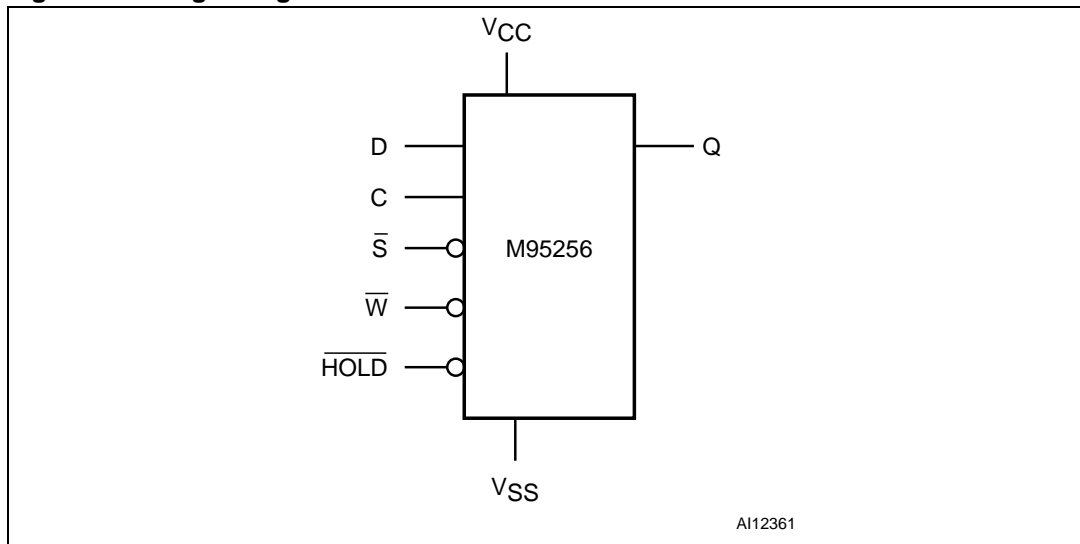
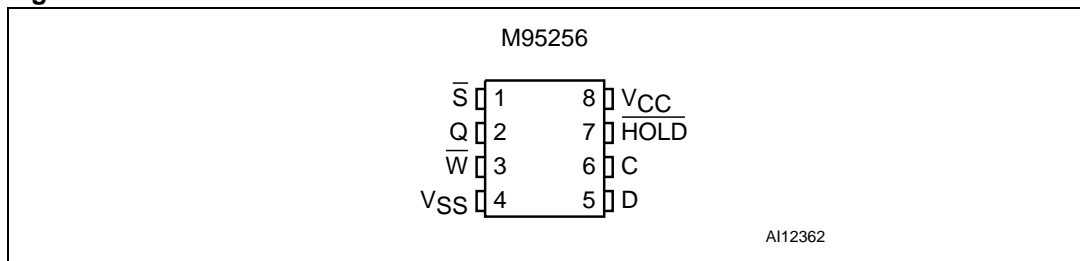

Figure 2. SO and TSSOP connections



1. See [Section 10: Package mechanical](#) for package dimensions, and how to identify pin-1.

Table 1. Signal names

Signal name	Function	Direction
C	Serial Clock	Input
D	Serial Data Input	Input
Q	Serial Data Output	Output
\overline{S}	Chip Select	Input
\overline{W}	Write Protect	Input
\overline{HOLD}	Hold	Input
V _{CC}	Supply voltage	
V _{SS}	Ground	

2 Memory organization

The memory is organized as shown in [Figure 3](#).

Figure 3. Block diagram

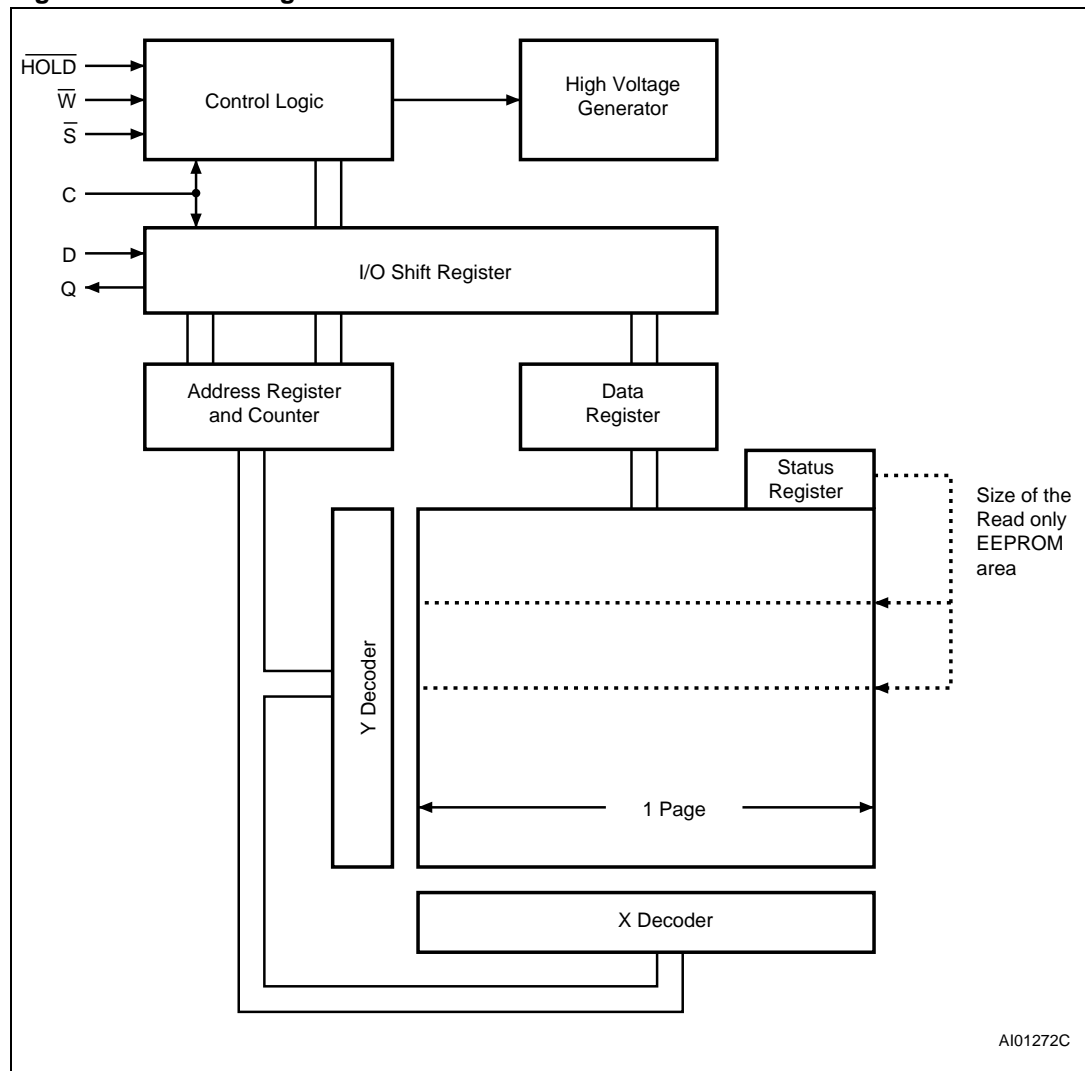

3 Signal description

See [Figure 1: Logic diagram](#) and [Table 1: Signal names](#), for a brief overview of the signals connected to this device.

3.1 Serial Data output (Q)

This output signal is used to transfer data serially out of the device. Data is shifted out on the falling edge of Serial Clock (C).

3.2 Serial Data input (D)

This input signal is used to transfer data serially into the device. It receives instructions, addresses, and the data to be written. Values are latched on the rising edge of Serial Clock (C).

3.3 Serial Clock (C)

This input signal provides the timing of the serial interface. Instructions, addresses, or data present at Serial Data Input (D) are latched on the rising edge of Serial Clock (C). Data on Serial Data Output (Q) changes after the falling edge of Serial Clock (C).

3.4 Chip Select (\overline{S})

When this input signal is high, the device is deselected and Serial Data Output (Q) is at high impedance. Unless an internal Write cycle is in progress, the device will be in the Standby Power mode. Driving Chip Select (\overline{S}) low selects the device, placing it in the Active Power mode.

After Power-up, a falling edge on Chip Select (\overline{S}) is required prior to the start of any instruction.

3.5 Hold (\overline{HOLD})

The Hold (\overline{HOLD}) signal is used to pause any serial communications with the device without deselecting the device.

During the Hold condition, the Serial Data Output (Q) is high impedance, and Serial Data Input (D) and Serial Clock (C) are Don't Care.

To start the Hold condition, the device must be selected, with Chip Select (\overline{S}) driven low.

3.6 Write Protect (\overline{W})

The main purpose of this input signal is to freeze the size of the area of memory that is protected against Write instructions (as specified by the values in the BP1 and BP0 bits of the Status Register).

This pin must be driven either high or low, and must be stable during all write instructions.

3.7 V_{SS} ground

V_{SS} is the reference for the V_{CC} supply voltage.

3.8 Supply voltage (V_{CC})

3.8.1 Operating supply voltage V_{CC}

Prior to selecting the memory and issuing instructions to it, a valid and stable V_{CC} voltage within the specified [$V_{CC}(\min)$, $V_{CC}(\max)$] range must be applied (see [Table 7](#), [Table 8](#) and [Table 9](#)). In order to secure a stable DC supply voltage, it is recommended to decouple the V_{CC} line with a suitable capacitor (usually of the order of 10 nF to 100 nF) close to the V_{CC}/V_{SS} package pins.

This voltage must remain stable and valid until the end of the transmission of the instruction and, for a Write instruction, until the completion of the internal write cycle (t_W).

3.8.2 Power-up conditions

When the power supply is turned on, V_{CC} continuously rises from V_{SS} to V_{CC} . During this time, the Chip Select (\overline{S}) line is not allowed to float but should follow the V_{CC} voltage, it is therefore recommended to connect the \overline{S} line to V_{CC} via a suitable pull-up resistor.

In addition, the Chip Select (\overline{S}) input offers a built-in safety feature, as the \overline{S} input is edge-sensitive as well as level-sensitive: after power-up, the device does not become selected until a falling edge has first been detected on Chip Select (\overline{S}). This ensures that Chip Select (\overline{S}) must have been high, prior to going low to start the first operation.

The V_{CC} rise time must not vary faster than 1 V/ μ s.

3.8.3 Device Reset

In order to prevent inadvertent write operations during power-up (continuous rise in V_{CC}), a power on reset (POR) circuit is included. At power-up, the device does not respond to any instruction until V_{CC} has reached the power on reset threshold voltage (this threshold is lower than the minimum V_{CC} operating voltage defined in [Table 7](#), [Table 8](#) and [Table 9](#)).

When V_{CC} passes over the POR threshold, the device is reset and is in the following state:

- Standby Power mode
- deselected (at next power-up, a falling edge is required on Chip Select (\overline{S}) before any instruction can be started).
- not in the Hold condition
- Status register:
 - the Write Enable Latch (WEL) is reset to 0
 - the Write In Progress (WIP) is reset to 0
 - the SRWD, BP1 and BP0 bits of the Status Register are unchanged from the previous power-down (they are non-volatile bits)

3.8.4 Power-down

At power-down (continuous decrease in V_{CC}), as soon as V_{CC} drops from the normal operating voltage to below the power on reset threshold voltage, the device stops responding to any instruction sent to it. During power-down, the device must be deselected (the Chip Select (\overline{S}) should be allowed to follow the voltage applied on V_{CC}) and in Standby Power mode (that is, there should be no internal Write cycle in progress).

4 Operating features

4.1 Hold condition

The Hold (\overline{HOLD}) signal is used to pause any serial communications with the device without resetting the clocking sequence.

During the Hold condition, the Serial Data Output (Q) is high impedance, and Serial Data Input (D) and Serial Clock (C) are Don't Care.

To enter the Hold condition, the device must be selected, with Chip Select (\overline{S}) low.

Normally, the device is kept selected, for the whole duration of the Hold condition. Deselecting the device while it is in the Hold condition, has the effect of resetting the state of the device, and this mechanism can be used if it is required to reset any processes that had been in progress.

The Hold condition starts when the Hold (\overline{HOLD}) signal is driven low at the same time as Serial Clock (C) already being low (as shown in [Figure 4](#)).

The Hold condition ends when the Hold (\overline{HOLD}) signal is driven high at the same time as Serial Clock (C) already being low.

[Figure 4](#) also shows what happens if the rising and falling edges are not timed to coincide with Serial Clock (C) being low.

Figure 4. Hold condition activation

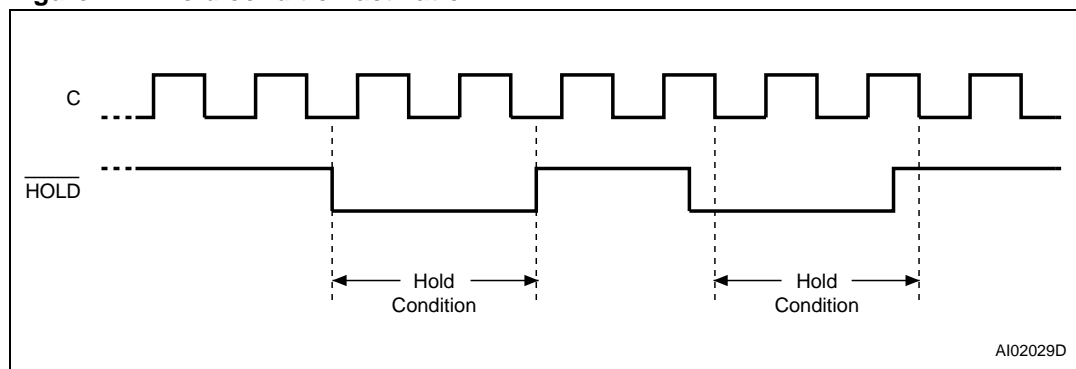

4.2 Status Register

[Figure 3](#) shows the position of the Status Register in the control logic of the device. The Status Register contains a number of status and control bits that can be read or set (as appropriate) by specific instructions. For a detailed description of the Status Register bits, see [Section 5.3: Read Status Register \(RDSR\)](#).

4.3 Data protection and protocol control

Non-volatile memory devices can be used in environments that are particularly noisy, and within applications that could experience problems if memory bytes are corrupted. Consequently, the device features the following data protection mechanisms:

- Write and Write Status Register instructions are checked that they consist of a number of clock pulses that is a multiple of eight, before they are accepted for execution.
- All instructions that modify data must be preceded by a Write Enable (WREN) instruction to set the Write Enable Latch (WEL) bit. This bit is returned to its reset state by the following events:
 - Power-up
 - Write Disable (WRDI) instruction completion
 - Write Status Register (WRSR) instruction completion
 - Write (WRITE) instruction completion
- The Block Protect (BP1, BP0) bits in the Status Register allow part of the memory to be configured as read-only.
- The Write Protect (\overline{WP}) signal allows the Block Protect (BP1, BP0) bits of the Status Register to be protected.

For any instruction to be accepted, and executed, Chip Select (\overline{CS}) must be driven high after the rising edge of Serial Clock (C) for the last bit of the instruction, and before the next rising edge of Serial Clock (C).

Two points need to be noted in the previous sentence:

- The 'last bit of the instruction' can be the eighth bit of the instruction code, or the eighth bit of a data byte, depending on the instruction (except for Read Status Register (RDSR) and Read (READ) instructions).
- The 'next rising edge of Serial Clock (C)' might (or might not) be the next bus transaction for some other device on the SPI bus.

Table 2. Write-protected block size

Status Register bits		Protected block	Array addresses protected
BP1	BP0		M95256, M95256-W, M95256-R
0	0	none	none
0	1	Upper quarter	6000h - 7FFFh
1	0	Upper half	4000h - 7FFFh
1	1	Whole memory	0000h - 7FFFh

5 Instructions

Each instruction starts with a single-byte code, as summarized in [Table 3](#).

If an invalid instruction is sent (one not contained in [Table 3](#)), the device automatically deselects itself.

Table 3. Instruction set

Instruction	Description	Instruction format
WREN	Write Enable	0000 0110
WRDI	Write Disable	0000 0100
RDSR	Read Status Register	0000 0101
WRSR	Write Status Register	0000 0001
READ	Read from Memory Array	0000 0011
WRITE	Write to Memory Array	0000 0010

5.1 Write Enable (WREN)

The Write Enable Latch (WEL) bit must be set prior to each WRITE and WRSR instruction. The only way to do this is to send a Write Enable instruction to the device.

As shown in [Figure 5](#), to send this instruction to the device, Chip Select (\bar{S}) is driven low, and the bits of the instruction byte are shifted in, on Serial Data Input (D). The device then enters a wait state. It waits for the device to be deselected, by Chip Select (\bar{S}) being driven high.

Figure 5. Write Enable (WREN) sequence

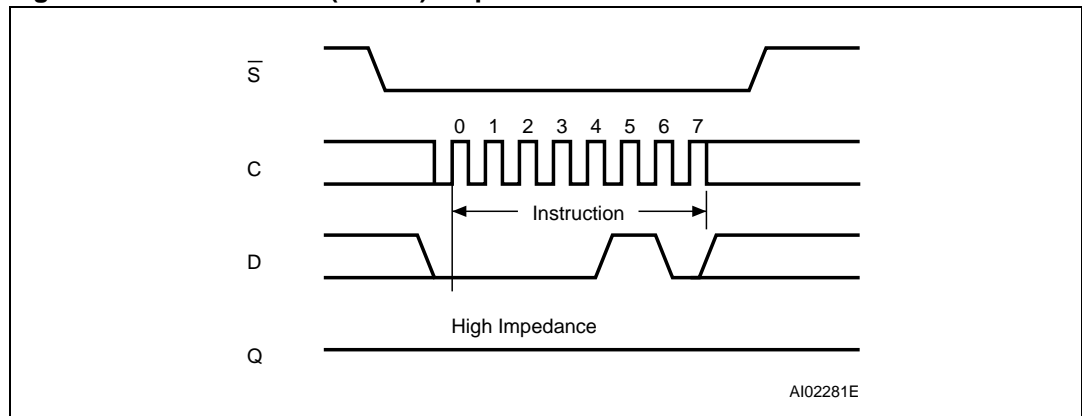

5.2 Write Disable (WRDI)

One way of resetting the Write Enable Latch (WEL) bit is to send a Write Disable instruction to the device.

As shown in [Figure 6](#), to send this instruction to the device, Chip Select (\bar{S}) is driven low, and the bits of the instruction byte are shifted in, on Serial Data Input (D).

The device then enters a wait state. It waits for a the device to be deselected, by Chip Select (\bar{S}) being driven high.

The Write Enable Latch (WEL) bit, in fact, becomes reset by any of the following events:

- Power-up
- WRDI instruction execution
- WRSR instruction completion
- WRITE instruction completion.

Figure 6. Write Disable (WRDI) sequence

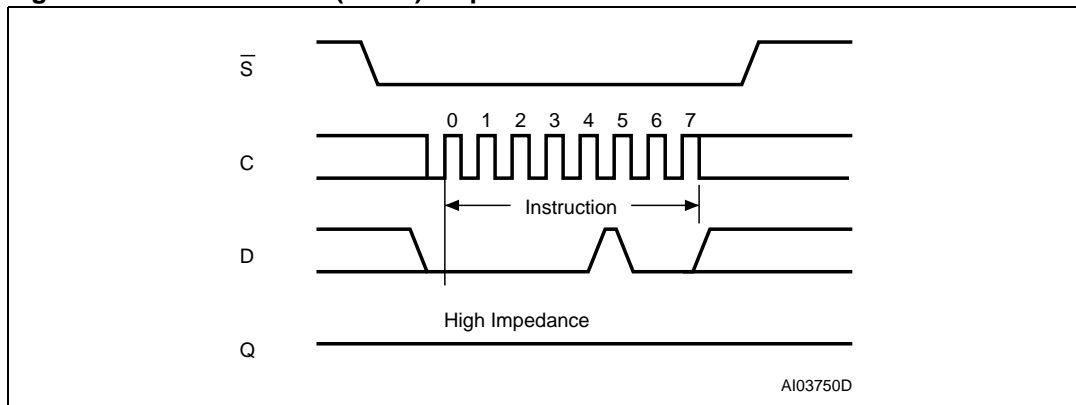

5.3 Read Status Register (RDSR)

The Read Status Register (RDSR) instruction allows the Status Register to be read. The Status Register may be read at any time, even while a Write or Write Status Register cycle is in progress. When one of these cycles is in progress, it is recommended to check the Write In Progress (WIP) bit before sending a new instruction to the device. It is also possible to read the Status Register continuously, as shown in [Figure 7](#).

The status and control bits of the Status Register are as follows:

5.3.1 WIP bit

The Write In Progress (WIP) bit indicates whether the memory is busy with a Write or Write Status Register cycle. When set to 1, such a cycle is in progress, when reset to 0 no such cycle is in progress.

5.3.2 WEL bit

The Write Enable Latch (WEL) bit indicates the status of the internal Write Enable Latch. When set to 1 the internal Write Enable Latch is set, when set to 0 the internal Write Enable Latch is reset and no Write or Write Status Register instruction is accepted.

5.3.3 BP1, BP0 bits

The Block Protect (BP1, BP0) bits are non-volatile. They define the size of the area to be software protected against Write instructions. These bits are written with the Write Status Register (WRSR) instruction. When one or both of the Block Protect (BP1, BP0) bits is set to 1, the relevant memory area (as defined in [Table 4](#)) becomes protected against Write (WRITE) instructions. The Block Protect (BP1, BP0) bits can be written provided that the Hardware Protected mode has not been set.

5.3.4 SRWD bit

The Status Register Write Disable (SRWD) bit is operated in conjunction with the Write Protect (\bar{W}) signal. The Status Register Write Disable (SRWD) bit and Write Protect (\bar{W}) signal allow the device to be put in the Hardware Protected mode (when the Status Register Write Disable (SRWD) bit is set to 1, and Write Protect (\bar{W}) is driven low). In this mode, the non-volatile bits of the Status Register (SRWD, BP1, BP0) become read-only bits and the Write Status Register (WRSR) instruction is no longer accepted for execution.

Table 4. Status Register format

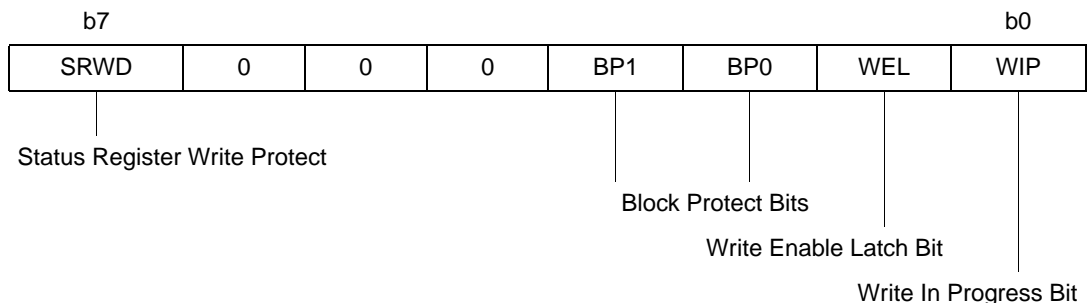
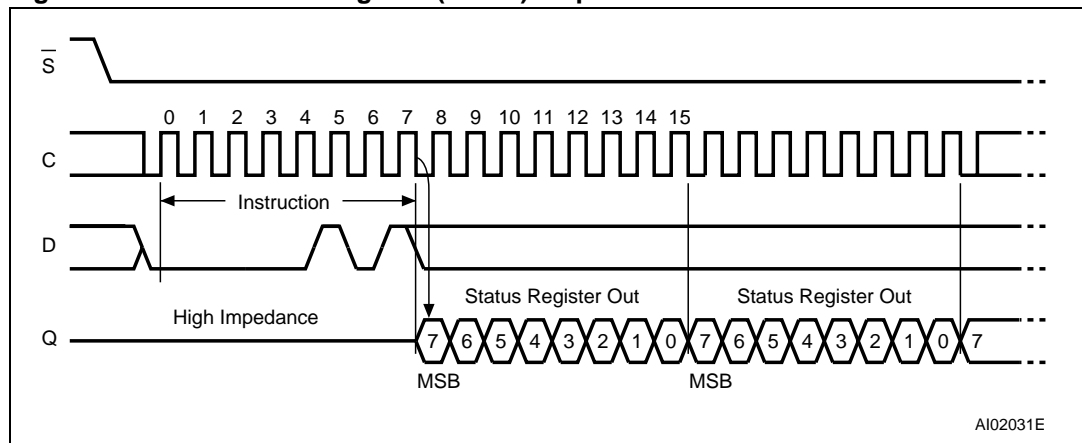

Figure 7. Read Status Register (RDSR) sequence



5.4 Write Status Register (WRSR)

The Write Status Register (WRSR) instruction allows new values to be written to the Status Register. Before it can be accepted, a Write Enable (WREN) instruction must have been previously executed. After the Write Enable (WREN) instruction has been decoded and executed, the Status Register is updated with the Write Enable Latch bit (WEL) set to 1.

The Write Status Register (WRSR) instruction is entered by driving Chip Select (\overline{S}) low, followed by the instruction code and the data byte on Serial Data Input (D). The instruction is terminated by driving Chip Select (\overline{S}) high at a byte boundary of the input data. This event triggers the self-timed write cycle, and continues for a period t_W (as specified in [Table 16](#), [Table 17](#), [Table 18](#) and [Table 19](#)), at the end of which the Write in Progress (WIP) bit is reset to 0.

The Write Status Register (WRSR) instruction has no effect on b6, b5, b4, b1 and b0 of the Status Register. b6, b5 and b4 are always read as 0.

Chip Select (\overline{S}) must be driven high after the rising edge of Serial Clock (C) that latches in the eighth bit of the data byte, and before the next rising edge of Serial Clock (C). Otherwise, the Write Status Register (WRSR) instruction is not executed.

While the Write Status Register cycle is in progress, the Status Register may still be read to check the value of the Write In Progress (WIP) bit. The Write In Progress (WIP) bit is 1 during the self-timed Write Status Register cycle t_W , and is 0 when it is completed. When the cycle is completed, the Write Enable Latch (WEL) is reset.

The Write Status Register (WRSR) instruction allows the user to change the values of the Block Protect (BP1, BP0) bits, to define the size of the area that is to be treated as read-only, as defined in [Table 4](#).

The Write Status Register (WRSR) instruction also allows the user to set or reset the Status Register Write Disable (SRWD) bit in accordance with the Write Protect (\overline{W}) signal. The Status Register Write Disable (SRWD) bit and Write Protect (\overline{W}) signal can be used to put the device in the Hardware-protected mode (HPM, see [Table 5](#)). In this mode, the Write Status Register (WRSR) instruction is not executed.

The contents of the SRWD and BP1, BP0 bits are updated after the completion of the Write Status Register (WRSR) instruction, including the t_W Write cycle.

The instruction sequence is shown in [Figure 8](#).

Table 5. Protection modes

\overline{W} signal	SRWD bit	Mode	Write protection of the Status Register	Memory content	
				Protected area ⁽¹⁾	Unprotected area ⁽¹⁾
1	0	Software Protected (SPM)	Status Register is Writable (if the WREN instruction has set the WEL bit) The values in the BP1 and BP0 bits can be changed	Write-protected	Ready to accept Write instructions
0	0				
1	1				
0	1	Hardware Protected (HPM)	Status Register is Hardware write protected The values in the BP1 and BP0 bits cannot be changed	Write-protected	Ready to accept Write instructions

1. As defined by the values in the Block Protect (BP1, BP0) bits of the Status Register, as shown in [Table 5](#).

The protection features of the device are summarized in [Table 2](#).

When the Status Register Write Disable (SRWD) bit of the Status Register is 0 (its initial delivery state), it is possible to write to the Status Register provided that the Write Enable Latch (WEL) bit has previously been set by a Write Enable (WREN) instruction, regardless of the whether Write Protect (\overline{W}) is driven high or low.

When the Status Register Write Disable (SRWD) bit of the Status Register is set to 1, two cases need to be considered, depending on the state of Write Protect (\overline{W}):

- If Write Protect (\overline{W}) is driven high, it is possible to write to the Status Register provided that the Write Enable Latch (WEL) bit has previously been set by a Write Enable (WREN) instruction.
- If Write Protect (\overline{W}) is driven low, it is *not* possible to write to the Status Register *even* if the Write Enable Latch (WEL) bit has previously been set by a Write Enable (WREN) instruction. (Attempts to write to the Status Register are rejected, and are not accepted for execution). As a consequence, all the data bytes in the memory area that are software protected (SPM) by the Block Protect (BP1, BP0) bits of the Status Register, are also hardware protected against data modification.

Regardless of the order of the two events, the Hardware Protected Mode (HPM) can be entered:

- by setting the Status Register Write Disable (SRWD) bit after driving Write Protect (\overline{W}) low
- or by driving Write Protect (\overline{W}) low after setting the Status Register Write Disable (SRWD) bit.

The only way to exit the Hardware Protected Mode (HPM) once entered is to pull Write Protect (\overline{W}) high.

If Write Protect (\overline{W}) is permanently tied high, the Hardware Protected Mode (HPM) can never be activated, and only the Software Protected Mode (SPM), using the Block Protect (BP1, BP0) bits of the Status Register, can be used.

Figure 8. Write Status Register (WRSR) sequence

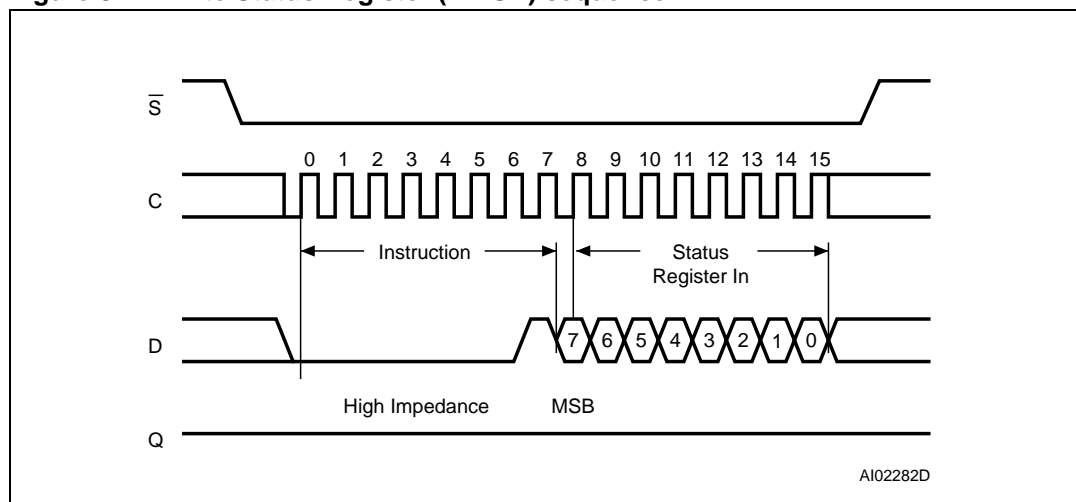

5.5 Read from Memory Array (READ)

As shown in *Figure 9*, to send this instruction to the device, Chip Select (\bar{S}) is first driven low. The bits of the instruction byte and address bytes are then shifted in, on Serial Data Input (D). The address is loaded into an internal address register, and the byte of data at that address is shifted out, on Serial Data Output (Q).

If Chip Select (\bar{S}) continues to be driven low, the internal address register is automatically incremented, and the byte of data at the new address is shifted out.

When the highest address is reached, the address counter rolls over to zero, allowing the Read cycle to be continued indefinitely. The whole memory can, therefore, be read with a single READ instruction.

The Read cycle is terminated by driving Chip Select (\bar{S}) high. The rising edge of the Chip Select (\bar{S}) signal can occur at any time during the cycle.

The first byte addressed can be any byte within any page.

The instruction is not accepted, and is not executed, if a Write cycle is currently in progress.

Figure 9. Read from Memory Array (READ) sequence

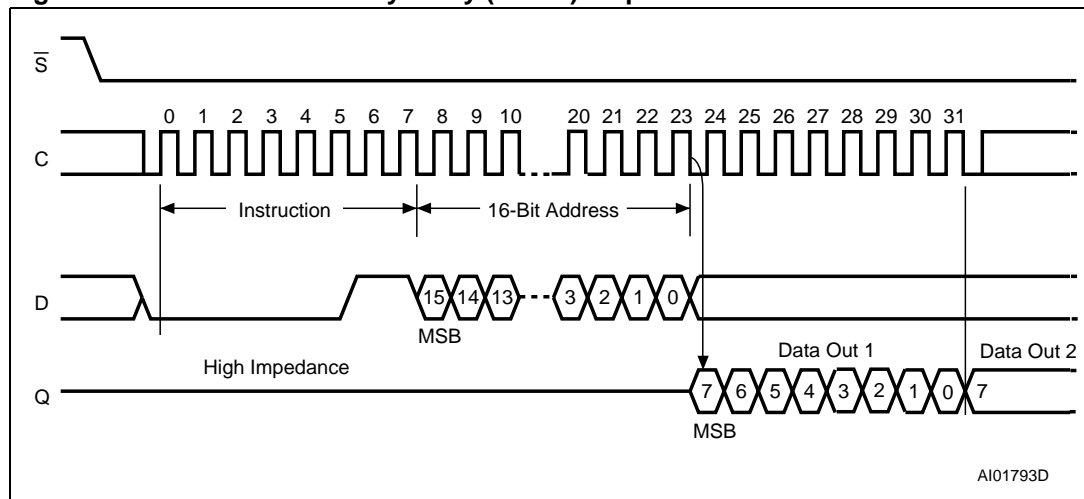

1. The most significant address bit (b15) is Don't Care.

5.6 Write to Memory Array (WRITE)

As shown in *Figure 10*, to send this instruction to the device, Chip Select (\overline{S}) is first driven low. The bits of the instruction byte, address bytes, and at least one data byte are then shifted in, on Serial Data Input (D). The instruction is terminated by driving Chip Select (\overline{S}) high at a byte boundary of the input data. The self-timed Write cycle, triggered by the rising edge of Chip Select (\overline{S}), continues for a period t_{WC} (as specified in *Table 16*, *Table 17*, *Table 18* and *Table 19*.), at the end of which the Write in Progress (WIP) bit is reset to 0.

In the case of *Figure 10*, Chip Select (\overline{S}) is driven high after the eighth bit of the data byte has been latched in, indicating that the instruction is being used to write a single byte. If, though, Chip Select (\overline{S}) continues to be driven low, as shown in *Figure 11*, the next byte of input data is shifted in, so that more than a single byte, starting from the given address towards the end of the same page, can be written in a single internal Write cycle.

Each time a new data byte is shifted in, the least significant bits of the internal address counter are incremented. If the number of data bytes sent to the device exceeds the page boundary, the internal address counter rolls over to the beginning of the page, and the previous data there are overwritten with the incoming data. (The page size of these devices is 64 bytes).

The instruction is not accepted, and is not executed, under the following conditions:

- if the Write Enable Latch (WEL) bit has not been set to 1 (by executing a Write Enable instruction just before)
- if a Write cycle is already in progress
- if the device has not been deselected, by Chip Select (\overline{S}) being driven high, at a byte boundary (after the eighth bit, b0, of the last data byte that has been latched in)
- if the addressed page is in the region protected by the Block Protect (BP1 and BP0) bits.

Figure 10. Byte Write (WRITE) sequence

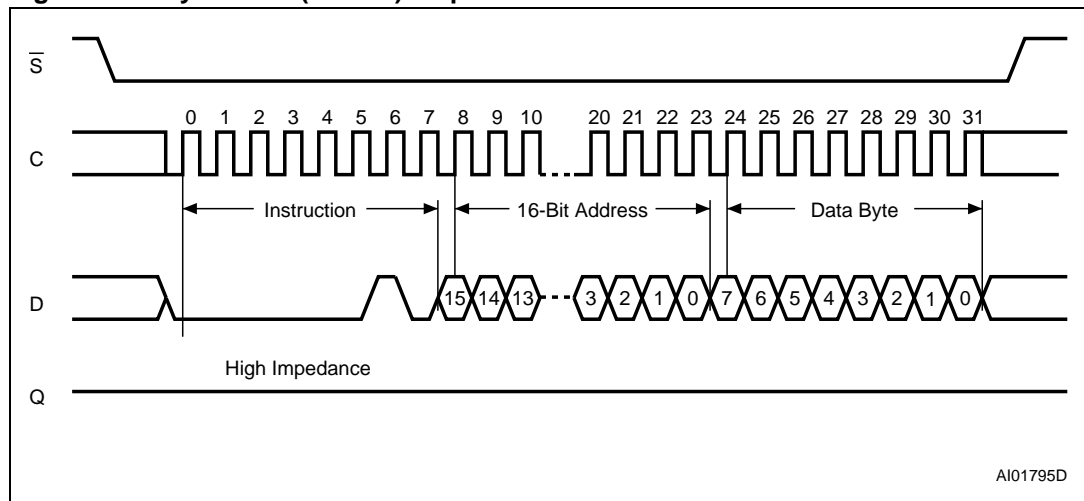

1. The most significant address bit (b15) is Don't Care.

Figure 11. Page Write (WRITE) sequence

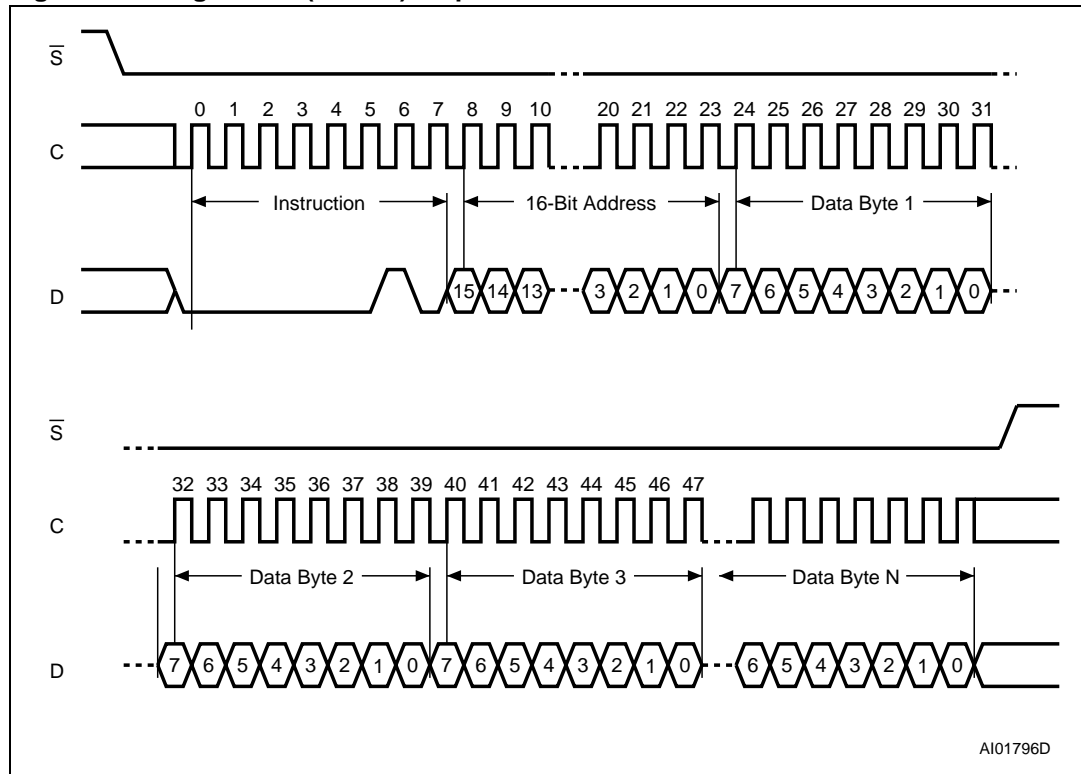

1. The most significant address bit (b15) is Don't Care.

5.6.1 ECC (error correction code) and Write cycling

The M95256, M95256-W and M95256-R devices offer an ECC (error correction code) logic which compares each 4-byte word with its associated 6 EEPROM bits of ECC. As a result, if a single bit out of 4 bytes of data happens to be erroneous during a Read operation, the ECC detects it and replaces it by the correct value. The read reliability is therefore much improved by the use of this feature.

Note however that even if a single byte has to be written, 4 bytes are internally modified (plus the ECC bits), that is, the addressed byte is cycled together with the three other bytes making up the word. It is therefore recommended to write by word (4 bytes) in order to benefit from the larger amount of Write cycles.

The M95256-W6 and M95256-R6 devices are qualified at 1 million (1 000 000) Write cycles, using a cycling routine that writes to the device by multiples of 4-byte words.

6 Delivery state

The device is delivered with the memory array set at all 1s (FFh). The Status Register Write Disable (SRWD) and Block Protect (BP1 and BP0) bits are initialized to 0.

7 Connecting to the SPI bus

These devices are fully compatible with the SPI protocol.

All instructions, addresses and input data bytes are shifted in to the device, most significant bit first. The Serial Data Input (D) is sampled on the first rising edge of the Serial Clock (C) after Chip Select (\bar{S}) goes low.

All output data bytes are shifted out of the device, most significant bit first. The Serial Data Output (Q) is latched on the first falling edge of the Serial Clock (C) after the instruction (such as the Read from Memory Array and Read Status Register instructions) have been clocked into the device.

Figure 12 shows an example of three memory devices connected to an MCU, on an SPI bus. Only one memory device is selected at a time, so only one memory device drives the Serial Data Output (Q) line at a time, the other memory devices are high impedance.

Figure 12. Bus master and memory devices on the SPI bus

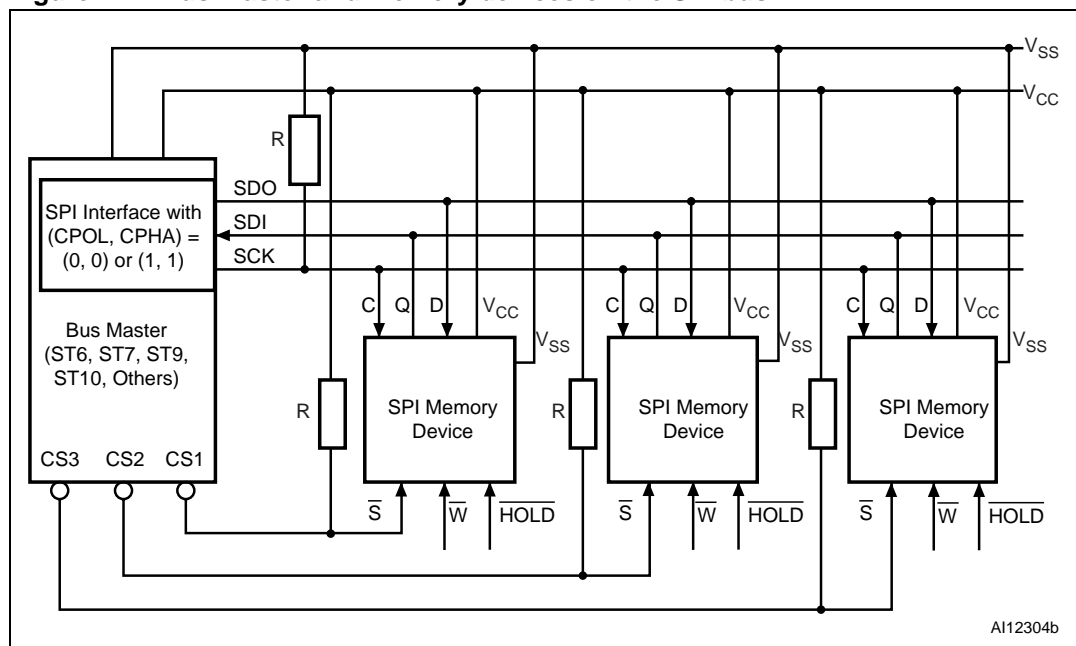

1. The Write Protect (\bar{W}) and Hold (\overline{HOLD}) signals should be driven, high or low as appropriate.

The pull-up resistor R (represented in Figure 12) ensures that a device is not selected if the bus master leaves the \bar{S} line in the high-impedance state.

In applications where the bus master might enter a state where all SPI bus inputs/outputs would be in high impedance at the same time (for example, if the bus master is reset during

the transmission of an instruction), the clock line (C) must be connected to an external pull-down resistor so that, if all inputs/outputs become high impedance, the C line is pulled low (while the \bar{S} line is pulled high): this ensures that \bar{S} and C do not become high at the same time, and so, that the t_{SHCH} requirement is met. The typical value of R is 100 k Ω .

7.1 SPI modes

These devices can be driven by a microcontroller with its SPI peripheral running in either of the two following modes:

- CPOL=0, CPHA=0
- CPOL=1, CPHA=1

For these two modes, input data is latched in on the rising edge of Serial Clock (C), and output data is available from the falling edge of Serial Clock (C).

The difference between the two modes, as shown in [Figure 13](#), is the clock polarity when the bus master is in Stand-by mode and not transferring data:

- C remains at 0 for (CPOL=0, CPHA=0)
- C remains at 1 for (CPOL=1, CPHA=1)

Figure 13. SPI modes supported

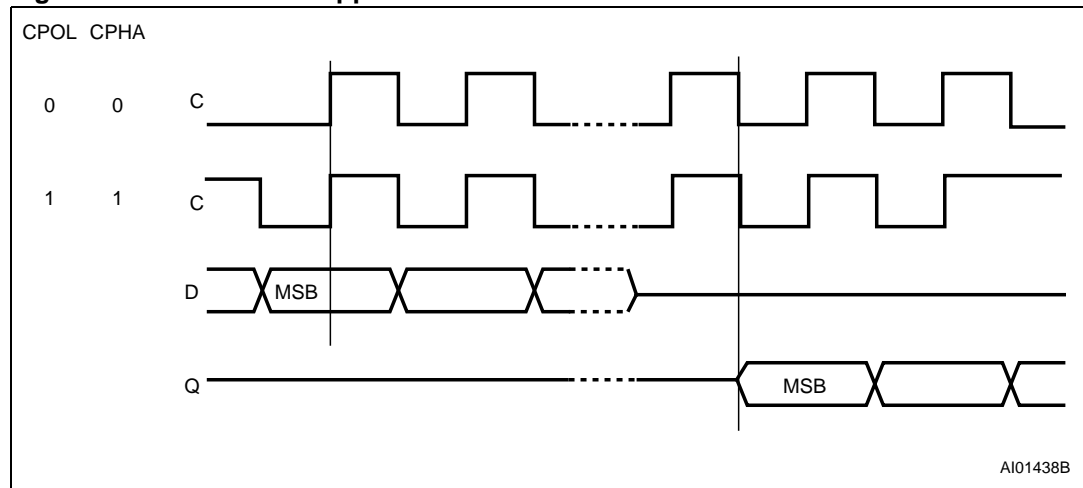

8 Maximum rating

Stressing the device outside the ratings listed in [Table 6](#) may cause permanent damage to the device. These are stress ratings only, and operation of the device at these, or any other conditions outside those indicated in the operating sections of this specification, is not implied. Exposure to absolute maximum rating conditions for extended periods may affect device reliability. Refer also to the STMicroelectronics SURE Program and other relevant quality documents.

Table 6. Absolute maximum ratings

Symbol	Parameter	Min.	Max.	Unit
T_A	Ambient operating temperature	-40	130	°C
T_{STG}	Storage temperature	-65	150	°C
T_{LEAD}	Lead temperature during soldering	see note ⁽¹⁾		
V_O	Output voltage	-0.50	$V_{CC}+0.6$	V
V_I	Input voltage	-0.50	6.5	V
V_{CC}	Supply voltage	-0.50	6.5	V
V_{ESD}	Electrostatic discharge voltage (human body model) ⁽²⁾	-4000	4000	V

1. Compliant with JEDEC Std J-STD-020D (for small body, Sn-Pb or Pb assembly), the ST ECOPACK® 7191395 specification, and the European directive on Restrictions on Hazardous Substances (RoHS) 2002/95/EU.
2. AEC-Q100-002 (compliant with JEDEC Std JESD22-A114A, C1=100pF, R1=1500W, R2=500Ω).

9 DC and AC parameters

This section summarizes the operating and measurement conditions, and the DC and AC characteristics of the device. The parameters in the DC and AC characteristic tables that follow are derived from tests performed under the measurement conditions summarized in the relevant tables. Designers should check that the operating conditions in their circuit match the measurement conditions when relying on the quoted parameters.

Table 7. Operating conditions (M95256)⁽¹⁾

Symbol	Parameter	Min.	Max.	Unit
V _{CC}	Supply voltage	4.5	5.5	V
T _A	Ambient operating temperature (device grade 3)	-40	125	°C

1. The 5V M95256 part is offered in "V" process (F6DP26%) only.

Table 8. Operating conditions (M95256-W)

Symbol	Parameter	Min.	Max.	Unit
V _{CC}	Supply voltage	2.5	5.5	V
T _A	Ambient operating temperature (device grade 6)	-40	85	°C
	Ambient operating temperature (device grade 3) ⁽¹⁾	-40	125	°C

1. This product is under development. For more information, please contact your nearest ST sales office.

Table 9. Operating conditions (M95256-R)

Symbol	Parameter	Min. ⁽¹⁾	Max. ⁽¹⁾	Unit
V _{CC}	Supply voltage	1.8	5.5	V
T _A	Ambient operating temperature	-40	85	°C

1. This product is under development. For more information, please contact your nearest ST sales office.

Table 10. AC measurement conditions⁽¹⁾

Symbol	Parameter	Min.	Max.	Unit
C _L	Load capacitance	100		pF
	Input rise and fall times		50	ns
	Input pulse voltages	0.2V _{CC} to 0.8V _{CC}		V
	Input and output timing reference voltages	0.3V _{CC} to 0.7V _{CC}		V

1. Output Hi-Z is defined as the point where data out is no longer driven.

Figure 14. AC measurement I/O waveform

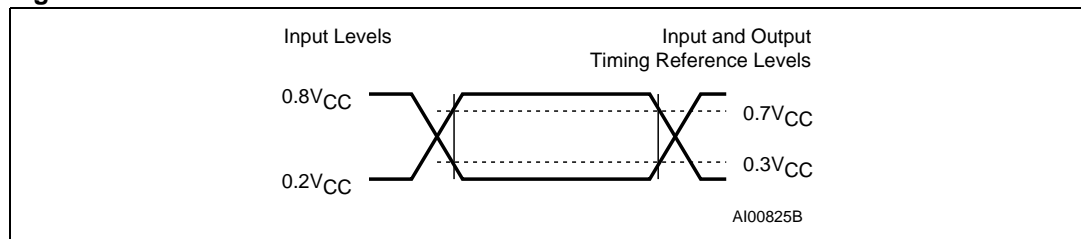

Table 11. Capacitance⁽¹⁾

Symbol	Parameter	Test condition	Min.	Max.	Unit
C _{OUT}	Output capacitance (Q)	V _{OUT} = 0 V		8	pF
C _{IN}	Input capacitance (D)	V _{IN} = 0 V		8	pF
	Input capacitance (other pins)	V _{IN} = 0 V		6	pF

1. Sampled only, not 100% tested, at T_A = 25 °C and a frequency of 5 MHz.

Table 12. DC characteristics (M95256, device grade 3)

Symbol	Parameter	Test condition	Min.	Max.	Unit
I _{LI}	Input leakage current	V _{IN} = V _{SS} or V _{CC}		± 2	µA
I _{LO}	Output leakage current	$\bar{S} = V_{CC}$, V _{OUT} = V _{SS} or V _{CC}		± 2	µA
I _{CC}	Supply current	C = 0.1V _{CC} /0.9V _{CC} at 5 MHz, V _{CC} = 5 V, Q = open		4	mA
I _{CC1}	Supply current (Standby Power mode)	$\bar{S} = V_{CC}$, V _{CC} = 5 V, V _{IN} = V _{SS} or V _{CC}		5	µA
V _{IL}	Input low voltage		-0.45	0.3 V _{CC}	V
V _{IH}	Input high voltage		0.7 V _{CC}	V _{CC} +1	V
V _{OL} ⁽¹⁾	Output low voltage	I _{OL} = 2 mA, V _{CC} = 5 V		0.4	V
V _{OH} ⁽¹⁾	Output high voltage	I _{OH} = -2 mA, V _{CC} = 5 V	0.8 V _{CC}		V

1. For all 5V range devices, the device meets the output requirements for both TTL and CMOS standards.

Table 13. DC characteristics (M95256-W, device grade 6)

Symbol	Parameter	Test condition	Min.	Max.	Unit
I _{LI}	Input leakage current	V _{IN} = V _{SS} or V _{CC}		± 2	µA
I _{LO}	Output leakage current	$\bar{S} = V_{CC}$, V _{OUT} = V _{SS} or V _{CC}		± 2	µA
I _{CC}	Supply current (Read)	C = 0.1V _{CC} /0.9V _{CC} at 5 MHz, V _{CC} = 2.5 V, Q = open		3	mA
		C = 0.1V _{CC} /0.9V _{CC} at 5 MHz, V _{CC} = 5V, Q = open		5	mA
I _{CC0} ⁽¹⁾	Supply current (Write)	During t _W , $\bar{S} = V_{CC}$, 2.5 V < V _{CC} < 5.5 V		5	mA
I _{CC1}	Supply current (Standby Power mode)	$\bar{S} = V_{CC}$, V _{IN} = V _{SS} or V _{CC} , 2.5 V < V _{CC} < 5.5 V		5	µA
V _{IL}	Input low voltage		-0.45	0.3 V _{CC}	V
V _{IH}	Input high voltage		0.7 V _{CC}	V _{CC} +1	V
V _{OL}	Output low voltage	V _{CC} = 2.5 V and I _{OL} = 1.5 mA or V _{CC} = 5 V and I _{OL} = 2 mA		0.4	V
V _{OH}	Output high voltage	V _{CC} = 2.5 V and I _{OH} = -0.4 mA or V _{CC} = 5 V and I _{OH} = -2 mA	0.8 V _{CC}		V

1. Characterized value, not tested in production.

Table 14. DC characteristics (M95256-W, device grade 3)

Symbol	Parameter	Test condition	Min.	Max.	Unit
I_{LI}	Input leakage current	$V_{IN} = V_{SS}$ or V_{CC}		± 2	μA
I_{LO}	Output leakage current	$\bar{S} = V_{CC}$, $V_{OUT} = V_{SS}$ or V_{CC}		± 2	μA
I_{CC}	Supply current (Read)	$C = 0.1V_{CC}/0.9V_{CC}$ at 5 MHz, $V_{CC} = 2.5 V$, Q = open		3	mA
$I_{CC0}^{(1)}$	Supply current (Write)	During t_W , $\bar{S} = V_{CC}$, $2.5 V < V_{CC} < 5.5 V$		6	mA
I_{CC1}	Supply current (Standby Power mode)	$\bar{S} = V_{CC}$, $V_{IN} = V_{SS}$ or V_{CC} $2.5 V < V_{CC} < 5.5 V$,		5	μA
V_{IL}	Input low voltage		-0.45	$0.3 V_{CC}$	V
V_{IH}	Input high voltage		$0.7 V_{CC}$	$V_{CC}+1$	V
V_{OL}	Output low voltage	$I_{OL} = 1.5 mA$, $V_{CC} = 2.5 V$		0.4	V
V_{OH}	Output high voltage	$I_{OH} = -0.4 mA$, $V_{CC} = 2.5 V$	$0.8 V_{CC}$		V

1. Characterized value, not tested in production.

Table 15. DC characteristics (M95256-R)

Symbol	Parameter	Test condition	Min	Max	Unit
I_{LI}	Input leakage current	$V_{IN} = V_{SS}$ or V_{CC}		± 2	μA
I_{LO}	Output leakage current	$\bar{S} = V_{CC}$, $V_{OUT} = V_{SS}$ or V_{CC}		± 2	μA
I_{CC}	Supply current (Read)	$C = 0.1V_{CC}/0.9V_{CC}$ at 2 MHz, $V_{CC} = 1.8 V$, Q = open		1 ⁽¹⁾	mA
$I_{CC0}^{(2)}$	Supply current (Write)	During t_W , $\bar{S} = V_{CC}$, $1.8 V < V_{CC} < 2.5 V$		3	mA
I_{CC1}	Supply current (Standby Power mode)	$\bar{S} = V_{CC}$, $V_{IN} = V_{SS}$ or V_{CC} , $1.8 V < V_{CC} < 2.5 V$		3 ⁽¹⁾	μA
V_{IL}	Input low voltage		-0.45	$0.25 V_{CC}$	V
V_{IH}	Input high voltage		$0.75 V_{CC}$	$V_{CC}+1$	V
V_{OL}	Output low voltage	$I_{OL} = 0.15 mA$, $V_{CC} = 1.8 V$		0.3	V
V_{OH}	Output high voltage	$I_{OH} = -0.1 mA$, $V_{CC} = 1.8 V$	$0.8 V_{CC}$		V

1. This is preliminary data.

2. Characterized value, not tested in production.

Table 16. AC characteristics (M95256, device grade 3)

Test conditions specified in Table 10 and Table 7					
Symbol	Alt.	Parameter	Min.	Max.	Unit
f_C	f_{SCK}	Clock frequency	D.C.	5	MHz
t_{SLCH}	t_{CSS1}	\overline{S} active setup time	90		ns
t_{SHCH}	t_{CSS2}	\overline{S} not active setup time	90		ns
t_{SHSL}	t_{CS}	\overline{S} deselect time	100		ns
t_{CHSH}	t_{CSH}	\overline{S} active hold time	90		ns
t_{CHSL}		\overline{S} not active hold time	90		ns
$t_{CH}^{(1)}$	t_{CLH}	Clock high time	90		ns
$t_{CL}^{(1)}$	t_{CLL}	Clock low time	90		ns
$t_{CLCH}^{(2)}$	t_{RC}	Clock rise time		1	μ s
$t_{CHCL}^{(2)}$	t_{FC}	Clock fall time		1	μ s
t_{DVCH}	t_{DSU}	Data in setup time	20		ns
t_{CHDX}	t_{DH}	Data in hold time	30		ns
t_{HHCH}		Clock low hold time after \overline{HOLD} not active	70		ns
t_{HLCH}		Clock low hold time after \overline{HOLD} active	40		ns
t_{CLHL}		Clock low setup time before \overline{HOLD} active	0		ns
t_{CLHH}		Clock low setup time before \overline{HOLD} not active	0		ns
$t_{SHQZ}^{(2)}$	t_{DIS}	Output disable time		100	ns
t_{CLQV}	t_V	Clock low to output valid		60	ns
t_{CLQX}	t_{HO}	Output hold time	0		ns
$t_{QLQH}^{(2)}$	t_{RO}	Output rise time		50	ns
$t_{QHQL}^{(2)}$	t_{FO}	Output fall time		50	ns
t_{HHQV}	t_{LZ}	\overline{HOLD} high to output valid		50	ns
$t_{HLQZ}^{(2)}$	t_{HZ}	\overline{HOLD} low to output High-Z		100	ns
t_W	t_{WC}	Write time		5	ms

- $t_{CH} + t_{CL}$ must never be less than the shortest possible clock period, $1 / f_C(\max)$
- Value guaranteed by characterization, not 100% tested in production.

Table 17. AC characteristics (M95256-W, device grade 6)

Test conditions specified in Table 10 and Table 8					
Symbol	Alt.	Parameter	Min.	Max.	Unit
f_C	f_{SCK}	Clock frequency	D.C.	5	MHz
t_{SLCH}	t_{CSS1}	\overline{S} active setup time	90		ns
t_{SHCH}	t_{CSS2}	\overline{S} not active setup time	90		ns
t_{SHSL}	t_{CS}	\overline{S} deselect time	100		ns
t_{CHSH}	t_{CSH}	\overline{S} active hold time	90		ns
t_{CHSL}		\overline{S} not active hold time	90		ns
$t_{CH}^{(1)}$	t_{CLH}	Clock high time	90		ns
$t_{CL}^{(1)}$	t_{CLL}	Clock low time	90		ns
$t_{CLCH}^{(2)}$	t_{RC}	Clock rise time		1	μ s
$t_{CHCL}^{(2)}$	t_{FC}	Clock fall time		1	μ s
t_{DVCH}	t_{DSU}	Data in setup time	20		ns
t_{CHDX}	t_{DH}	Data in hold time	30		ns
t_{HHCH}		Clock low hold time after \overline{HOLD} not active	70		ns
t_{HLCH}		Clock low hold time after \overline{HOLD} active	40		ns
t_{CLHL}		Clock low setup time before \overline{HOLD} active	0		ns
t_{CLHH}		Clock low setup time before \overline{HOLD} not active	0		ns
$t_{SHQZ}^{(2)}$	t_{DIS}	Output disable time		100	ns
t_{CLQV}	t_V	Clock low to output valid		60	ns
t_{CLQX}	t_{HO}	Output hold time	0		ns
$t_{QLQH}^{(2)}$	t_{RO}	Output rise time		50	ns
$t_{QHQL}^{(2)}$	t_{FO}	Output fall time		50	ns
t_{HHQV}	t_{LZ}	\overline{HOLD} high to output valid		50	ns
$t_{HLQZ}^{(2)}$	t_{HZ}	\overline{HOLD} low to output High-Z		100	ns
t_W	t_{WC}	Write time		5	ms

1. $t_{CH} + t_{CL}$ must never be less than the shortest possible clock period, $1 / f_C(\max)$

2. Value guaranteed by characterization, not 100% tested in production.

Table 18. AC characteristics (M95256-W, device grade 3)

Test conditions specified in Table 10 and Table 8					
Symbol	Alt.	Parameter	Min.	Max.	Unit
f_C	f_{SCK}	Clock frequency	D.C.	5	MHz
t_{SLCH}	t_{CSS1}	\overline{S} active setup time	90		ns
t_{SHCH}	t_{CSS2}	\overline{S} not active setup time	90		ns
t_{SHSL}	t_{CS}	\overline{S} deselect time	100		ns
t_{CHSH}	t_{CSH}	\overline{S} active hold time	90		ns
t_{CHSL}		\overline{S} not active hold time	90		ns
$t_{CH}^{(1)}$	t_{CLH}	Clock high time	90		ns
$t_{CL}^{(1)}$	t_{CLL}	Clock low time	90		ns
$t_{CLCH}^{(2)}$	t_{RC}	Clock rise time		1	μ s
$t_{CHCL}^{(2)}$	t_{FC}	Clock fall time		1	μ s
t_{DVCH}	t_{DSU}	Data in setup time	20		ns
t_{CHDX}	t_{DH}	Data in hold time	30		ns
t_{HHCH}		Clock low hold time after \overline{HOLD} not active	70		ns
t_{HLCH}		Clock low hold time after \overline{HOLD} active	40		ns
t_{CLHL}		Clock low setup time before \overline{HOLD} active	0		ns
t_{CLHH}		Clock low setup time before \overline{HOLD} not active	0		ns
$t_{SHQZ}^{(2)}$	t_{DIS}	Output disable time		100	ns
t_{CLQV}	t_V	Clock low to output valid		60	ns
t_{CLQX}	t_{HO}	Output hold time	0		ns
$t_{QLQH}^{(2)}$	t_{RO}	Output rise time		50	ns
$t_{QHQL}^{(2)}$	t_{FO}	Output fall time		50	ns
t_{HHQV}	t_{LZ}	\overline{HOLD} high to output valid		50	ns
$t_{HLQZ}^{(2)}$	t_{HZ}	\overline{HOLD} low to output High-Z		100	ns
t_W	t_{WC}	Write time		5	ms

1. $t_{CH} + t_{CL}$ must never be less than the shortest possible clock period, $1 / f_C(\max)$

2. Value guaranteed by characterization, not 100% tested in production.

Table 19. AC characteristics (M95256-R)

Test conditions specified in Table 10 and Table 9					
Symbol	Alt.	Parameter	Min.	Max.	Unit
f_C	f_{SCK}	Clock frequency	D.C.	2	MHz
t_{SLCH}	t_{CSS1}	\overline{S} active setup time	200		ns
t_{SHCH}	t_{CSS2}	\overline{S} not active setup time	200		ns
t_{SHSL}	t_{CS}	\overline{S} deselect time	200		ns
t_{CHSH}	t_{CSH}	\overline{S} active hold time	200		ns
t_{CHSL}		\overline{S} not active hold time	200		ns
$t_{CH}^{(1)}$	t_{CLH}	Clock high time	200		ns
$t_{CL}^{(1)}$	t_{CLL}	Clock low time	200		ns
$t_{CLCH}^{(2)}$	t_{RC}	Clock rise time		1	μ s
$t_{CHCL}^{(2)}$	t_{FC}	Clock fall time		1	μ s
t_{DVCH}	t_{DSU}	Data in setup time	40		ns
t_{CHDX}	t_{DH}	Data in hold time	50		ns
t_{HHCH}		Clock low hold time after \overline{HOLD} not active	140		ns
t_{HLCH}		Clock low hold time after \overline{HOLD} active	90		ns
t_{CLHL}		Clock low setup time before \overline{HOLD} active	0		ns
t_{CLHH}		Clock low setup time before \overline{HOLD} not active	0		ns
$t_{SHQZ}^{(2)}$	t_{DIS}	Output disable time		250	ns
t_{CLQV}	t_V	Clock low to output valid		150	ns
t_{CLQX}	t_{HO}	Output hold time	0		ns
$t_{QLQH}^{(2)}$	t_{RO}	Output rise time		100	ns
$t_{QHQL}^{(2)}$	t_{FO}	Output fall time		100	ns
t_{HHQV}	t_{LZ}	\overline{HOLD} high to output valid		100	ns
$t_{HLQZ}^{(2)}$	t_{HZ}	\overline{HOLD} low to output High-Z		250	ns
t_W	t_{WC}	Write time		5	ms

- $t_{CH} + t_{CL}$ must never be less than the shortest possible clock period, $1 / f_C(\max)$
- Value guaranteed by characterization, not 100% tested in production.

Figure 15. Serial input timing

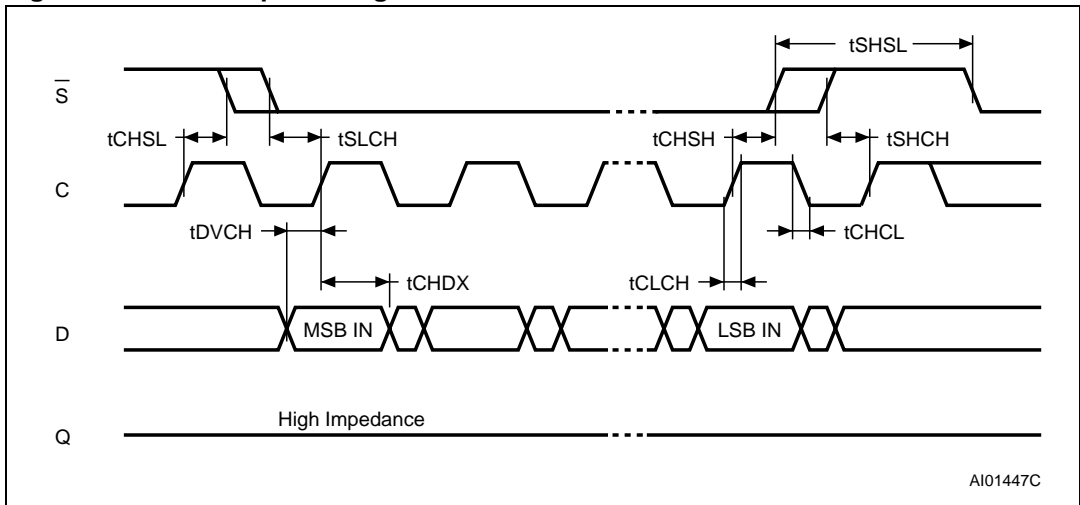

Figure 16. Hold timing

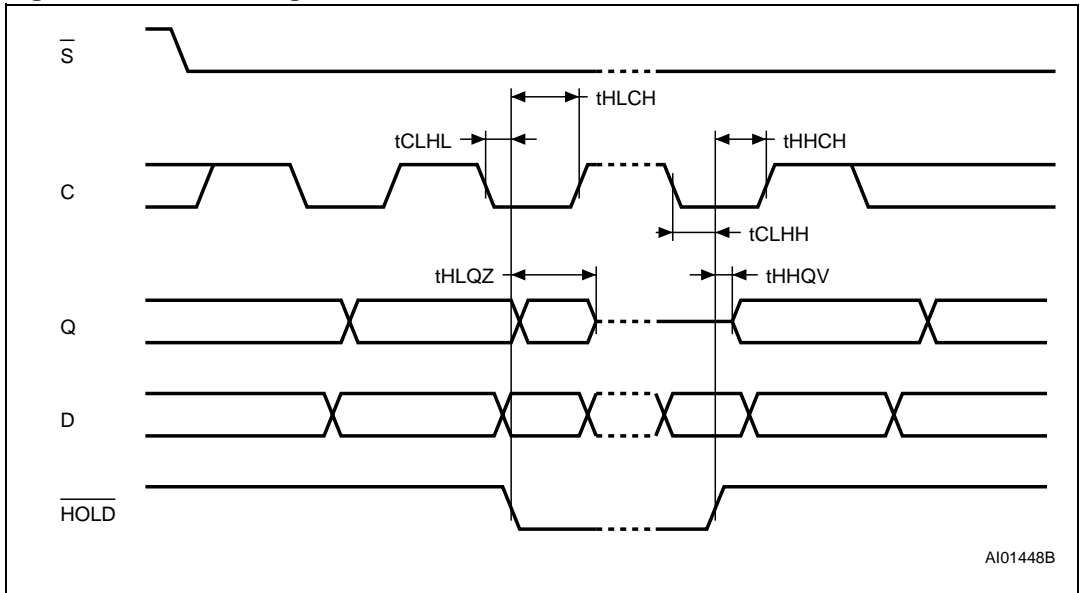
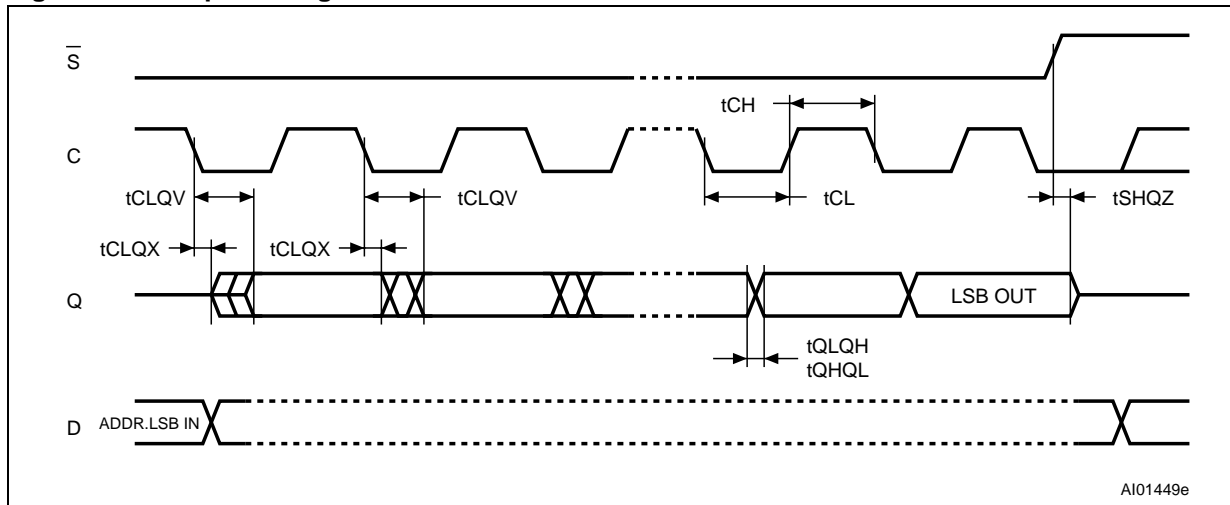
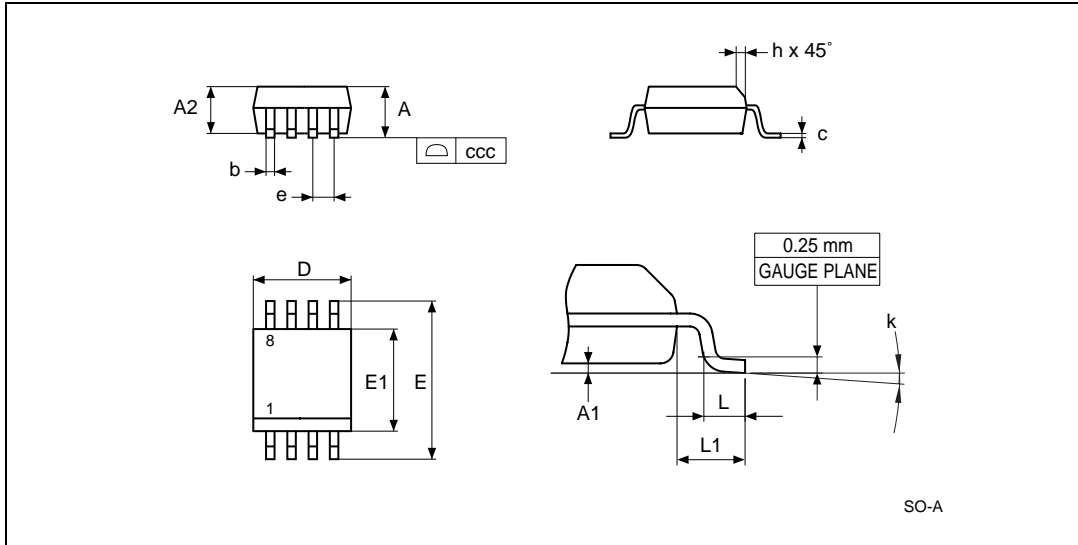

Figure 17. Output timing



10 Package mechanical

Figure 18. SO8 narrow – 8 lead plastic small outline, 150 mils body width, package outline



1. Drawing is not to scale.

Table 20. SO8 narrow – 8 lead plastic small outline, 150 mils body width, package mechanical data

Symbol	millimeters			inches ⁽¹⁾		
	Typ	Min	Max	Typ	Min	Max
A			1.75			0.0689
A1		0.1	0.25		0.0039	0.0098
A2		1.25			0.0492	
b		0.28	0.48		0.011	0.0189
c		0.17	0.23		0.0067	0.0091
ccc			0.1			0.0039
D	4.9	4.8	5	0.1929	0.189	0.1969
E	6	5.8	6.2	0.2362	0.2283	0.2441
E1	3.9	3.8	4	0.1535	0.1496	0.1575
e	1.27	-	-	0.05	-	-
h		0.25	0.5		0.0098	0.0197
k		0°	8°		0°	8°
L		0.4	1.27		0.0157	0.05
L1	1.04			0.0409		

1. Values in inches are converted from mm and rounded to 4 decimal digits.

Figure 19. SO8 wide – 8 lead plastic small outline, 200 mils body width, package outline

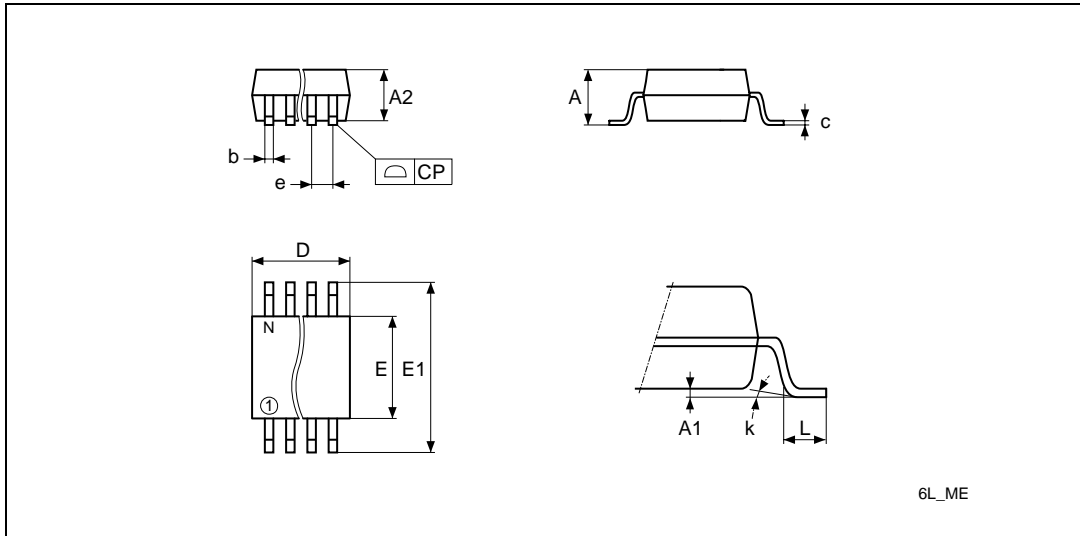

1. Drawing is not to scale.

Table 21. SO8 wide – 8 lead plastic small outline, 200 mils body width, package mechanical data

Symbol	millimeters			inches ⁽¹⁾		
	Typ	Min	Max	Typ	Min	Max
A			2.5			0.0984
A1		0	0.25		0	0.0098
A2		1.51	2		0.0594	0.0787
b	0.4	0.35	0.51	0.0157	0.0138	0.0201
c	0.2	0.1	0.35	0.0079	0.0039	0.0138
CP			0.1			0.0039
D			6.05			0.2382
E		5.02	6.22		0.1976	0.2449
E1		7.62	8.89		0.3	0.35
e	1.27	-	-	0.05	-	-
k		0°	10°		0°	10°
L		0.5	0.8		0.0197	0.0315
N	8			8		

1. Values in inches are converted from mm and rounded to 4 decimal digits.

Figure 20. TSSOP8 – 8 lead thin shrink small outline, package outline

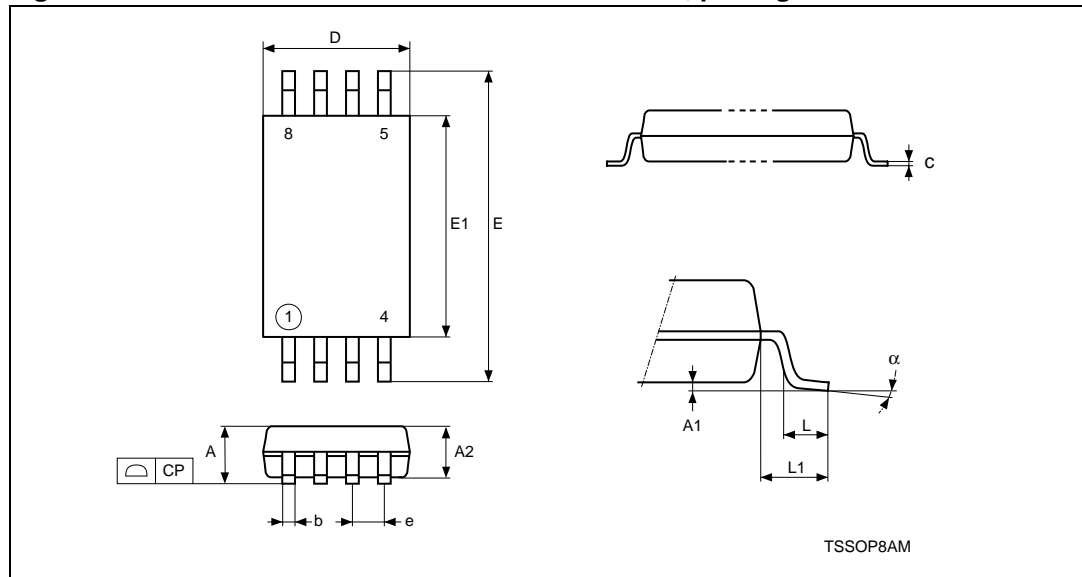

1. Drawing is not to scale.

Table 22. TSSOP8 – 8 lead thin shrink small outline, package mechanical data

Symbol	millimeters			inches ⁽¹⁾		
	Typ	Min	Max	Typ	Min	Max
A			1.200			0.0472
A1		0.050	0.150		0.0020	0.0059
A2	1.000	0.800	1.050	0.0394	0.0315	0.0413
b		0.190	0.300		0.0075	0.0118
c		0.090	0.200		0.0035	0.0079
CP			0.100			0.0039
D	3.000	2.900	3.100	0.1181	0.1142	0.1220
e	0.650	–	–	0.0256	–	–
E	6.400	6.200	6.600	0.2520	0.2441	0.2598
E1	4.400	4.300	4.500	0.1732	0.1693	0.1772
L	0.600	0.450	0.750	0.0236	0.0177	0.0295
L1	1.000			0.0394		
α		0°	8°		0°	8°
N		8			8	

1. Values in inches are converted from mm and rounded to 4 decimal digits.

11 Part numbering

Table 23. Ordering information scheme

Example:	M95256	-	W	MN	6	T	P	/A
Device type	<div style="border-left: 1px solid black; border-right: 1px solid black; border-bottom: 1px solid black; padding: 5px;"> <p>M95 = SPI serial access EEPROM</p> <p>256 = 256 Kbit (32768 x 8)</p> <p>blank = $V_{CC} = 4.5$ to 5.5 V W = $V_{CC} = 2.5$ to 5.5 V R = $V_{CC} = 1.8$ to 5.5 V</p> <p>MN = SO8 (150 mils width) MW = SO8 (200 mils width) DW = TSSOP8 (169 mils width)</p> <p>6 = Industrial temperature range, -40 to 85 °C. Device tested with standard test flow 3 = Device tested with High Reliability Certified Flow⁽¹⁾ Automotive temperature range (-40 to 125 °C)</p> <p>blank = Standard packing T = Tape and reel packing</p> <p>P or G = ECOPACK® (RoHs compliant)</p> <p>A = F8L⁽²⁾</p> </div>							
Device function								
Operating voltage								
Package								
Device grade								
Option								
Plating technology								
Process								

1. ST strongly recommends the use of the Automotive Grade devices for use in an automotive environment. The High Reliability Certified Flow (HRCF) is described in the quality note QNEE9801. Please ask your nearest ST sales office for a copy.
2. Used only for device grade 3.

For a list of available options (speed, package, etc.) or for further information on any aspect of this device, please contact your nearest ST Sales Office.

The category of second-level interconnect is marked on the package and on the inner box label, in compliance with JEDEC Standard JESD97. The maximum ratings related to soldering conditions are also marked on the inner box label.

Table 24. Available M95256x products (package, voltage range, temperature grade)

Package	M95256 (4.5 V to 5.5 V)	M95256-W (2.5 V to 5.5 V)	M95256-R (1.8 V to 5.5 V)
SO8N (MN)	Range 3	Range 6, Range 3	Range 6
SO8W (MW)	-	Range 6	-
TSSOP (DW)	-	Range 6	Range 6

12 Revision history

Table 25. Document revision history

Date	Revision	Changes
17-Nov-1999	2.1	New -V voltage range added (including the tables for DC characteristics, AC characteristics, and ordering information).
07-Feb-2000	2.2	New -V voltage range extended to M95256 (including AC characteristics, and ordering information).
22-Feb-2000	2.3	tCLCH and tCHCL, for the M95xxx-V, changed from 1 μ s to 100ns
15-Mar-2000	2.4	-V voltage range changed to 2.7-3.6V
29-Jan-2001	2.5	Lead Soldering Temperature in the Absolute Maximum Ratings table amended Illustrations and Package Mechanical data updated
12-Jun-2001	2.6	Correction to header of Table 12B TSSOP14 Illustrations and Package Mechanical data updated Document promoted from Preliminary Data to Full Data Sheet
08-Feb-2002	2.7	Announcement made of planned upgrade to 10 MHz clock for the 5V, -40 to 85°C, range.
09-Aug-2002	2.8	M95128 split off to its own datasheet. Data added for new and forthcoming products, including availability of the SO8 narrow package.
24-Feb-2003	2.9	Omission of SO8 narrow package mechanical data remedied
26-Jun-2003	2.10	-V voltage range removed
21-Nov-2003	3.0	Table of contents, and Pb-free options added. -S voltage range extended to -R. $V_{IL}(\text{min})$ improved to -0.45V
17-Mar-2004	4.0	Absolute Maximum Ratings for $V_{IO}(\text{min})$ and $V_{CC}(\text{min})$ changed. Soldering temperature information clarified for RoHS compliant devices. Device grade information clarified
21-Oct-2004	5.0	M95128 datasheet merged back in. Product List summary table added. AEC-Q100-002 compliance. Device Grade information clarified. tHHQX corrected to tHHQV. 10MHz product becomes standard

Table 25. Document revision history (continued)

Date	Revision	Changes
13-Apr-2006	6	<p>M95128 part numbers removed from document. PDIP8 package removed. <i>ECC (error correction code) and Write cycling</i> paragraph added. <i>Section 3.8: Supply voltage (VCC)</i> added and information removed below <i>Section 4: Operating features</i>.</p> <p>Power up state removed below <i>Section 6: Delivery state</i>. <i>Figure 13: SPI modes supported</i> modified and <i>Note 2</i> added. <i>Note 1</i> added to <i>Table 7</i>.</p> <p>I_{CC1} specified over the whole V_{CC} range and I_{CC0} added in <i>Table 13</i>, <i>Table 14</i> and <i>Table 15</i>. I_{CC} specified over the whole V_{CC} range in <i>Table 13</i>. <i>Table 17: AC Characteristics (M95256, Device Grade 6)</i> added.</p> <p>t_{CHHL} and t_{CHHH} replaced by t_{CLHL} and t_{CLHH}, respectively. <i>Figure 16: Hold timing</i> modified. <i>Process</i> added to <i>Table 23: Ordering information scheme</i>. <i>Note 1</i> added to <i>Table 23</i>.</p> <p><i>Note 1</i> removed from <i>Table 19: AC characteristics (M95256-R)</i>.</p> <p>T_A added to <i>Table 6: Absolute maximum ratings</i>.</p> <p>Order of sections modified.</p>
15-Oct-2007	7	<p>M95256 with device grade 6 temperature range removed.</p> <p><i>Section 3.7: VSS ground</i> added, <i>Section 3.8: Supply voltage (VCC)</i> modified. Small text changes.</p> <p><i>Section 5.4: Write Status Register (WRSR)</i>, <i>Section 5.5: Read from Memory Array (READ)</i> and <i>Section 5.6.1: ECC (error correction code) and Write cycling</i> updated.</p> <p><i>Note 2</i> below <i>Figure 12: Bus master and memory devices on the SPI bus</i> removed, replaced by explanatory paragraph.</p> <p>T_{LEAD} added to <i>Table 6: Absolute maximum ratings</i>.</p> <p>Test conditions modified for I_{CC0} and I_{CC1}, and V_{IH} min modified in <i>Table 16: AC characteristics (M95256, device grade 3)</i>.</p> <p>t_W modified and "preliminary data" note removed in <i>Table 19: AC characteristics (M95256-R)</i>.</p> <p>Blank option removed below Plating technology, process A modified and process V removed in <i>Table 23: Ordering information scheme</i>.</p> <p><i>Table 24: Available M95256x products (package, voltage range, temperature grade)</i> added.</p> <p>SO8N and SO8W package specifications updated (see <i>Section 10: Package mechanical</i>). Package mechanical data: inches calculated from mm and rounded to 3 decimal digits.</p>

Please Read Carefully:

Information in this document is provided solely in connection with ST products. STMicroelectronics NV and its subsidiaries ("ST") reserve the right to make changes, corrections, modifications or improvements, to this document, and the products and services described herein at any time, without notice.

All ST products are sold pursuant to ST's terms and conditions of sale.

Purchasers are solely responsible for the choice, selection and use of the ST products and services described herein, and ST assumes no liability whatsoever relating to the choice, selection or use of the ST products and services described herein.

No license, express or implied, by estoppel or otherwise, to any intellectual property rights is granted under this document. If any part of this document refers to any third party products or services it shall not be deemed a license grant by ST for the use of such third party products or services, or any intellectual property contained therein or considered as a warranty covering the use in any manner whatsoever of such third party products or services or any intellectual property contained therein.

UNLESS OTHERWISE SET FORTH IN ST'S TERMS AND CONDITIONS OF SALE ST DISCLAIMS ANY EXPRESS OR IMPLIED WARRANTY WITH RESPECT TO THE USE AND/OR SALE OF ST PRODUCTS INCLUDING WITHOUT LIMITATION IMPLIED WARRANTIES OF MERCHANTABILITY, FITNESS FOR A PARTICULAR PURPOSE (AND THEIR EQUIVALENTS UNDER THE LAWS OF ANY JURISDICTION), OR INFRINGEMENT OF ANY PATENT, COPYRIGHT OR OTHER INTELLECTUAL PROPERTY RIGHT.

UNLESS EXPRESSLY APPROVED IN WRITING BY AN AUTHORIZED ST REPRESENTATIVE, ST PRODUCTS ARE NOT RECOMMENDED, AUTHORIZED OR WARRANTED FOR USE IN MILITARY, AIR CRAFT, SPACE, LIFE SAVING, OR LIFE SUSTAINING APPLICATIONS, NOR IN PRODUCTS OR SYSTEMS WHERE FAILURE OR MALFUNCTION MAY RESULT IN PERSONAL INJURY, DEATH, OR SEVERE PROPERTY OR ENVIRONMENTAL DAMAGE. ST PRODUCTS WHICH ARE NOT SPECIFIED AS "AUTOMOTIVE GRADE" MAY ONLY BE USED IN AUTOMOTIVE APPLICATIONS AT USER'S OWN RISK.

Resale of ST products with provisions different from the statements and/or technical features set forth in this document shall immediately void any warranty granted by ST for the ST product or service described herein and shall not create or extend in any manner whatsoever, any liability of ST.

ST and the ST logo are trademarks or registered trademarks of ST in various countries.

Information in this document supersedes and replaces all information previously supplied.

The ST logo is a registered trademark of STMicroelectronics. All other names are the property of their respective owners.

© 2007 STMicroelectronics - All rights reserved

STMicroelectronics group of companies

Australia - Belgium - Brazil - Canada - China - Czech Republic - Finland - France - Germany - Hong Kong - India - Israel - Italy - Japan - Malaysia - Malta - Morocco - Singapore - Spain - Sweden - Switzerland - United Kingdom - United States of America

www.st.com

