

TC74VHCT573AF, TC74VHCT573AFW, TC74VHCT573AFT

OCTAL D-TYPE LATCH WITH 3-STATE OUTPUT

The TC74VHCT573A is an advanced high speed CMOS OCTAL LATCH with 3-STATE OUTPUT fabricated with silicon gate CMOS technology.

It achieves the high speed operation similar to equivalent Bipolar Schottky TTL while maintaining the CMOS low power dissipation.

This 8-bit D-type latch is controlled by a latch enable input (LE) and an output enable input (\overline{OE}).

When the \overline{OE} input is high, the eight outputs are in a high impedance state.

The input voltage are compatible with TTL output voltage. This device may be used as a level converter for interfacing 3.3V to 5V system.

Input protection and output circuit ensure that 0 to 5.5V can be applied to the input and output*1 pins without regard to the supply voltage. These structure prevents device destruction due to mismatched supply and input/output voltages such as battery back up, hot board insertion, etc.

*1: output in off-state

FEATURES:

- High Speed..... $t_{pd} = 7.7ns$ (typ.) at $V_{CC} = 5V$
- Low Power Dissipation..... $I_{CC} = 4\mu A$ (Max.) at $T_a = 25^\circ C$
- Compatible with TTL outputs.... $V_{IL} = 0.8V$ (Max.)
 $V_{IH} = 2.0V$ (Min.)
- Power Down Protection is provided on all inputs and outputs.
- Balanced Propagation Delays..... $t_{pLH} \approx t_{pHL}$
- Low Noise $V_{OLP} = 1.6V$ (Max.)
- Pin and Function Compatible with the 74 series (74AC / HC / F / ALS / LS etc.) 573 type.

(Note) The JEDEC SOP (FW) is not available in Japan.

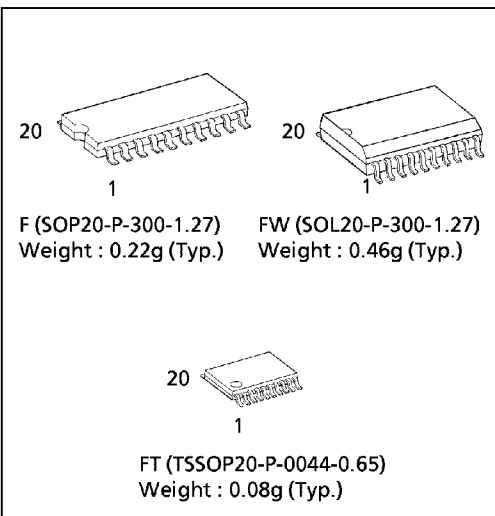

PIN ASSIGNMENT

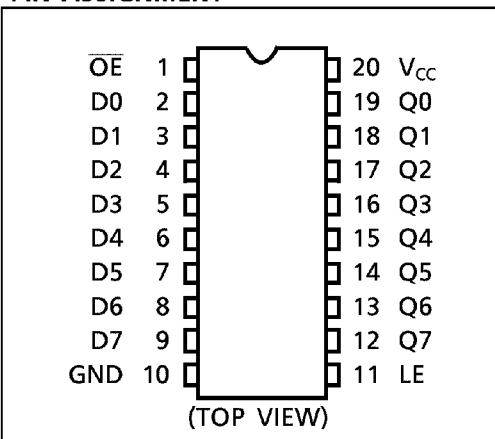

TRUTH TABLE

INPUTS			OUTPUT
\overline{OE}	LE	D	
H	X	X	Z
L	L	X	Q_n
L	H	L	L
L	H	H	H

X : Don't Care
Z : High Impedance
 Q_n : Q outputs are latched at the time when the LE input is taken to a low logic level.

IEC LOGIC SYMBOL

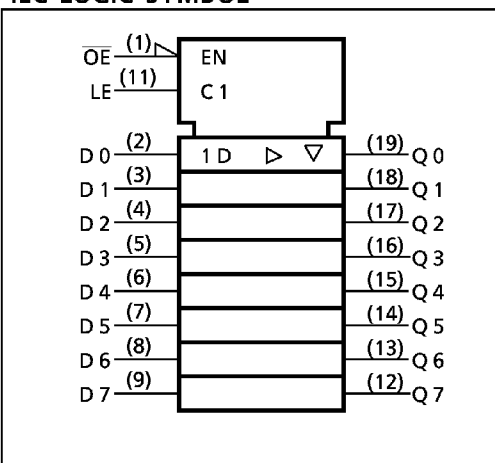

961001EBA2

● TOSHIBA is continually working to improve the quality and the reliability of its products. Nevertheless, semiconductor devices in general can malfunction or fail due to their inherent electrical sensitivity and vulnerability to physical stress. It is the responsibility of the buyer, when utilizing TOSHIBA products, to observe standards of safety, and to avoid situations in which a malfunction or failure of a TOSHIBA product could cause loss of human life, bodily injury or damage to property. In developing your designs, please ensure that TOSHIBA products are used within specified operating ranges as set forth in the most recent products specifications. Also, please keep in mind the precautions and conditions set forth in the TOSHIBA Semiconductor Reliability Handbook.

SYSTEM DIAGRAM

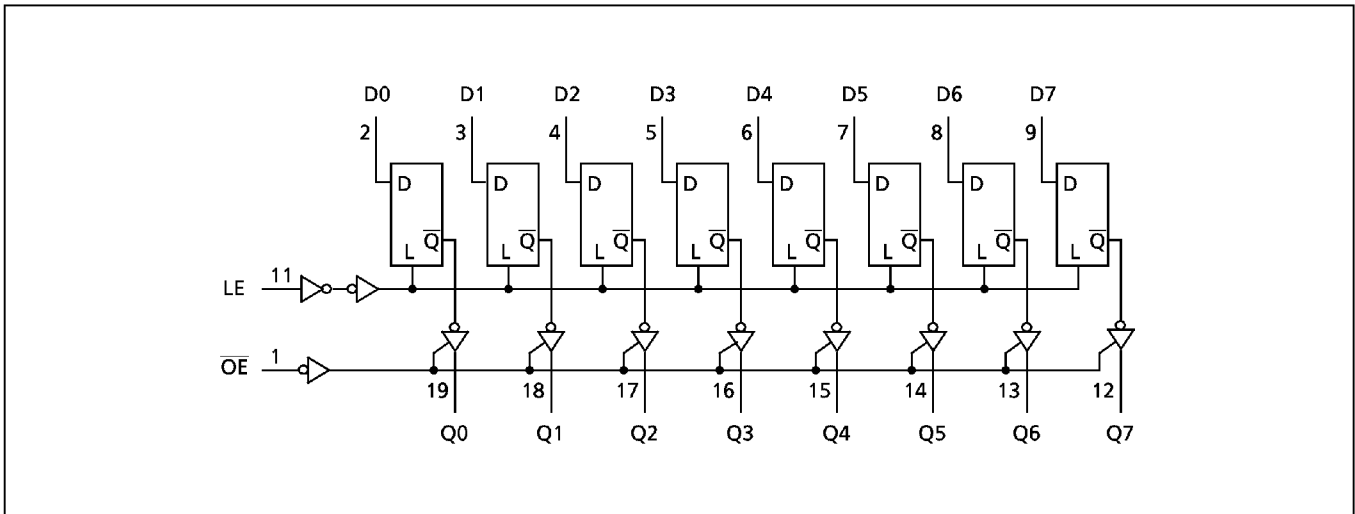

ABSOLUTE MAXIMUM RATINGS

PARAMETER	SYMBOL	VALUE	UNIT
Supply Voltage Range	V_{CC}	-0.5~7.0	V
DC Input Voltage	V_{IN}	-0.5~7.0	V
DC Output Voltage	V_{OUT}	-0.5~7.0 (Note 1)	V
		-0.5~ $V_{CC} + 0.5$ (Note 2)	
Input Diode Current	I_{IK}	-20	mA
Output Diode Current	I_{OK}	±20 (Note 3)	mA
DC Output Current	I_{OUT}	±25	mA
DC V_{CC} /Ground Current	I_{CC}	±75	mA
Power Dissipation	P_D	180	mW
Storage Temperature	T_{stg}	-65~150	°C

(Note 1) Output in Off-State

(Note 2) High or Low State. I_{OUT} absolute maximum rating must be observed.

(Note 3) $V_{OUT} < GND$, $V_{OUT} > V_{CC}$

RECOMMENDED OPERATING CONDITIONS

PARAMETER	SYMBOL	VALUE	UNIT
Supply Voltage	V_{CC}	4.5~5.5	V
Input Voltage	V_{IN}	0~5.5	V
Output Voltage	V_{OUT}	0~5.5 (Note 4)	V
		0~ V_{CC} (Note 5)	
Operating Temperature	T_{opr}	-40~85	°C
Input Rise and Fall Time	dt/dV	0~20	ns/V

(Note 4) Output in Off-State

(Note 5) High or Low State

961001EBA2'

- The products described in this document are subject to foreign exchange and foreign trade control laws.
- The information contained herein is presented only as a guide for the applications of our products. No responsibility is assumed by TOSHIBA CORPORATION for any infringements of intellectual property or other rights of the third parties which may result from its use. No license is granted by implication or otherwise under any intellectual property or other rights of TOSHIBA CORPORATION or others.
- The information contained herein is subject to change without notice.

DC ELECTRICAL CHARACTERISTICS

PARAMETER	SYMBOL	CONDITON		Ta = 25°C			Ta = -40~85°C		UNIT	
				V _{CC} (V)	MIN.	TYP.	MAX.	MIN.		MAX.
High - Level Input Voltage	V _{IH}			4.5~5.5	2.0	—	—	2.0	—	V
Low - Level Input Voltage	V _{IL}			4.5~5.5	—	—	0.8	—	0.8	V
High - Level Output Voltage	V _{OH}	V _{IN} = V _{IH} or V _{IL}	I _{OH} = -50μA	4.5	4.40	4.50	—	4.40	—	V
			I _{OH} = -8mA	4.5	3.94	—	—	3.80	—	
Low - Level Output Voltage	V _{OL}	V _{IN} = V _{IH} or V _{IL}	I _{OL} = 50μA	4.5	—	0.0	0.1	—	0.1	V
			I _{OL} = 8mA	4.5	—	—	0.36	—	0.44	
3 - State Output Off - State Current	I _{OZ}	V _{IN} = V _{IH} or V _{IL} V _{OUT} = V _{CC} or GND		5.5	—	—	±0.25	—	±2.50	μA
Input Leakage Current	I _{IN}	V _{IN} = 5.5V or GND		0~5.5	—	—	±0.1	—	±1.0	
Quiescent Supply Current	I _{CC}	V _{IN} = V _{CC} or GND		5.5	—	—	4.0	—	40.0	
	I _{CCT}	PER INPUT : V _{IN} = 3.4V OTHER INPUT : V _{CC} or GND		5.5	—	—	1.35	—	1.50	mA
Output Leakage Current	I _{OPD}	V _{OUT} = 5.5V		0	—	—	0.5	—	5.0	μA

TIMING REQUIREMENTS (Input t_r = t_f = 3ns)

PARAMETER	SYMBOL	TEST CONDITION		Ta = 25°C		Ta = -40~85°C	UNIT	
				V _{CC} (V)	TYP .	LIMIT		LIMIT
Minimum Pulse Width (LE)	t _W (H)			5.0 ± 0.5	—	6.5	8.5	ns
Minimum Set - up Time	t _s			5.0 ± 0.5	—	1.5	1.5	
Minimum Hold Time	t _h			5.0 ± 0.5	—	3.5	3.5	

AC ELECTRICAL CHARACTERISTICS (Input $t_r = t_f = 3\text{ns}$)

PARAMETER	SYMBOL	TEST CONDITION	Ta = 25°C			Ta = -40~85°C		UNIT	
			V _{CC} (V)	CL (pF)	MIN.	TYP.	MAX.		MIN.
Propagation Delay Time (LE-Q)	t_{pLH} t_{pHL}		5.0 ± 0.5	15	—	7.7	12.3	1.0	13.5
				50	—	8.5	13.3	1.0	14.5
Propagation Delay Time (D-Q)	t_{pLH} t_{pHL}		5.0 ± 0.5	15	—	5.1	8.5	1.0	9.5
				50	—	5.9	9.5	1.0	10.5
3-State Output Enable Time	t_{pZL} t_{pZH}	RL = 1kΩ	5.0 ± 0.5	15	—	6.3	10.9	1.0	12.5
				50	—	7.1	11.9	1.0	13.5
3-State Output Disable Time	t_{pLZ} t_{pHZ}	RL = 1kΩ	5.0 ± 0.5	50	—	8.8	11.2	1.0	12.0
Output to Output Skew	$t_{oS LH}$ $t_{oS HL}$	(Note 6)	5.0 ± 0.5	50	—	—	1.0	—	1.0
Input Capacitance	C _{IN}				—	4	10	—	10
Output Capacitance	C _{OUT}				—	6	—	—	—
Power Dissipation Capacitance	C _{PD}	(Note 7)			—	25	—	—	—

(Note 6) Parameter guaranteed by design. $t_{oS LH} = |t_{pLH m} - t_{pLH n}|$, $t_{oS HL} = |t_{pHL m} - t_{pHL n}|$

(Note 7) C_{PD} is defined as the value of the internal equivalent capacitance which is calculated from the operating current consumption without load.

Average operating current can be obtained by the equation:

$$I_{CC(opr.)} = C_{PD} \cdot V_{CC} \cdot f_{IN} + I_{CC} / 8 \text{ (per latch)}$$

And the total C_{PD} when n pcs. of Latch operate can be gained by the following equation:

$$C_{PD} \text{ (total)} = 14 + 11 \cdot n$$

NOISE CHARACTERISTICS (Input $t_r = t_f = 3\text{ns}$)

PARAMETER	SYMBOL	TEST CONDITION	Ta = 25°C		UNIT	
			V _{CC} (V)	TYP.		MAX.
Quiet Output Maximum Dynamic V _{OL}	V _{OLP}	C _L = 50pF	5.0	1.1 (1.2)	1.5 (1.6)	V
Quiet Output Minimum Dynamic V _{OL}	V _{OLV}	C _L = 50pF	5.0	-1.1 (-1.2)	-1.5 (-1.6)	V
Minimum High Level Dynamic Input Voltage	V _{IHD}	C _L = 50pF	5.0	—	2.0	V
Maximum Low Level Dynamic Input Voltage	V _{ILD}	C _L = 50pF	5.0	—	0.8	V

(Note) The value in () only applies to JEDEC SOP (FW) devices.

SOP 20PIN (200mil BODY) OUTLINE DRAWING (SOP20-P-300-1.27)

Unit in mm

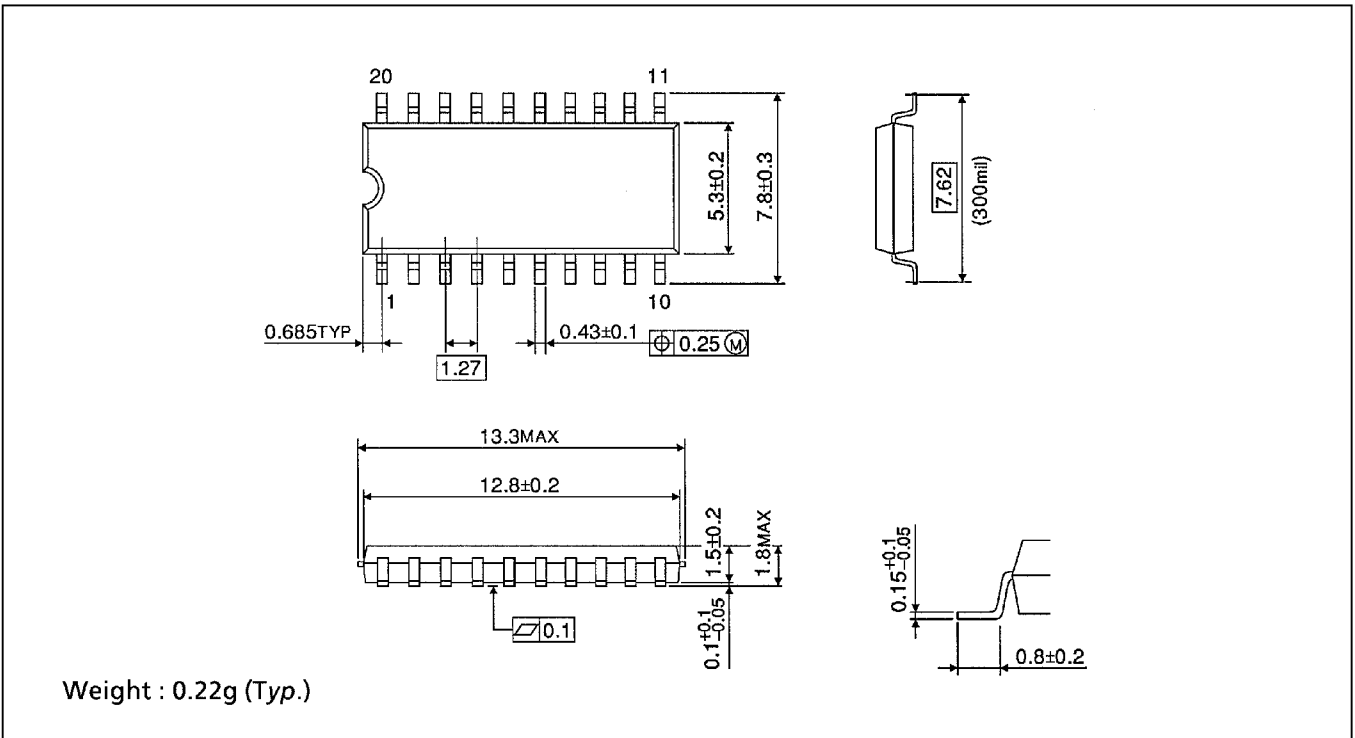

SOP 20PIN (300mil BODY) OUTLINE DRAWING (SOP20-P-300-1.27)

Unit in mm

(Note) This package is not available in Japan.

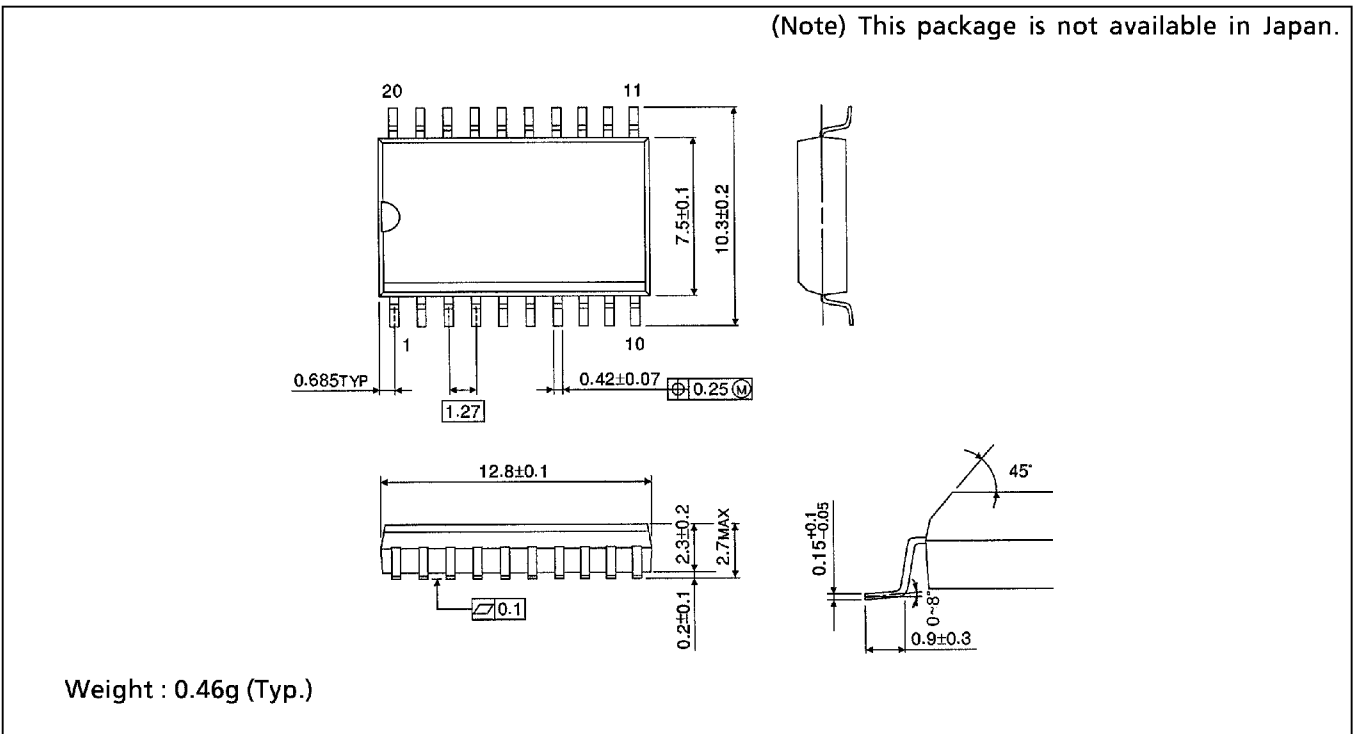

TSSOP 20PIN OUTLINE DRAWING (TSSOP20-P-0044-0.65)

Unit in mm

