

15 AMP. CONTROLLED AVALANCHE SILICON BRIDGE RECTIFIERS

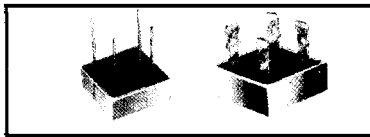

VOLTAGE RANGE
200 to 800 Volts
CURRENT
15 Amperes

FEATURES

- Controlled Avalanche Series with 250V, 450V, 650V, and 850V Minimum Avalanche Ratings
- 300 amperes surge capability
- High efficiency
- Electrically isolated metal case for maximum heat dissipation
- Weight: 1.1 ounce 31.6 grams (Terminal)
0.95 ounce 28.5 grams (Wire)
- Mounting: thru hole for # 8 screw

UL Recognized file = E95060

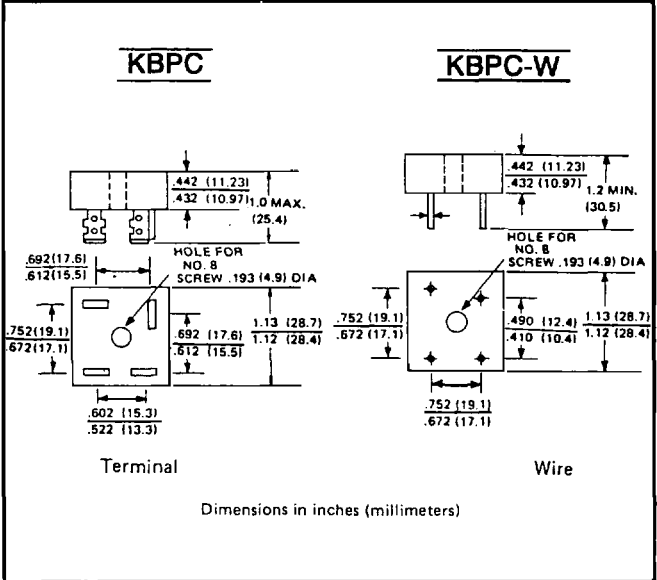

MAXIMUM RATINGS AND ELECTRICAL CHARACTERISTICS

Ratings at 25° C ambient temperature unless otherwise specified.
Single phase, half wave, 60Hz, resistive or inductive load,
For capacitive load, derate current by 20%.

		AKBPC 15-02	AKBPC 15-04	AKBPC 15-06	AKBPC 15-08	UNIT
		AKBPC 15-02W	AKBPC 15-04W	AKBPC 15-06W	AKBPC 15-08W	
Maximum Recurrent Peak Reverse Voltage	V_{RRM}	200	400	600	800	V
Maximum RMS Input Voltage	V_{RMS}	140	280	420	560	V
Minimum Avalanche Breakdown Voltage at 100 μ A		250	450	650	850	V
Maximum Avalanche Breakdown Voltage at 100 μ A		700	900	1100	1300	V
Maximum Average Forward Output Current @ $T_c = 55^\circ C$	$I_{(AV)}$	15				A
Peak Forward Surge Current, 8.3 ms Single Half Sine-wave superimposed on Rated Load (JEDEC Method)	I_{FSM}	300				A
Maximum Forward Voltage per Bridge Element at 7.5 A, DC	V_F	1.2				V
Maximum DC Reverse Current at Rated DC Blocking Voltage per Bridge Element @ $T_A = 25^\circ C$ @ $T_A = 100^\circ C$	I_R	10 1				μ A mA
I^2t Rating for fusing ($t < 8.3ms$)	I^2t	373				A ² S
Typical Thermal Resistance (Note. 2)	$R_{\theta JC}$	2.5				°C/W
Operating Temperature Range	T_J	-55 to + 125				°C
Storage Temperature Range	T_{STG}	-55 to + 150				°C

NOTE: 1. Mounted on a 11.8" x 0.06 in thick (300mm² X 1.5mm thick) Copper plate

FIG. 1. FORWARD DERATING CURVE

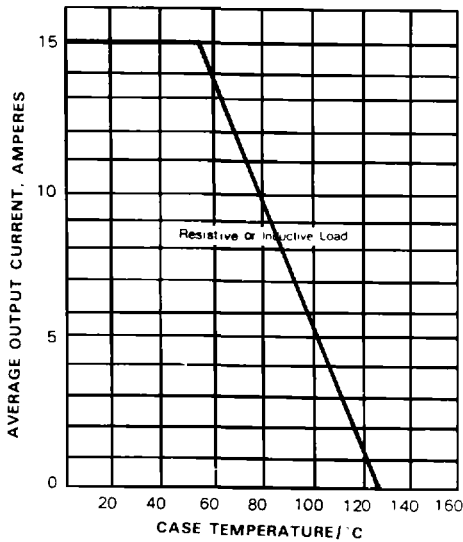

FIG. 2. PEAK FORWARD SURGE CURRENT

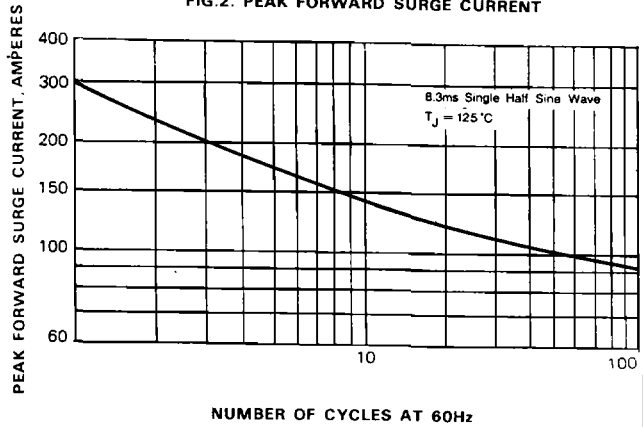

FIG. 3. TYPICAL FORWARD CHARACTERISTIC

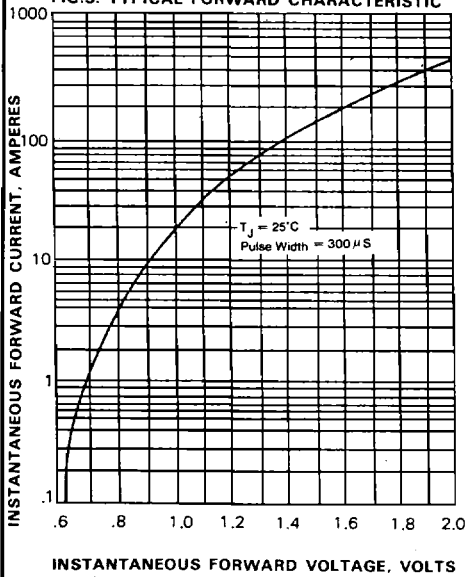

FIG. 4. TYPICAL REVERSE CHARACTERISTIC

