

9097250 TOSHIBA (DISCRETE/OPTO)

56C 07974 DT-33-09

SILICON NPN EPITAXIAL TYPE (PCT PROCESS)
(DARLINGTON POWER)

2SD1438

MICRO MOTOR DRIVE, HAMMER DRIVE APPLICATIONS.
SWITCHING APPLICATIONS.
POWER AMPLIFIER APPLICATIONS.

INDUSTRIAL APPLICATIONS
Unit in mm

FEATURES:

- High DC Current Gain
: $h_{FE}=2000(\text{Min.})$ ($V_{CE}=2V, I_C=1A$)
- Low Saturation Voltage
: $V_{CE}(\text{sat})=1.5V(\text{Max.})$ ($I_C=1A, I_B=1mA$)

MAXIMUM RATINGS ($T_a=25^\circ\text{C}$)

CHARACTERISTIC	SYMBOL	RATING	UNIT
Collector-Base Voltage	V_{CBO}	80	V
Collector-Emitter Voltage	V_{CEO}	80	V
Emitter-Base Voltage	V_{EBO}	8	V
Collector Current	I_C	2	A
Base Current	I_B	0.5	A
Collector Power Dissipation ($T_c=25^\circ\text{C}$)	P_C	15	W
Junction Temperature	T_j	150	$^\circ\text{C}$
Storage Temperature Range	T_{stg}	-55 ~ 150	$^\circ\text{C}$

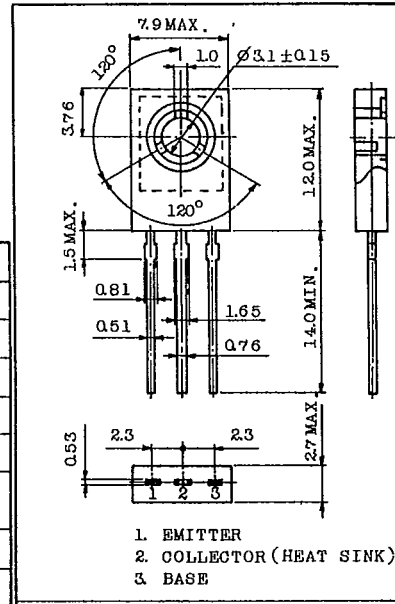

EQUIVALENT CIRCUIT

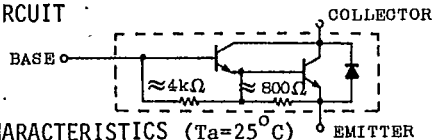

JEDEC	T0-126
EIAJ	-
TOSHIBA	2-8F1A
Mounting Kit No. AC46C	
Weight : 0.72g	

ELECTRICAL CHARACTERISTICS ($T_a=25^\circ\text{C}$)

CHARACTERISTIC	SYMBOL	TEST CONDITION	MIN.	TYP.	MAX.	UNIT	
Collector Cut-off Current	I_{CBO}	$V_{CB}=80V, I_E=0$	-	-	10	μA	
Emitter Cut-off Current	I_{EBO}	$V_{EB}=8V, I_C=0$	-	-	4	mA	
Collector-Emitter Breakdown Voltage	$V(BR)_{CEO}$	$I_C=10mA, I_B=0$	80	-	-	V	
DC Current Gain	h_{FE}	$V_{CE}=2V, I_C=1A$	2000	-	-		
Collector-Emitter Saturation Voltage	$V_{CE}(\text{sat})$	$I_C=1A, I_B=1mA$	-	-	1.5	V	
Base-Emitter Saturation Voltage	$V_{BE}(\text{sat})$	$I_C=1A, I_B=1mA$	-	-	2.0	V	
Transition Frequency	f_T	$V_{CE}=2V, I_C=0.5A$	-	100	-	MHz	
Collector Output Capacitance	C_{ob}	$V_{CB}=10V, I_E=0, f=1\text{MHz}$	-	20	-	pF	
Switching Time	Turn-on Time	t_{on}			-	0.4	-
	Storage Time	t_{stg}			-	4.0	-
	Fall Time	t_f			-	0.6	-

TOSHIBA CORPORATION

2SD1438

