

RN2414, 2415, 2416 RN2417, 2418

(RN2414)

SWITCHING, INVERTER CIRCUIT, INTERFACE CIRCUIT
AND DRIVER CIRCUIT APPLICATIONS.

- With Built-in Bias Resistors
- Simplify Circuit Design
- Reduce a Quantity of Parts and Manufacturing Process
- Complementary to RN1414~RN1418

EQUIVALENT CIRCUIT AND BIAS RESISTOR VALUES

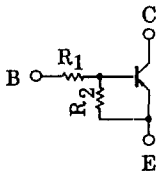

TYPE No.	R ₁ (kΩ)	R ₂ (kΩ)
RN2414	1	10
RN2415	2.2	10
RN2416	4.7	10
RN2417	10	4.7
RN2418	47	10

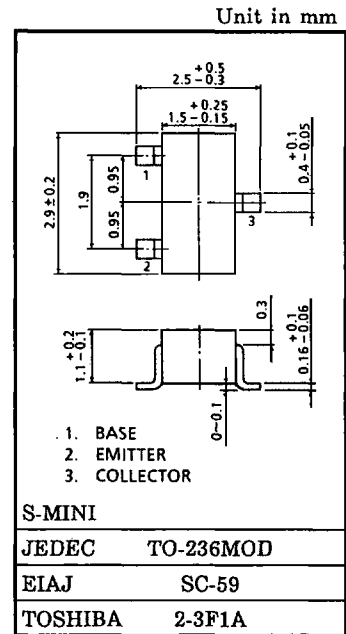

Weight : 0.012g

MAXIMUM RATINGS (Ta = 25°C)

CHARACTERISTIC		SYMBOL	RATING	UNIT
Collector-Base Voltage	RN2414~2418	V _{CBO}	-50	V
Collector-Emitter Voltage		V _{CEO}	-50	V
Emitter-Base Voltage	RN2414	V _{EBO}	-5	V
	RN2415		-6	
	RN2416		-7	
	RN2417		-15	
	RN2418		-25	
Collector Current	RN2414~2418	I _C	-100	mA
Collector Power Dissipation		P _C	200	mW
Junction Temperature		T _j	150	°C
Storage Temperature Range		T _{stg}	-55~150	°C

RN2414, 2415, 2416 RN2417, 2418

(RN2414)

ELECTRICAL CHARACTERISTICS (Ta = 25°C)

CHARACTERISTIC		SYMBOL	TEST CONDITION	MIN.	TYP.	MAX.	UNIT
Collector Cut-off Current	RN2414~2418	ICBO	V _{CB} = -50V, I _E = 0	—	—	-100	nA
	RN2414~2418	ICEO	V _{CE} = -50V, I _B = 0	—	—	-500	nA
Emitter Cut-off Current	RN2414	IEBO	V _{EB} = -5V, I _C = 0	-0.35	—	-0.65	mA
	RN2415			-0.37	—	-0.71	
	RN2416			-0.36	—	-0.68	
	RN2417			-0.78	—	-1.46	
	RN2418			-0.33	—	-0.63	
DC Current Gain	RN2414~16, 18	h _{FE}	V _{CE} = -5V, I _C = -10mA	50	—	—	
	RN2417			30	—	—	
Collector-Emitter Saturation Voltage	RN2414~2418	V _{CE(sat)}	I _C = -5mA, I _B = -0.25mA	—	-0.1	-0.3	V
Input Voltage (ON)	RN2414	V _{I(ON)}	V _{CE} = -0.2V, I _C = -5mA	-0.5	—	-2.0	V
	RN2415			-0.6	—	-2.5	
	RN2416			-0.7	—	-2.5	
	RN2417			-1.5	—	-3.5	
	RN2418			-2.5	—	-10.0	
Input Voltage (OFF)	RN2414	V _{I(OFF)}	V _{CE} = -5V, I _C = -0.1mA	-0.3	—	-0.9	V
	RN2415			-0.3	—	-1.0	
	RN2416			-0.3	—	-1.1	
	RN2417			-0.3	—	-3.0	
	RN2418			-0.5	—	-5.7	
Transition Frequency	RN2414~2418	f _T	V _{CE} = -10V, I _C = -5mA	—	200	—	MHz
Collector Output Capacitance	RN2414~2418	C _{ob}	V _{CB} = -10V, I _E = 0, f = 1MHz	—	3.0	6.0	pF
Input Resistor	RN2414	R ₁	—	0.7	1.0	1.3	kΩ
	RN2415			1.54	2.2	2.86	
	RN2416			3.29	4.7	6.11	
	RN2417			7.0	10.0	13.0	
	RN2418			32.9	47.0	61.1	
Resistor Ratio	RN2414	R ₁ / R ₂	—	—	0.1	—	
	RN2415			—	0.22	—	
	RN2416			—	0.47	—	
	RN2417			—	2.13	—	
	RN2418			—	4.7	—	

RN2414, 2415, 2416 RN2417, 2418

(RN2414)

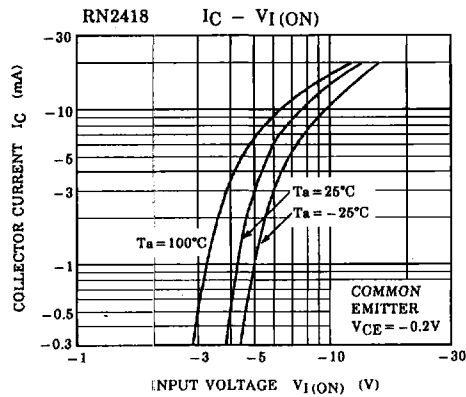
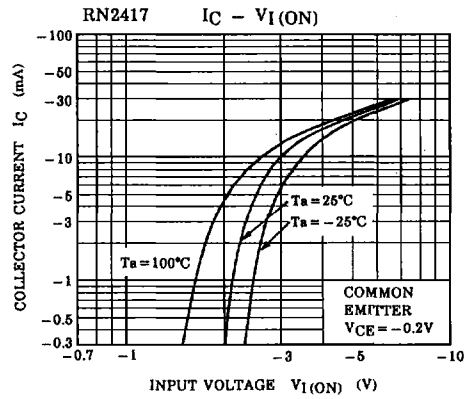
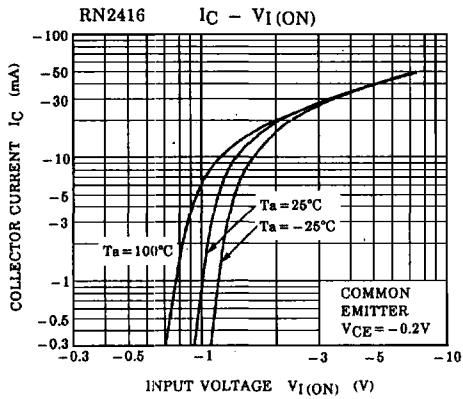
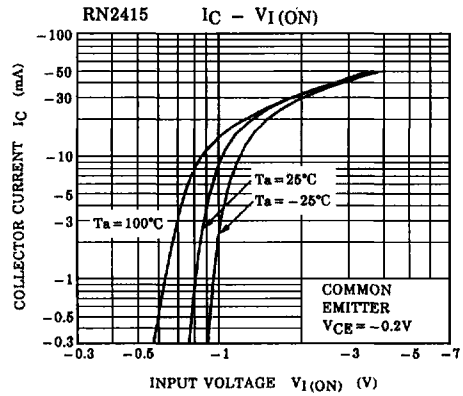
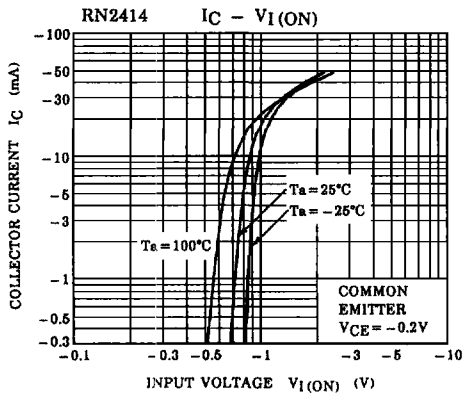

RN2414, 2415, 2416 RN2417, 2418

(RN2414)

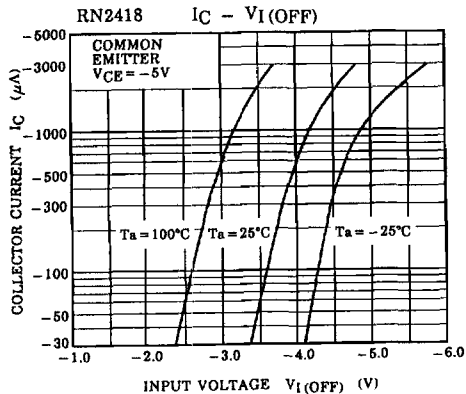
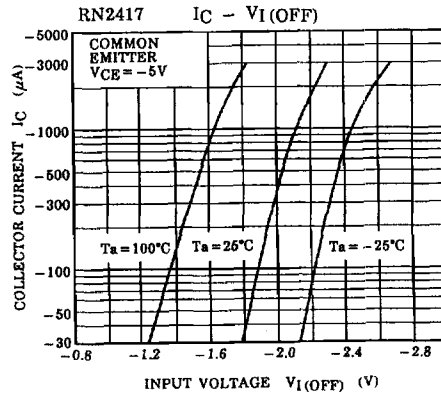
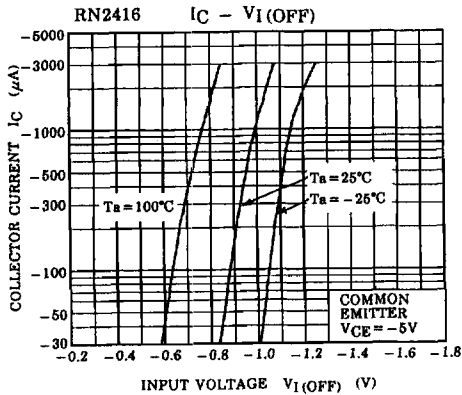
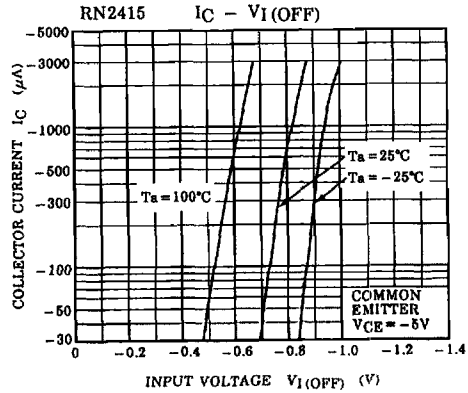
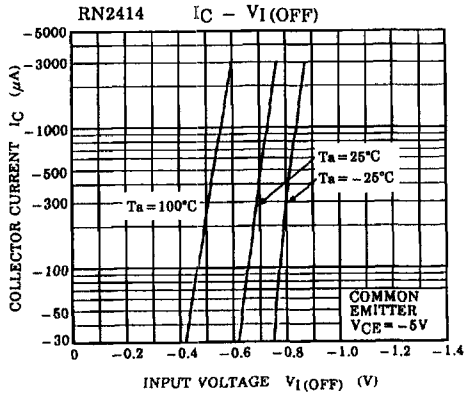

RN2414, 2415, 2416 RN2417, 2418

(RN2414)

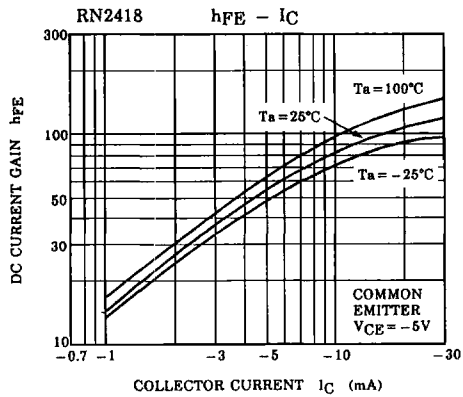
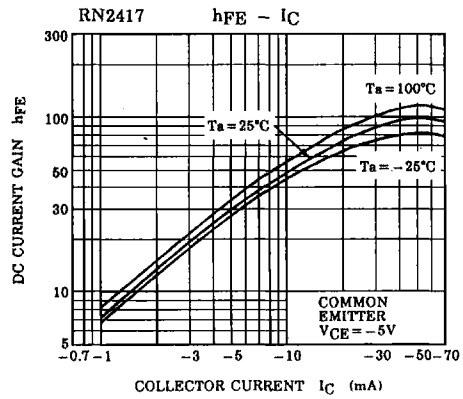
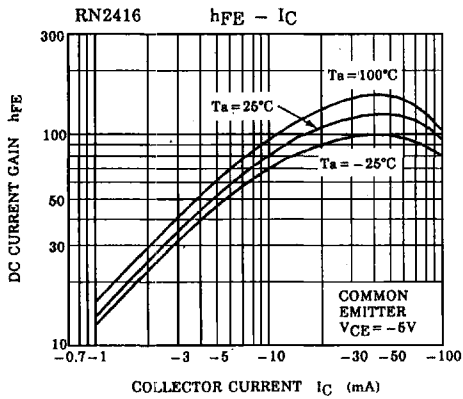
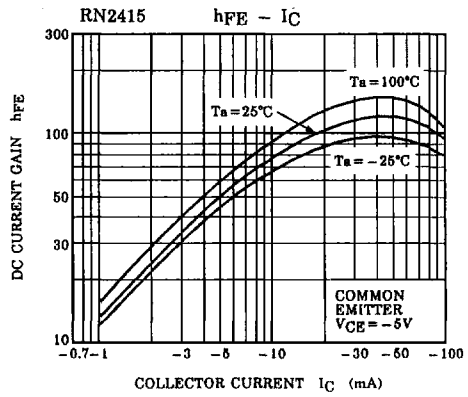
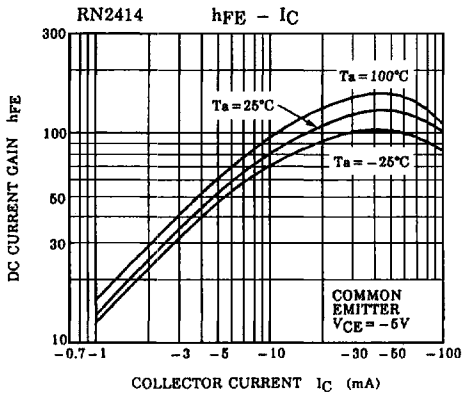

RN2414, 2415, 2416 RN2417, 2418

(RN2414)

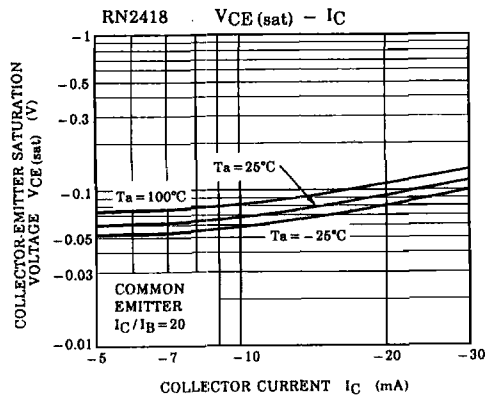
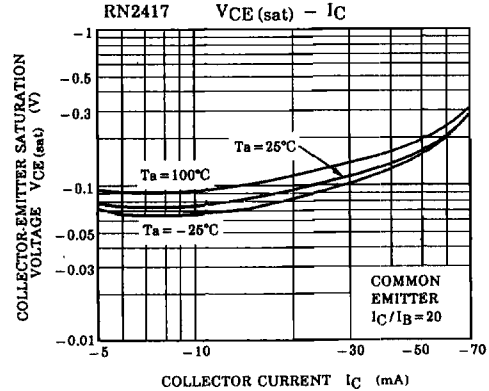
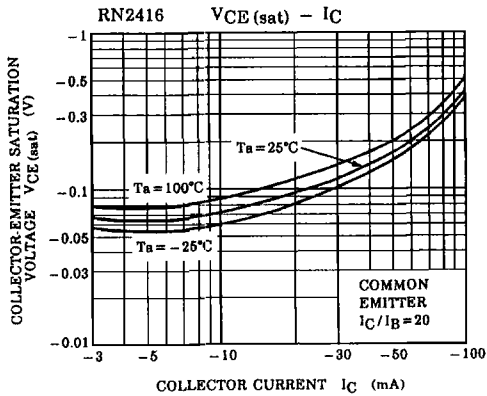
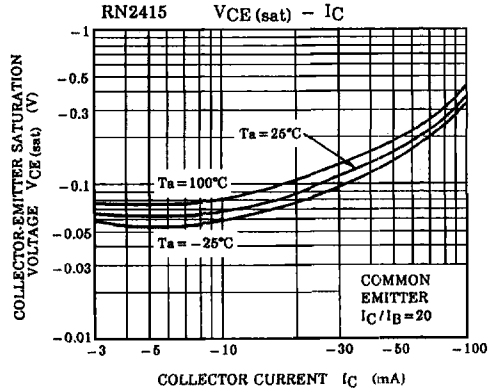
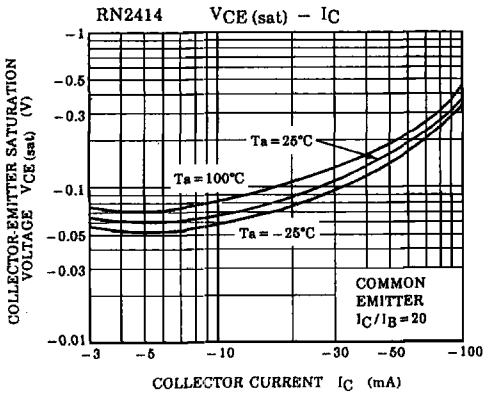

**RN2414, 2415, 2416
RN2417, 2418**

(RN2414)

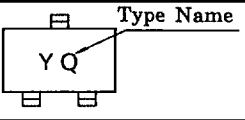
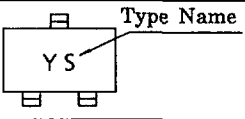
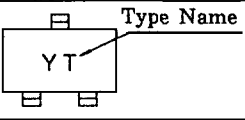
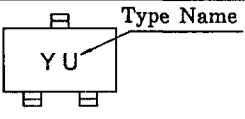
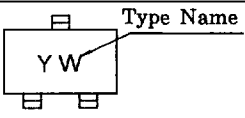
TYPE NAME	MARKING
RN2414	 A rectangular box with 'YQ' inside. A line points from the text 'Type Name' to the 'Q' in 'YQ'. There are small square symbols at the top and bottom of the box.
RN2415	 A rectangular box with 'YS' inside. A line points from the text 'Type Name' to the 'S' in 'YS'. There are small square symbols at the top and bottom of the box.
RN2416	 A rectangular box with 'YT' inside. A line points from the text 'Type Name' to the 'T' in 'YT'. There are small square symbols at the top and bottom of the box.
RN2417	 A rectangular box with 'YU' inside. A line points from the text 'Type Name' to the 'U' in 'YU'. There are small square symbols at the top and bottom of the box.
RN2418	 A rectangular box with 'YW' inside. A line points from the text 'Type Name' to the 'W' in 'YW'. There are small square symbols at the top and bottom of the box.